

## optris® CSlaser 2M

Two-wire infrared thermometer for temperature measurement of metals from 250°C to 1600°C



### FEATURES

- Accurate temperature measurements of metals, secondary metal processing and ceramic materials
- Temperature ranges from 250 °C to 1600 °C, measuring spots up from 0,5 mm and response times up from 10 ms
- Standard two-wire interface for reliable data transfer and easy integration into a PLC
- Innovative double-laser sighting for exact marking of measurement targets
- Fast sensor parameterisation and real-time measurement via USB
- Dependable in ambient temperatures up to 85°C without additional cooling

#### General specifications

Environmental rating	IP 65 (NEMA-4) front mountable at vacuum processes (up to 10 <sup>-3</sup> mbar)
Ambient temperature	-20°C to 85°C (50°C with laser ON)
Storage temperature	-40°C to 85°C
Relative humidity	10 - 95%, non condensing
Vibration	IEC 68-2-6: 3 G, 11-200 Hz, any axis
Shock	IEC 68-2-27: 50 G, 11 ms, any axis
Weight	600 g

#### Electrical specifications

Output / analog	4 - 20 mA
Loop resistance	max. 1000 Ω <sup>1)</sup>
Output / alarm	0 - 30 V / 500 mA (open-collector)
Output/ digital	uni-/ bidirectional, 9,6 kBaud, 0/3 V Pegel, USB optional
Cable length (connector version only)	3 m / 8 m / 15 m
Current draw (laser)	45 mA at 5 V 20 mA at 12 V 12 mA at 24 V
Power supply	5 - 28 V DC

#### Measurement specifications

Temperature range (scalable via software)	250°C to 800°C (2ML) 385°C to 1600°C (2MH)
Spectral range	1.6 μm
Optical resolution (90 % energy)	150:1 (2ML) 300:1 (2MH)
System accuracy (at T <sub>amb</sub> = 23 ± 5°C)	± (0.3 % of reading + 2 °C)
Repeatability (at T <sub>amb</sub> = 23 ± 5°C)	± (0.1 % of reading + 1 °C)
Temperature resolution	0.1 K
Response time (90% signal)	10 ms
Emissivity/ Gain (adjustable via sensor or software)	0.100 - 1.100
IR window correction (adjustable via software)	0.100 - 1.000
Signal processing (parameter adjustable via software)	peak hold, valley hold, average; extended hold function with threshold and hysteresis
Software	optris Compact Connect

<sup>1)</sup> in dependence on supply voltage

## Optical parameter

### Chart of SF optics

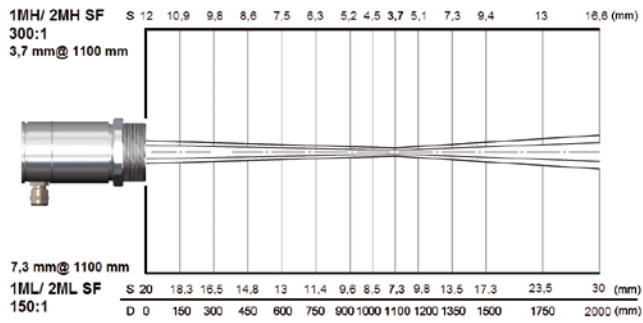

Further optics:

...CF2	0,5 mm @ 150 mm
...CF3	0,7 mm @ 200 mm
...CF4	1,5 mm @ 450 mm
...FF	12 mm @ 3600 mm

D:S = 300:1  
(2MH)

D:S = 150:1  
(2ML)

...CF2	1,0 mm @ 150 mm
...CF3	1,3 mm @ 200 mm
...CF4	3,0 mm @ 450 mm
...FF	24 mm @ 3600 mm

## Connections

### Analog mode of operation

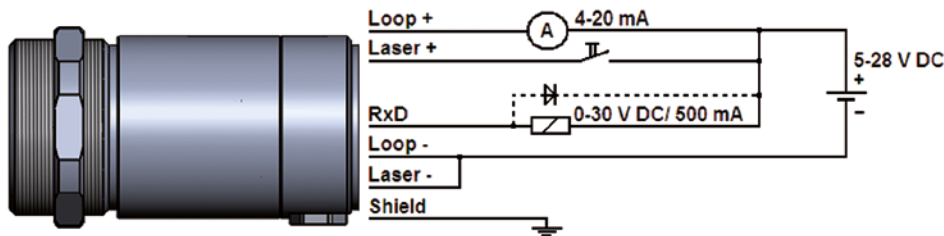

### Digital mode of operation

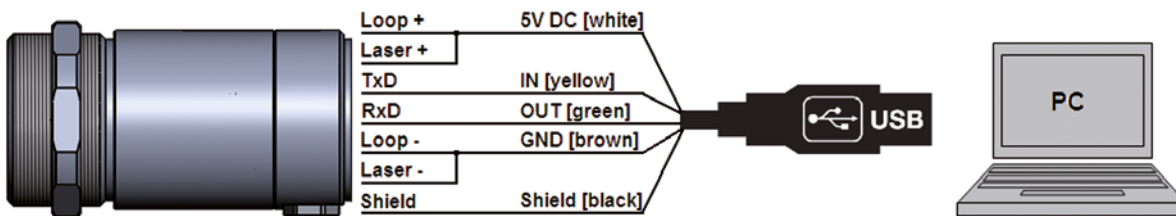

## Dimensions

### Dimensions CSLaser hs LT

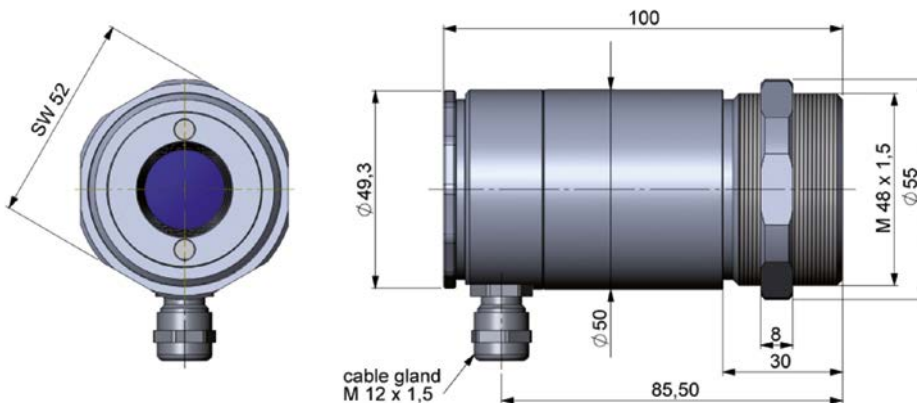

### Electrical connections / emissivity adjustment (sensor back side)

