

# Inductive distance measuring sensors

## IWRM 18Z8704/S14C

### dimension drawing

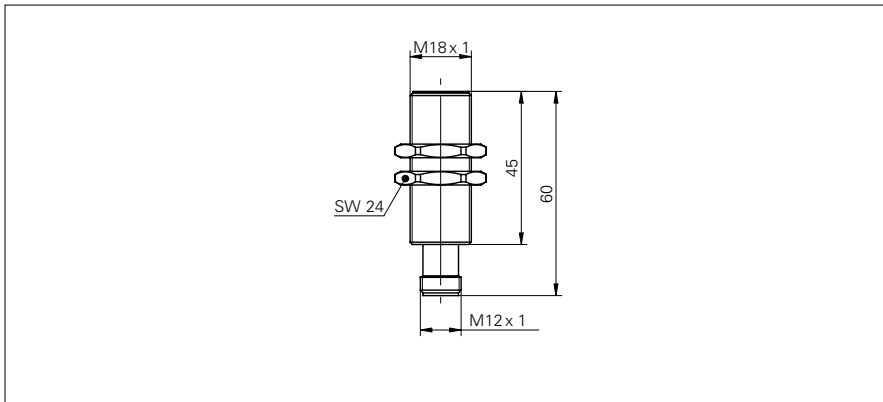

### general data

mounting type	quasi-flush
special type	2 adjust. switching points linearized
measuring distance Sd	0 ... 8 mm
resolution	< 0,01 mm (stat.) < 0,01 mm (dynam.)
repeat accuracy	< 0,015 mm
adjustment	external Teach-in
linearity error	± 32 µm
temperature drift	± 5 % (Full Scale)

### electrical data

response time (factory characteristic)	< 2 ms
response time (teach in characteristic)	< 3,1 ms
voltage supply range +Vs	15 ... 30 VDC
current consumption max. (no load)	20 mA
output circuit	voltage output / PNP
output signal	0 ... 10 VDC
load resistance	> 1000 Ohm
output current	< 10 mA (PNP)
voltage drop Vd	< 5 VDC (PNP)
short circuit protection	yes
reverse polarity protection	yes

### mechanical data

type	cylindrical threaded
housing material	brass nickel plated
dimension	18 mm
housing length	60 mm
connection types	connector M12

### ambient conditions

operating temperature	-10 ... +70 °C
protection class	IP 67

### photo



### connection diagram

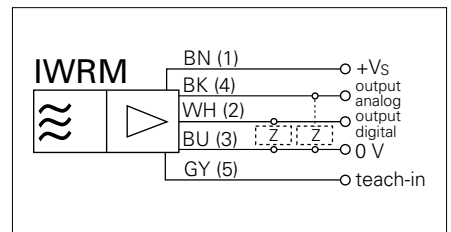

### installation drawing

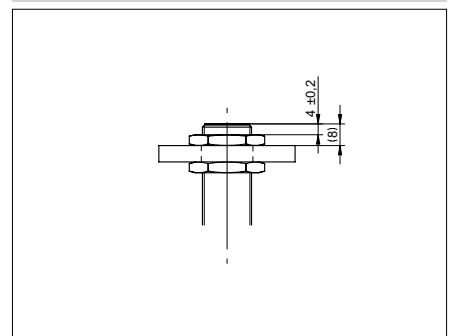

- external Teach-in
- integrated analog- and switching output
- linear analog output