

Distance sensors

OADM 13S7580/S35A

dimension drawing

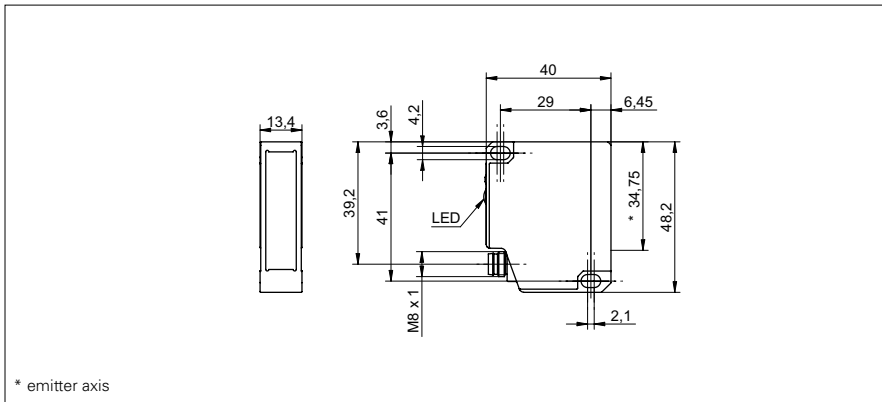

general data

measuring distance Sd	50 ... 550 mm
adjustment	no
power on indication	LED green
resolution	0,09 ... 1,15 mm
linearity error	± 0,3 ... ± 3,5 mm
light source	pulsed red laser diode
wave length	650 nm
laser class	2
beam type	line
beam width	2 mm
beam height	4 ... 13 mm
alarm indicator	LED red
temperature drift	< 0,07 % Sde/K

electrical data

response time / release time	< 2 ms
voltage supply range +Vs	12 ... 28 VDC
current consumption max. (no load)	80 mA
output circuit	RS 485
baud rate	38400, adjustable
short circuit protection	yes
reverse polarity protection	yes, Vs to GND

mechanical data

width / diameter	13,4 mm
height / length	48,2 mm
depth	40 mm
type	rectangular
housing material	aluminum
front (optics)	glass
connection types	connector M8 4 pin

photo



connection diagram

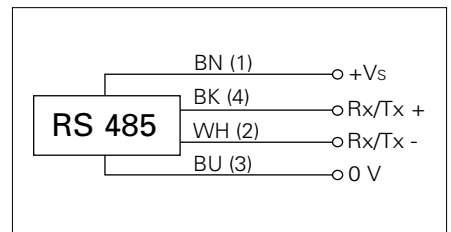

laser warning

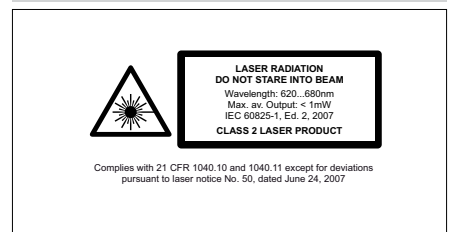

- For objects with a reflectivity < 10 % the response time/release time is increased automatically up to max. 5 ms.

Distance sensors**OADM 13S7580/S35A****ambient conditions**

ambient light immunity	< 100 kLux
operating temperature	0 ... +50 °C
protection class	IP 67