

Combination

Encoder with integrated programmable, digital speed switch

Through hollow shaft $\varnothing 20...50$ mm

512...2500 pulses per revolution

HOG 16 + DSL

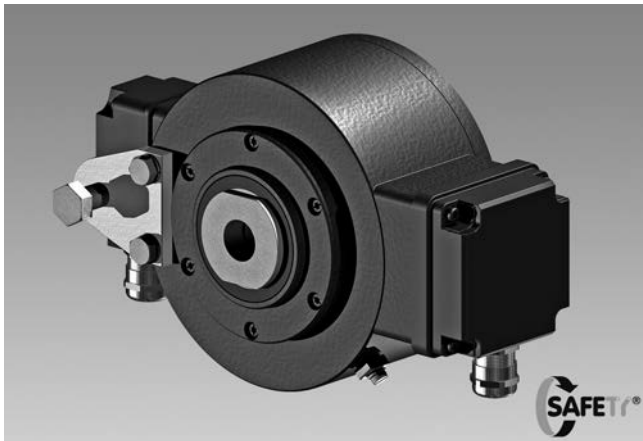

HOG 16 + DSL

Features

- Freely programmable on and off switching speed
- Programming via included software (RS485 interface)
- Logic level HTL or TTL
- DSL.R: 3 outputs speed controlled; DSL.E: 2 outputs speed controlled and 1 control output

Optional

- Relay module DS 93 R (DSL.R version only)
- Redundant sensing (option M)
- Hybrid bearing
- Earthing brushes

Technical data - electrical ratings

Consumption w/o load	≤ 200 mA
Sensing method	Optical

HOG 16 + DSL.E

Voltage supply	9...30 VDC
----------------	------------

HOG 16 + DSL.R

Voltage supply	15...30 VDC
----------------	-------------

Technical data - electrical ratings (encoder)

Pulses per revolution	512...2500
Phase shift	$90^\circ \pm 20^\circ$
Scan ratio	40...60 %
Reference signal	Zero pulse, width 90°
Output frequency	≤ 120 kHz
Output signals	K1, K2, K0 + inverted
Output stages	HTL TTL/RS422

Technical data - electrical ratings (speed switches)

Interface	RS485
Switching accuracy	± 2 % (or Digit)
Switching delay time	≤ 40 ms

HOG 16 + DSL.E

Switching outputs	2 outputs, speed control 1 control output
Output switching capacity	5...230 VAC/VDC; 5...250 mA

HOG 16 + DSL.R

Switching outputs	3 outputs, speed control
Output switching capacity	12 VDC; ≤ 40 mA

Technical data - mechanical design

Size (flange)	$\varnothing 158$ mm
Shaft type	$\varnothing 20...50$ mm (through hollow shaft)
Admitted shaft load	≤ 450 N axial ≤ 600 N radial
Protection DIN EN 60529	IP 66
Speed (n)	≤ 6000 rpm
Range of switching speed (ns)	Pulses = 512: $\pm 16...6000$ rpm Pulses = 1024: $\pm 8...6000$ rpm Pulses = 2048: $\pm 4...3500$ rpm Pulses = 2500: $\pm 3...2900$ rpm
Operating torque	≤ 15 Ncm
Rotor moment of inertia	4.9 kgcm ²
Materials	Housing: aluminium Shaft: stainless steel
Operating temperature	$-20...+85$ °C
Resistance	IEC 60068-2-6 Vibration 15 g, 10-2000 Hz IEC 60068-2-27 Shock 300 g, 6 ms
Connection	2x terminal box 3x terminal box (with option M)
Weight approx.	4 kg, 5 kg (with option M)
Interference immunity	EN 61000-6-2
Emitted interference	EN 61000-6-3
Approval	CE

Combination

Encoder with integrated programmable, digital speed switch
Through hollow shaft ø20...50 mm
512...2500 pulses per revolution

HOG 16 + DSL

Part number

Encoder with digital speed switch DSL.E

Encoder with digital speed switch DSL.R

HOG16							HOG16													
						DN							+							
													DSL.E							
													DSL.R							
							Shaft diameter 20H7 Through hollow shaft ø20 mm 25H7 Through hollow shaft ø25 mm 30H7 Through hollow shaft ø30 mm 50H7 Through hollow shaft ø50 mm							Shaft type Standard ball bearings C With hybrid bearings						
							Incremental output I Output circuit HTL with inverted signals R Output circuit TTL with inverted signals							Shaft diameter 20H7 Through hollow shaft ø20 mm 25H7 Through hollow shaft ø25 mm 30H7 Through hollow shaft ø30 mm 50H7 Through hollow shaft ø50 mm						
							Pulse number - see table							Incremental output I Output circuit HTL with inverted signals R Output circuit TTL with inverted signals						
							Output signals DN K1, K2, K0 + inverted							Pulse number - see table						
							Redundant sensing Without redundant sensing M With redundant sensing							Output signals DN K1, K2, K0 + inverted						
							Shaft type Standard ball bearings C With hybrid bearings							Redundant sensing Without redundant sensing M With redundant sensing						

Pulse number

512	1024	2048	2500
-----	------	------	------

Accessories

Adapter USB → RS485

Connectors and cables

HEK 8 Sensor cable for encoders

Mounting accessories

DMS 12 Torque arm size M12

11069336 Mounting kit for torque arm size M12 and an earthing strap

Diagnostic accessories

HENQ 1100 Analyzer for encoders

Relay module for HOG 16 + DSL.R

DS 93 R Relay modul

Combination

Encoder with integrated programmable, digital speed switch

Through hollow shaft $\varnothing 20...50$ mm

512...2500 pulses per revolution

HOG 16 + DSL

Output signals

At positive rotating direction

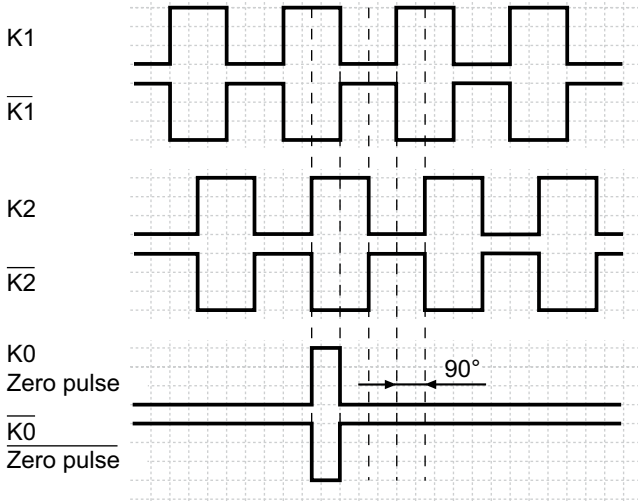

Terminal assignment

View A - Connecting terminal in terminal box

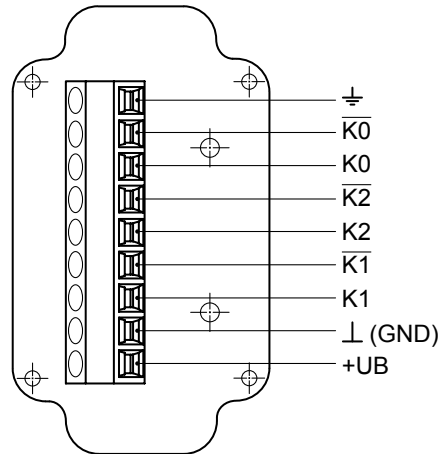

Terminal significance

Speed switch version DSL.R

R1*	Transistor switching output 1, individually adjustable switching speed, High (12 V), Low (0 V), max. 20 mA
R2*	Transistor switching output 2, individually adjustable switching speed, High (12 V), Low (0 V), max. 20 mA
R3*	Transistor switching output 3, individually adjustable switching speed, High (12 V), Low (0 V), max. 20 mA
GND*	Ground connection
RS 485	Interface for PC or Laptop (adapter required). Programming of the DSL via the included software.

* Connection to relay module, for example DS 93 R (accessory)

Speed switch version DSL.E

R1 (A+B)	Electronic relay output 1, individually adjustable switching speed, 5 ... 230 V AC/DC
R2 (A+B)	Electronic relay output 2, individually adjustable switching speed, 5 ... 230 V AC/DC
C1 (A+B)	Electronic relay output as a control output, 5 ... 250 mA
RS 485	Interface for PC or Laptop (adapter required). Programming of the DSL via the included software.

View B - Connecting terminal speed switch Version DSL.R

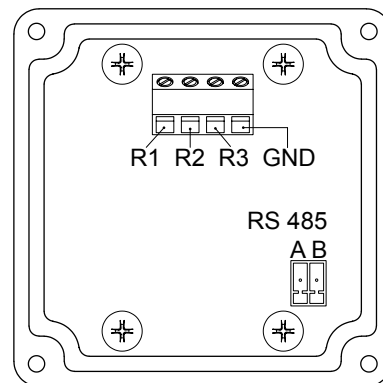

View B - Connecting terminal speed switch Version DSL.E

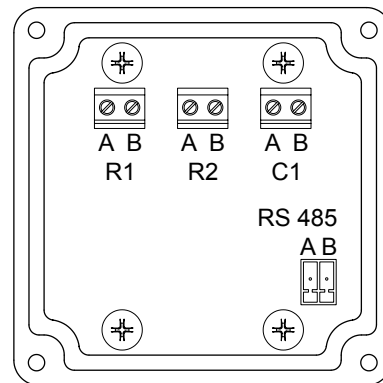

Combination

Encoder with integrated programmable, digital speed switch
Through hollow shaft $\varnothing 20...50$ mm
512...2500 pulses per revolution

HOG 16 + DSL

Block circuit diagram

Version with DSL.E

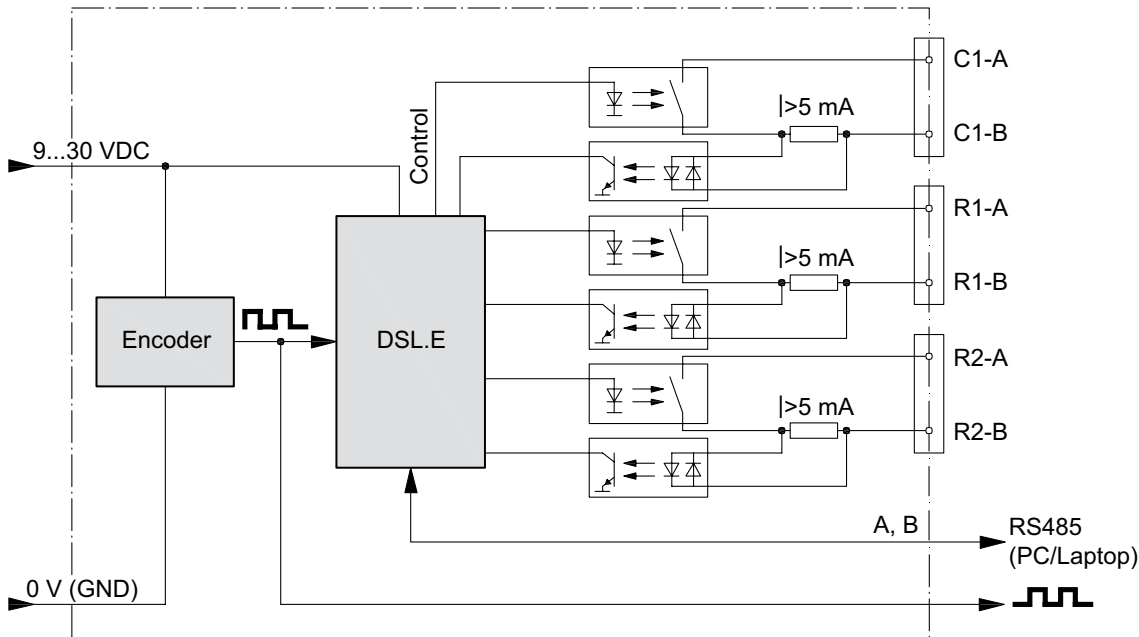

Version with DSL.R

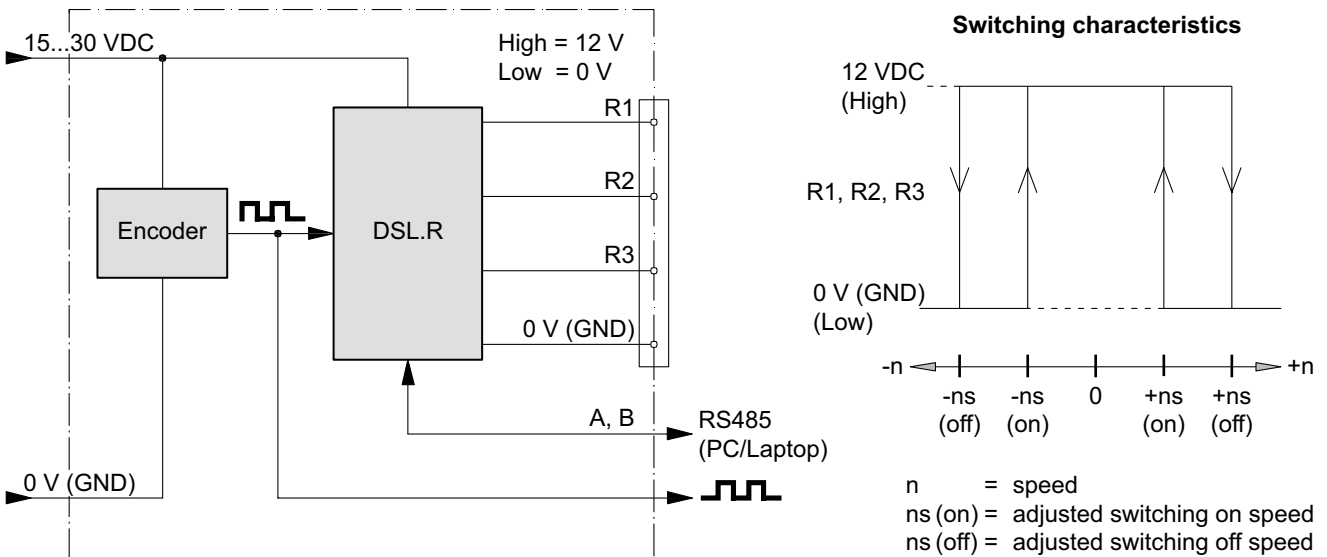

Combination

Encoder with integrated programmable, digital speed switch

Through hollow shaft $\varnothing 20...50$ mm

512...2500 pulses per revolution

HOG 16 + DSL

Dimensions

HOG 16 + DSL - Version with insert nut

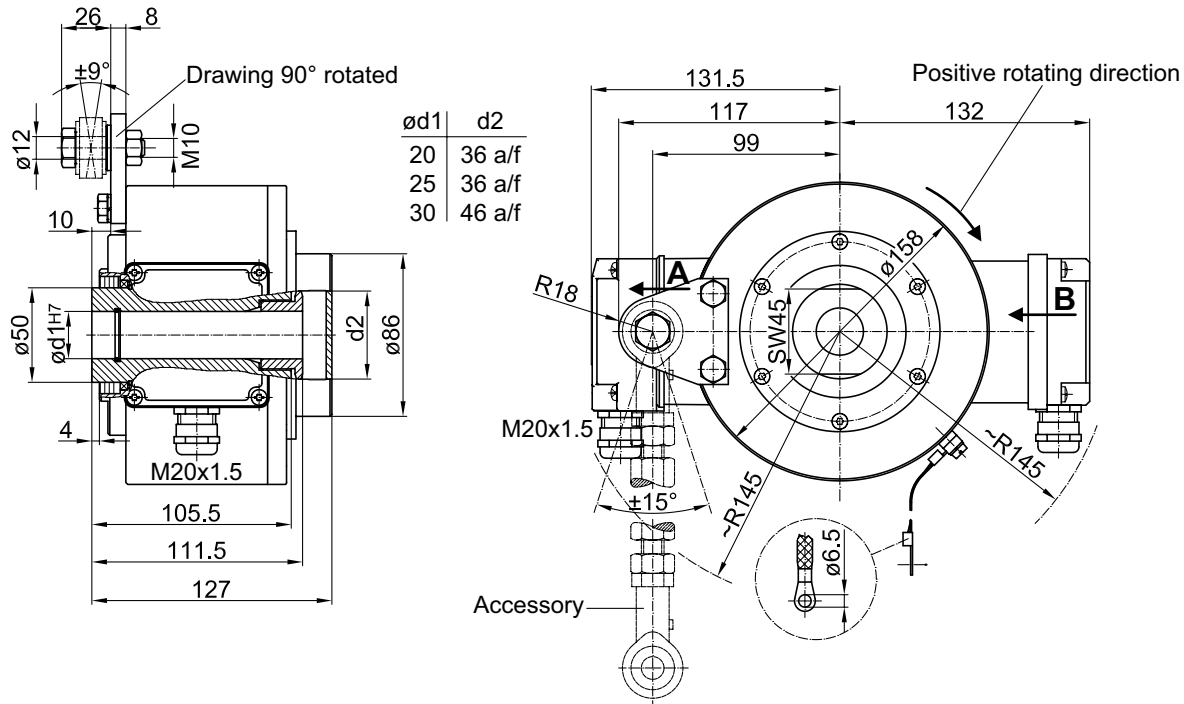

HOG 16 M + DSL - Version with clamping ring

