

Combination

Tachogenerator with integrated electronic speed switch

Solid shaft with EURO flange B10

TDP 0,2 + ESL



TDP 0,2 + ESL

Features

- Low response time
- Open circuit voltage 10...150 mV per rpm
- High signal quality due to patented LongLife technology
- Recognition of sense of rotation possible via control
- Electronic speed monitoring
- Circuit breaker with up to three selectable threshold speeds

Optional

- Housing foot (B3)

Technical data - electrical ratings

Interference immunity	EN 61000-6-2
Emitted interference	EN 61000-6-3

Technical data - electrical ratings (tachogenerator)

Reversal tolerance	≤0.1 %
Linearity tolerance	≤0.15 %
Temperature coefficient	±0.05 %/K (open-circuit)
Isolation class	B
Calibration tolerance	±1 %
Climatic test	Humid heat, constant (IEC 60068-2-3, Ca)
Performance	12 W (speed ≥3000 rpm)
Armature-circuit time-constant	<75 μs
Open-circuit voltage	10...150 mV per rpm

Technical data - electrical ratings (speed switches)

Switching accuracy	±4 % (≤1500 rpm) ±2 % (>1500 rpm)
Switching hysteresis	=30 % of switching speed
Switching delay time	≤40 ms

TDP 0,2 + ESL 90

Switching outputs	1 output, speed control
Output switching capacity	≤6 A / 250 VAC ≤1 A / 48 VDC
Minimum switching current	100 mA

TDP 0,2 + ESL 93

Voltage supply	12 VDC ±10 %
Consumption w/o load	≤5 mA
Switching outputs	3 outputs, speed control
Current each output	40 mA (DC)

Technical data - mechanical design

Size (flange)	ø115 mm
Shaft type	ø11 mm solid shaft
Admitted shaft load	≤60 N axial ≤80 N radial
Flange	EURO flange B10
Protection DIN EN 60529	IP 55
Torque	1.5 Ncm
Rotor moment of inertia	1.4 kgcm ²
Materials	Housing: aluminium die-cast Shaft: stainless steel
Operating temperature	-20...+85 °C
Resistance	IEC 60068-2-6 Vibration 5 g, 10-2000 Hz IEC 60068-2-27 Shock 150 g, 1 ms
Connection	2x terminal box
Weight approx.	3.2 kg
Approval	CE

TDP 0,2 + ESL 90

Speed (n)	≤6000 rpm
Range of switching speed (ns)	650...6000 rpm

TDP 0,2 + ESL 93

Speed (n)	≤5000 rpm
Range of switching speed (ns)	200...5000 rpm

Combination

Tachogenerator with integrated electronic speed switch

Solid shaft with EURO flange B10

TDP 0,2 + ESL

Part number

Tachogenerator with speed switch ESL 90

TDP0,2 LT- **55 + ESL90** ...

- Switching speed (ns)
 - ... 650...6000 rpm
- Mounting type
 - B10 EURO flange B10
 - B3 Housing foot
- Open-circuit voltage
 - 6 10 mV per rpm
 - 7 20 mV per rpm
 - 10 30 mV per rpm
 - 5 40 mV per rpm
 - 4 60 mV per rpm
 - 3 100 mV per rpm
 - 1 150 mV per rpm

* Please specify the exact switching speed in addition to the part number (factory setted threshold).

Data according to type

Type	Open-circuit voltage	Minimum load required depending on speed range [rpm]			Maximum operating speed	Armature resistance	Armature inductance
		0-3000	0-6000	0-n _{max}			
	U ₀ [mV/rpm]	R _L [kΩ]	R _L [kΩ]	R _L [kΩ]	n _{max} [rpm]	R _A (20°C) [Ω]	L _A [mH]
TDP0,2LT-6	10	≥0.1	≥0.3	≥0.9	10000	3	6
TDP0,2LT-7	20	≥0.3	≥1.2	≥3.3	10000	11	23
TDP0,2LT-10	30	≥0.7	≥2.7	≥7.5	10000	26	50
TDP0,2LT-5	40	≥1.2	≥5	≥13.5	10000	47	90
TDP0,2LT-4	60	≥2.7	≥11	≥30	10000	99	200
TDP0,2LT-3	100	≥7.5	≥30	≥30	6000	271	550
TDP0,2LT-1	150	≥16	---	≥30	4000	630	1260

Superimposed ripple (for τ_{RC} = 0.7 ms): ≤0.5% (peak-peak) ≤0.2% (rms)

Replacement switching diagram

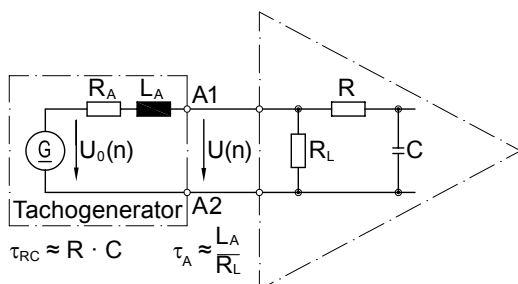

Polarity for positive rotating direction: A1: + (VDE)
A2: - (VDE)

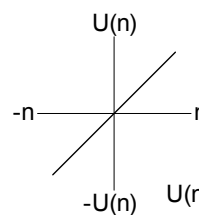

$$U(n) = U_0(n) \quad \frac{R_L}{R_A + R_L} \approx U_0(n) \text{ for } R > R_L \gg R_A$$

Combination

Tachogenerator with integrated electronic speed switch

Solid shaft with EURO flange B10

TDP 0,2 + ESL

Part number

Tachogenerator with speed switch ESL 93

TDP0,2 LT- **55 + ESL93** ...

- Switching speed 3 (ns3)
... 200...5000 rpm
- Switching speed 2 (ns2)
... 200...5000 rpm
- Switching speed 1 (ns1)
... 200...5000 rpm
- Mounting type
B10 EURO flange B10
B3 Housing foot
- Open-circuit voltage
6 10 mV per rpm
7 20 mV per rpm
10 30 mV per rpm
5 40 mV per rpm
4 60 mV per rpm
3 100 mV per rpm
1 150 mV per rpm

Please indicate the exact switching rotation speeds (permanent parameter defined at works).

Data according to type

Type	Open-circuit voltage U_0 [mV/rpm]	Minimum load required depending on speed range [rpm]			Maximum operating speed n_{max} [rpm]	Armature resistance R_A (20°C) [Ω]	Armature inductance L_A [mH]
		0-3000 R_L [kΩ]	0-6000 R_L [kΩ]	0- n_{max} R_L [kΩ]			
TDP0,2LT-6	10	≥0.1	≥0.3	≥0.9	10000	3	6
TDP0,2LT-7	20	≥0.3	≥1.2	≥3.3	10000	11	23
TDP0,2LT-10	30	≥0.7	≥2.7	≥7.5	10000	26	50
TDP0,2LT-5	40	≥1.2	≥5	≥13.5	10000	47	90
TDP0,2LT-4	60	≥2.7	≥11	≥30	10000	99	200
TDP0,2LT-3	100	≥7.5	≥30	≥30	6000	271	550
TDP0,2LT-1	150	≥16	---	≥30	4000	630	1260
Superimposed ripple (for $\tau_{RC} = 0.7$ ms):		≤0.5% (peak-peak)			≤0.2% (rms)		

Replacement switching diagram

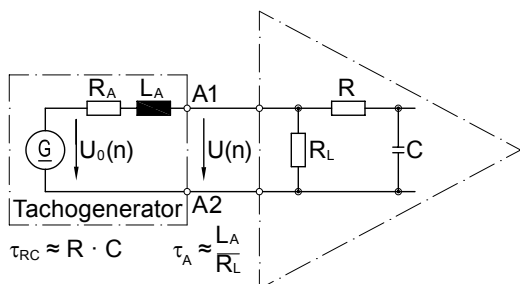

Polarity for positive rotating direction: A1: + (VDE)
A2: - (VDE)

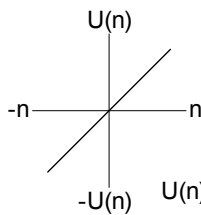

$$U(n) = U_0(n) \frac{R_L}{R_A + R_L} \approx U_0(n) \text{ for } R > R_L \gg R_A$$

Combination

Tachogenerator with integrated electronic speed switch

Solid shaft with EURO flange B10

TDP 0,2 + ESL

Terminal assignment

View A - Connecting terminal TDP 0,2

Polarity for positive direction of rotation

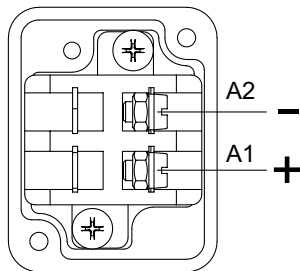

View B

Connecting terminal electronic speed switch ESL 90

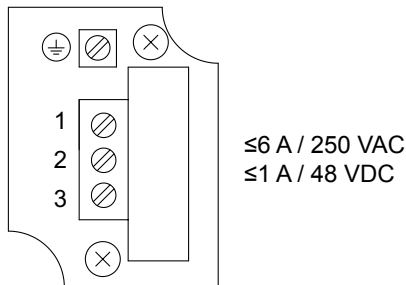

View B

Connecting terminal electronic speed switch ESL 93

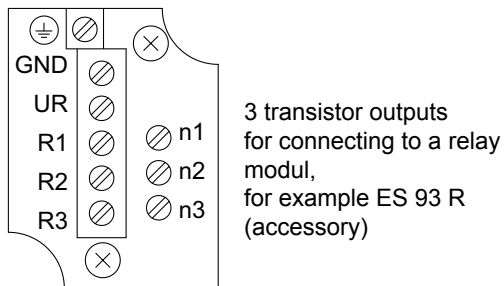

Accessories

Carbon brushes

Mounting accessories

K 35	Spring washer coupling for solid shaft $\varnothing 6...12$ mm
K 50	Spring washer coupling for solid shaft $\varnothing 11...16$ mm
K 60	Spring washer coupling for solid shaft $\varnothing 11...22$ mm

Combination

Tachogenerator with integrated electronic speed switch

Solid shaft with EURO flange B10

TDP 0,2 + ESL

Block circuit diagram

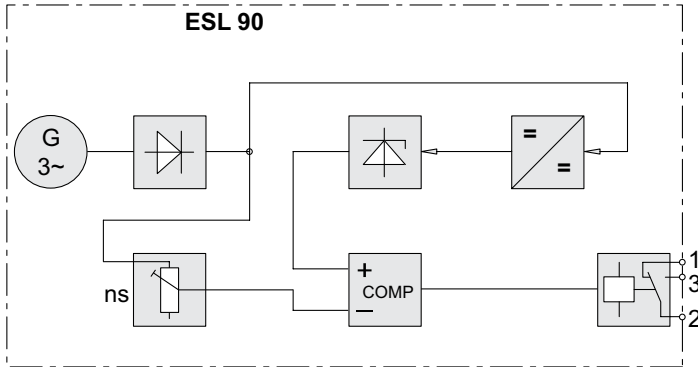

Switching characteristics

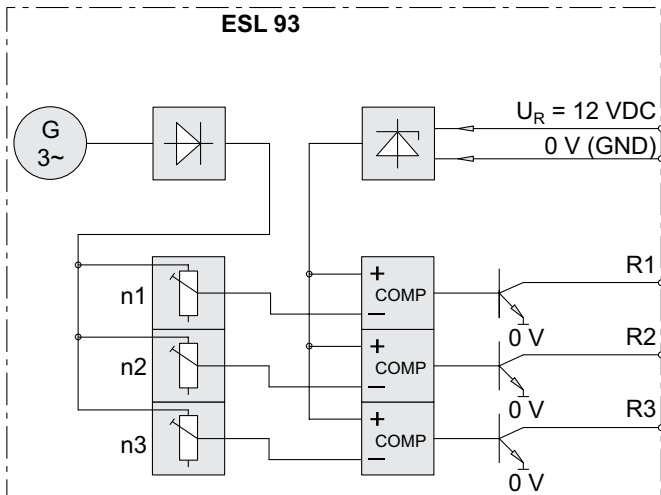
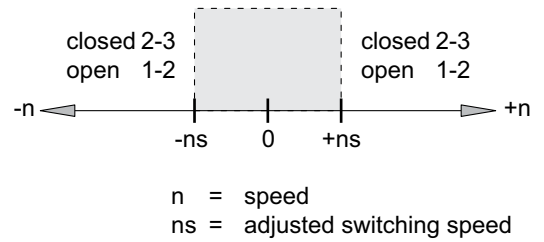

Recommended output circuit

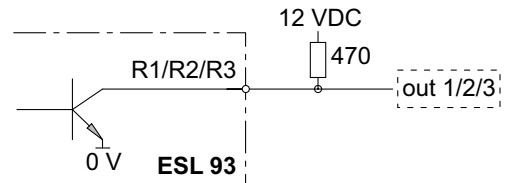

Switching characteristics

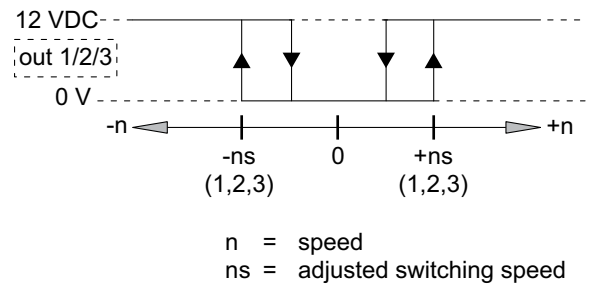

Combination

Tachogenerator with integrated electronic speed switch

Solid shaft with EURO flange B10

TDP 0,2 + ESL

Dimensions

TDP 0,2 + ESL - Version with Euro flange (B10)

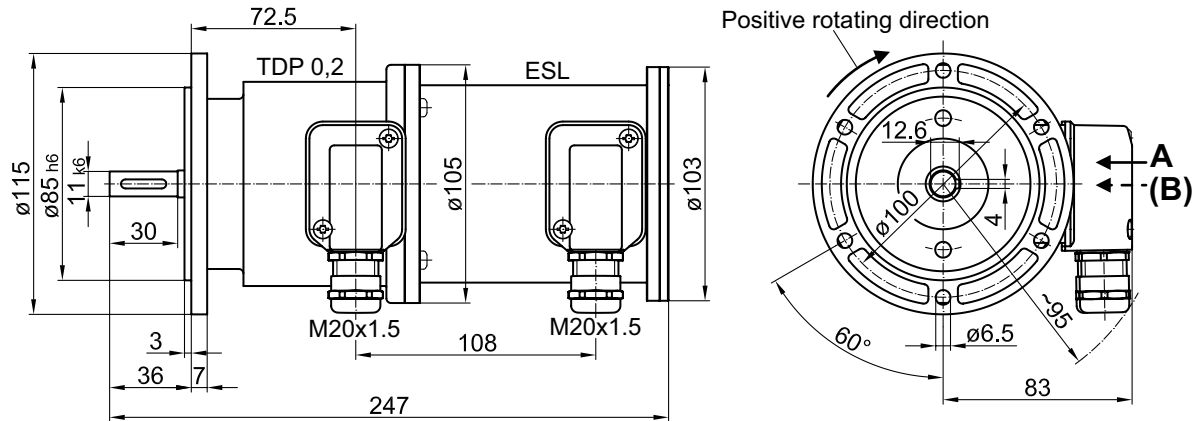

TDP 0,2 + ESL - Version with housing foot (B3)

