

**Distance sensors**

**OADM 20S4440/S14F**

**dimension drawing**

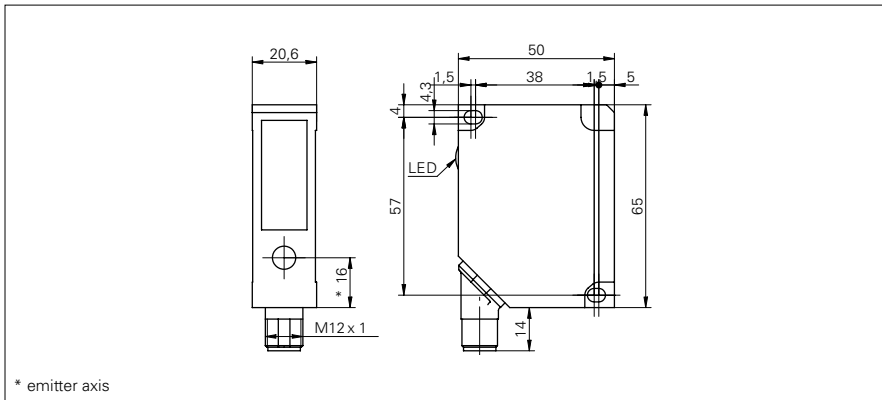

**general data**

measuring distance Sd	30 ... 50 mm
adjustment	no
power on indication	LED green
soiled lens indicator	LED red
resolution	< 0,01 mm
linearity error	± 0,03 mm
light source	pulsed red laser diode
wave length	650 nm
laser class	2
beam type	point
beam diameter	1 ... 0,4 mm
temperature drift	< 0,015 % Sde/K

**electrical data**

response time / release time	< 10 ms
voltage supply range +Vs	12 ... 28 VDC
current consumption max. (no load)	100 mA
output circuit	RS 485
baud rate	19200
output current	< 100 mA
alarm output	push-pull
short circuit protection	yes
reverse polarity protection	yes, Vs to GND

**mechanical data**

width / diameter	20,6 mm
height / length	65 mm
depth	50 mm
type	rectangular
housing material	die-cast zinc
front (optics)	glass
connection types	connector M12 8 pin, rotatable

**photo**



**connection diagram**

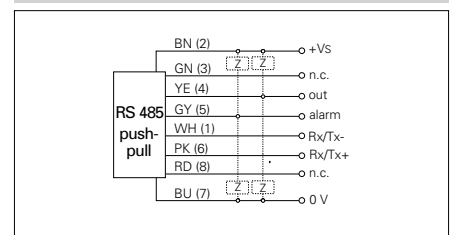

**laser warning**

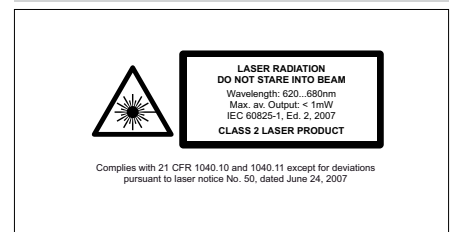

**Distance sensors****OADM 20S4440/S14F****ambient conditions**

ambient light immunity	< 10 kLux
operating temperature	0 ... +50 °C
protection class	IP 67