

Incremental encoders

Blind hollow shaft $\varnothing 16$ mm or cone shaft $\varnothing 17$ mm (1:10)

1024...10000 pulses per revolution

HOG 100



HOG 100 with radial terminal box

Features

- High resolution
- Blind hollow shaft $\varnothing 16$ mm or cone shaft $\varnothing 17$ mm (1:10)
- Optical sensing method
- Output stage HTL or TTL
- Output stage with regulator 9...26 VDC
- Hybrid bearing for extended lifetime
- Large terminal box, turn by 180° or axial terminal cover

Technical data - electrical ratings

Voltage supply	9...30 VDC 5 VDC ± 5 % 9...26 VDC
Consumption w/o load	≤ 100 mA
Pulses per revolution	1024...10000
Phase shift	90° ± 8 °
Scan ratio	44...56 %
Reference signal	Zero pulse, width 90°
Sensing method	Optical
Output frequency	≤ 250 kHz
Output signals	K1, K2, K0 + inverted
Output stages	HTL TTL/RS422
Interference immunity	EN 61000-6-2
Emitted interference	EN 61000-6-3
Approvals	CE, UL approval / E256710

Technical data - mechanical design

Size (flange)	$\varnothing 105$ mm
Shaft type	$\varnothing 16$ mm (blind hollow shaft) $\varnothing 17$ mm (cone shaft 1:10)
Admitted shaft load	≤ 450 N axial ≤ 600 N radial
Protection DIN EN 60529	IP 66
Operating speed	≤ 10000 rpm (mechanical)
Operating torque typ.	6 Ncm
Rotor moment of inertia	320 gcm ²
Materials	Housing: aluminium die-cast Shaft: stainless steel
Operating temperature	-30...+85 °C
Resistance	IEC 60068-2-6 Vibration 20 g, 10-2000 Hz IEC 60068-2-27 Shock 300 g, 6 ms
Corrosion protection	IEC 60068-2-52 Salt mist Complies to ISO 12944-5:1998 Protective paint systems (C4)
Explosion protection	II 3 G Ex nA IIC T4 Gc (gas) II 3 D Ex tc IIIC T135°C Dc (dust)
Connection	Terminal box Terminal cover
Weight approx.	1.5 kg

Subject to modification in technic and design. Errors and omissions excepted.

Incremental encoders

Blind hollow shaft \varnothing 16 mm or cone shaft \varnothing 17 mm (1:10)
1024...10000 pulses per revolution

HOG 100

Part number

Incremental encoder

HOG100 **DN**

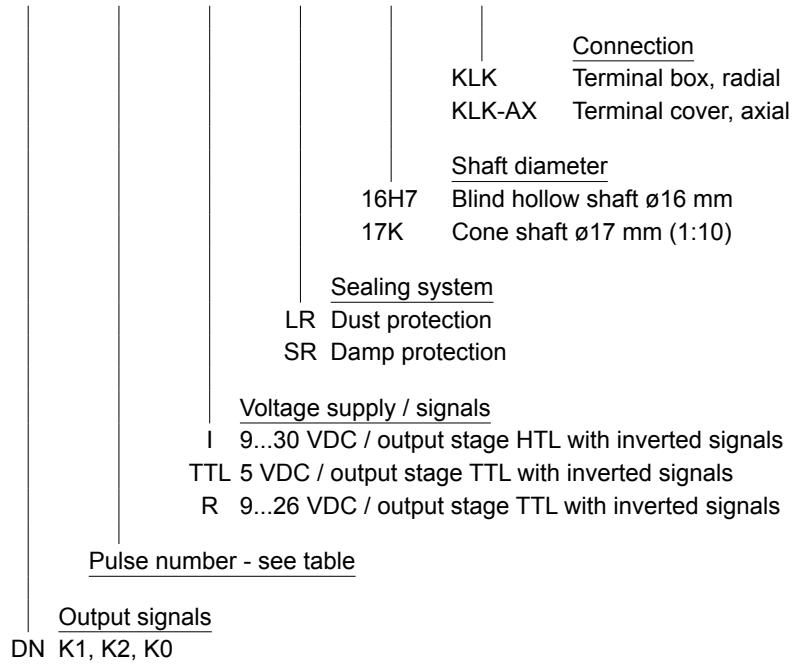

Pulse number

1024	2048	2500	4096	10000
2000	2160	3072	5000	

Other pulse numbers on request.

Accessories

Connectors and cables	
HEK 8	Sensor cable for encoders
Mounting accessories	
DMS 6	Torque arm size M6
Diagnostic accessories	
HENQ 1100	Analyzer for encoders

Incremental encoders

Blind hollow shaft $\varnothing 16$ mm or cone shaft $\varnothing 17$ mm (1:10)

1024...10000 pulses per revolution

HOG 100

Output signals

At positive rotating direction

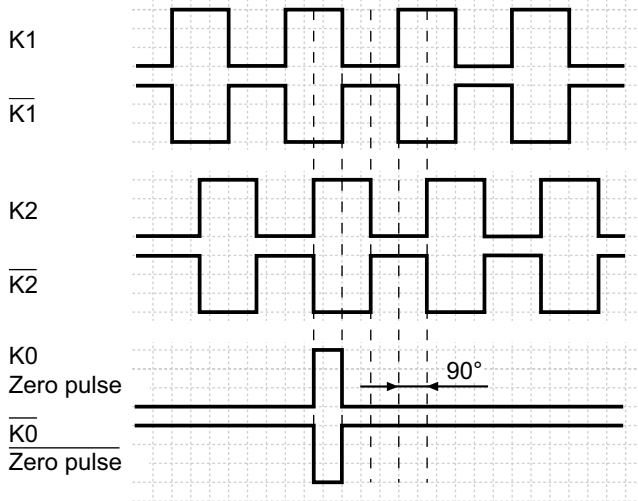

Terminal significance

+UB	Voltage supply (for the encoder)
\perp ; \downarrow ; GND; 0 V	Ground (for the signals)
\perp ; \nearrow	Earth ground (chassis)
K1; A; A+	Output signal channel 1
$\overline{K1}$; \overline{A} ; A-	Output signal channel 1 inverted
K2; B; B+	Output signal channel 2 (offset by 90° to channel 1)
$\overline{K2}$; \overline{B} ; B-	Output signal channel 2 (offset by 90° to channel 1) inverted
K0; C; R; R+	Zero pulse (reference signal)
$\overline{K0}$; \overline{C} ; \overline{R} ; R-	Zero pulse (reference signal) inverted

Terminal assignment

View A

Connecting terminal terminal box, radial

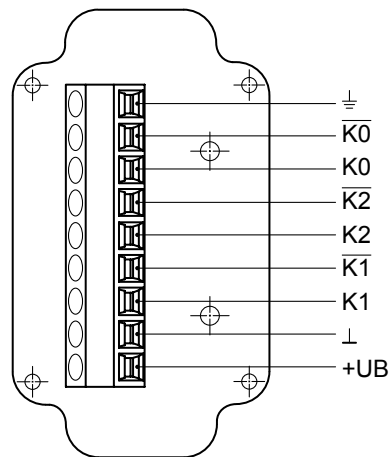

View B

Connecting terminal terminal cover, axial

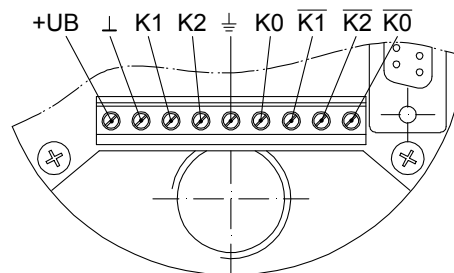

Incremental encoders

Blind hollow shaft $\varnothing 16$ mm or cone shaft $\varnothing 17$ mm (1:10)
1024...10000 pulses per revolution

HOG 100

Dimensions

HOG 100 - Version with radial terminal box

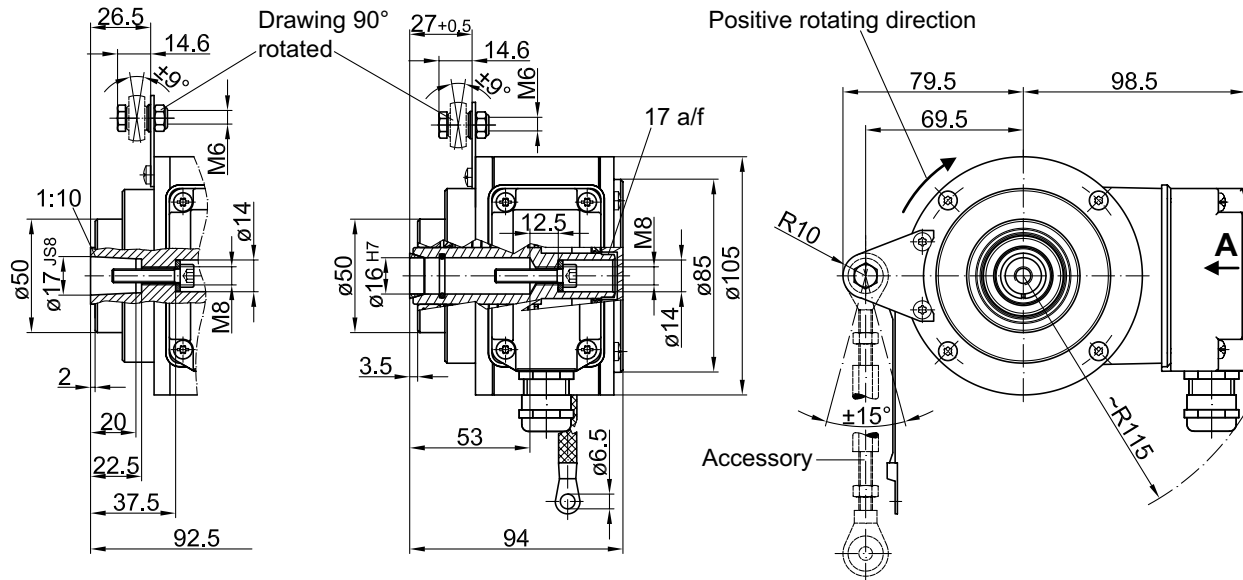

HOG 100 - Version with axial terminal cover

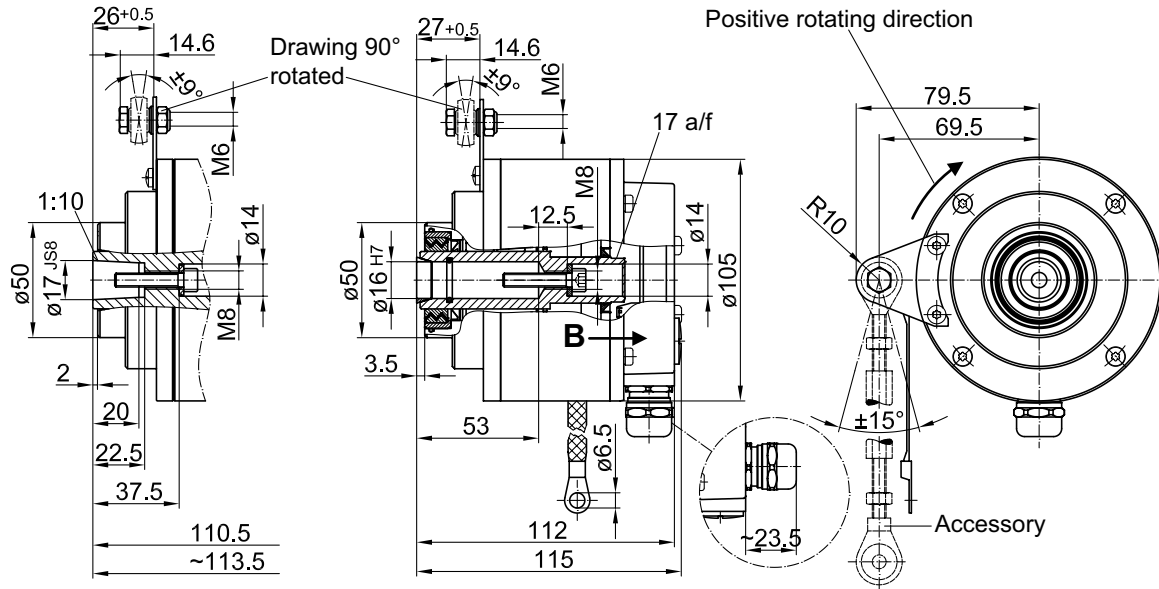

Subject to modification in technic and design. Errors and omissions excepted.