

Incremental encoders

Through hollow shaft $\varnothing 20$ to $\varnothing 38$ mm
250...2500 pulses per revolution

HOG 16



HOG 16

Technical data - electrical ratings

Voltage supply	9...30 VDC 5 VDC ± 5 % 9...26 VDC
Consumption w/o load	≤ 100 mA
Pulses per revolution	250...2500
Phase shift	$90^\circ \pm 20^\circ$
Scan ratio	40...60 %
Reference signal	Zero pulse, width 90°
Sensing method	Optical
Output frequency	≤ 120 kHz
Output signals	K1, K2, K0 + inverted
Output stages	HTL TTL/RS422
Interference immunity	EN 61000-6-2
Emitted interference	EN 61000-6-3
Approvals	CE, UL approval / E256710

Features

- Through hollow shaft $\varnothing 20$...38 mm
- Robust light-metal housing
- Output stage HTL or TTL
- Output stage TTL with regulator UB 9...26 VDC
- Special protection against corrosion
- Large terminal box, turn by 180°

Optional

- Redundant sensing with two terminal boxes
- With earthing brushes
- Hybrid bearing

Technical data - mechanical design

Size (flange)	$\varnothing 158$ mm
Shaft type	$\varnothing 20$...38 mm (through hollow shaft)
Admitted shaft load	≤ 450 N axial ≤ 600 N radial
Protection DIN EN 60529	IP 66
Operating speed	≤ 6000 rpm (mechanical)
Operating torque typ.	15 Ncm
Rotor moment of inertia	4.9 kgcm ² ($\varnothing 25$)
Materials	Housing: aluminium alloy Shaft: stainless steel
Operating temperature	-40 ... $+100$ °C
Resistance	IEC 60068-2-6 Vibration 20 g, 10-2000 Hz IEC 60068-2-27 Shock 300 g, 6 ms
Corrosion protection	IEC 60068-2-52 Salt mist Complies to ISO 12944-5:1998 Protective paint systems (C4)
Connection	Terminal box 2x terminal box (with option M)
Weight approx.	4.9 kg, 5.1 kg (with option M)

Incremental encoders

Through hollow shaft \varnothing 20 to \varnothing 38 mm
250...2500 pulses per revolution

HOG 16

Part number

Incremental encoder

HOG16

Shaft diameter

20H7	Through hollow shaft \varnothing 20 mm
24H7	Through hollow shaft \varnothing 24 mm
25H7	Through hollow shaft \varnothing 25 mm
28H7	Through hollow shaft \varnothing 28 mm
30H7	Through hollow shaft \varnothing 30 mm
32H7	Through hollow shaft \varnothing 32 mm
35H7	Through hollow shaft \varnothing 35 mm
38H7	Through hollow shaft \varnothing 38 mm

Voltage supply / signals

I	9...30 VDC / output stage HTL with inverted signals
TTL	5 VDC / output stage TTL with inverted signals
R	9...26 VDC / output stage TTL with inverted signals (for output signals DN)

Pulse number - see table

Output signals

D	K1, K2
DN	K1, K2, K0

Redundant sensing

	Without redundant sensing
M	With redundant sensing

Shaft type

	Standard ball bearings
C	With hybrid bearings

Pulse number

250	512	1000	1080	2048
500	600	1024	1200	2500

Other pulse numbers on request.

Accessories

Connectors and cables

HEK 8	Sensor cable for encoders
-------	---------------------------

Mounting accessories

DMS 6	Torque arm size M6
-------	--------------------

Diagnostic accessories

HENQ 1100	Analyzer for encoders
-----------	-----------------------

Incremental encoders

Through hollow shaft $\varnothing 20$ to $\varnothing 38$ mm

250...2500 pulses per revolution

HOG 16

Output signals

At positive rotating direction

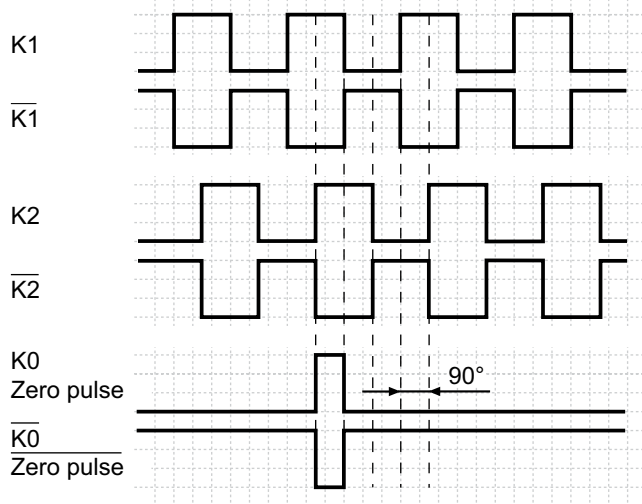

Terminal assignment

View A - Connecting terminal in terminal box

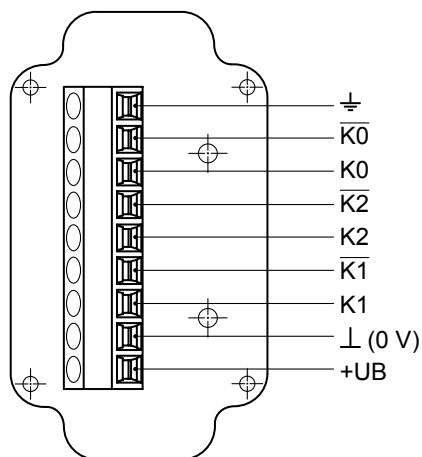

Incremental encoders

Through hollow shaft $\varnothing 20$ to $\varnothing 38$ mm
250...2500 pulses per revolution

HOG 16

Dimensions

HOG 16 - Version with single sensing

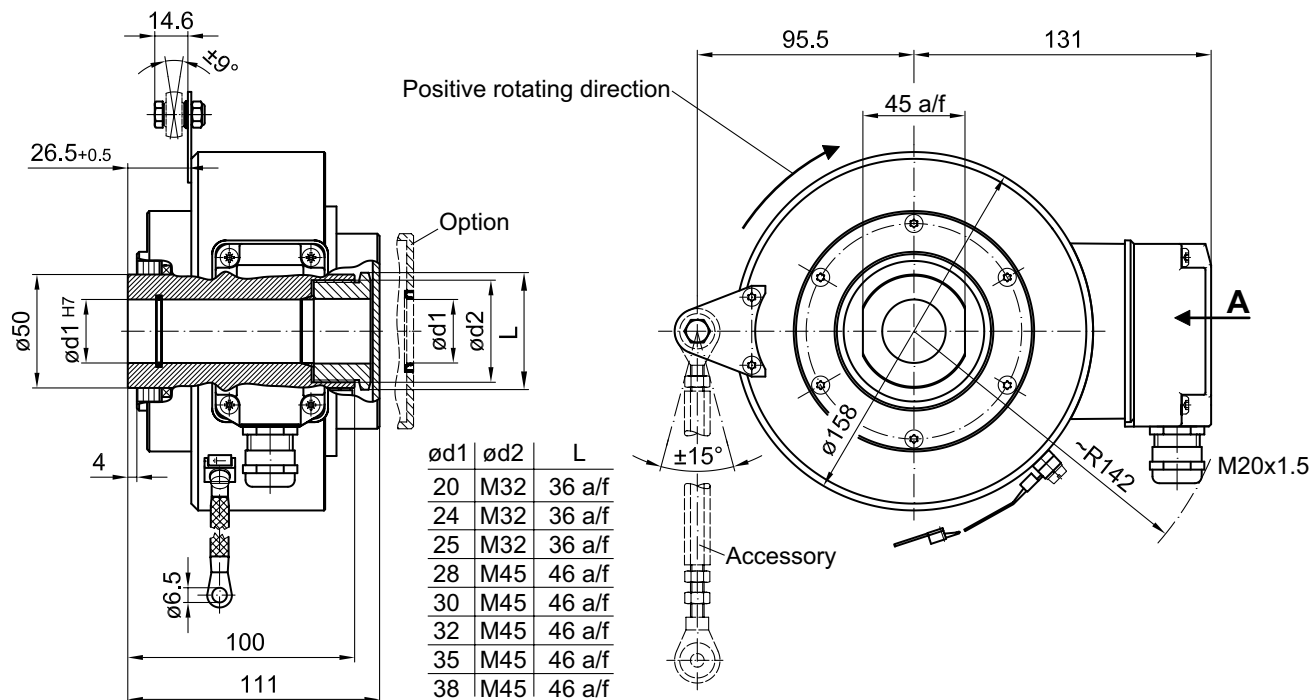

HOG 16 M - Version with redundant sensing

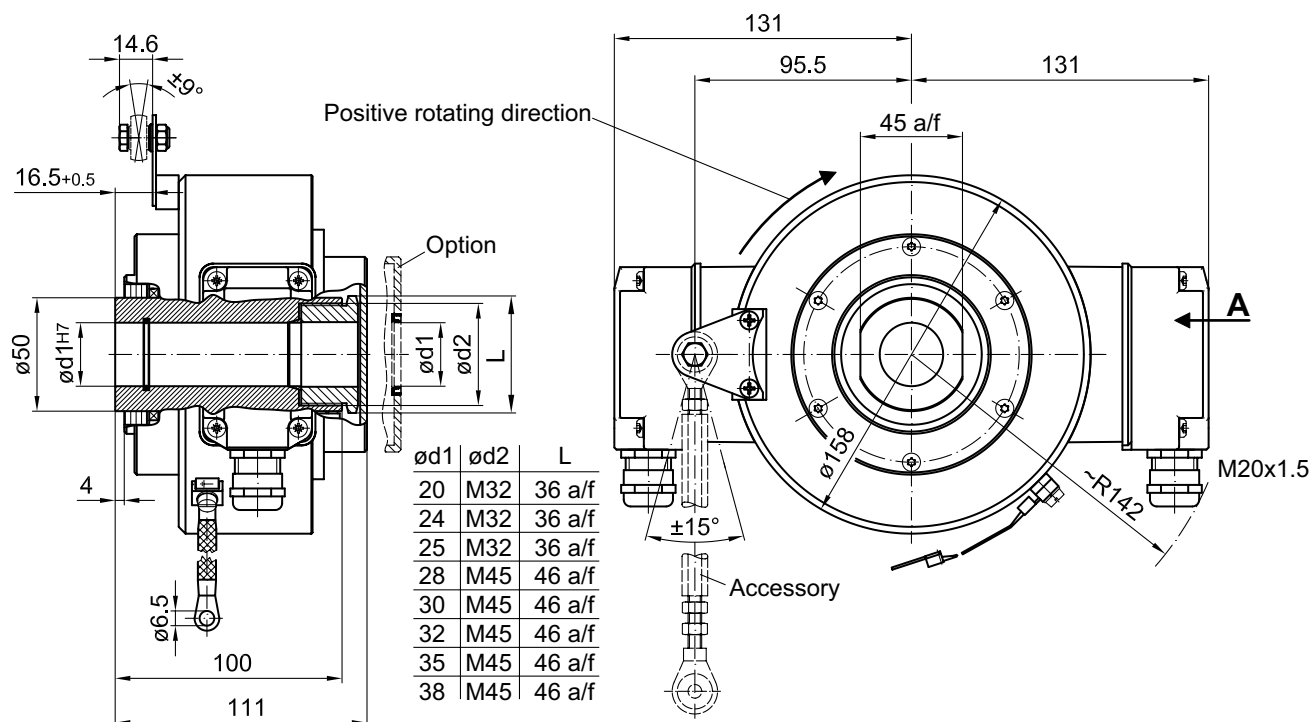

Subject to modification in technic and design. Errors and omissions excepted.