

Incremental encoders

Through hollow shaft $\varnothing 38$ to $\varnothing 75$ mm
250...5000 pulses per revolution

HOG 163



HOG 163

Technical data - electrical ratings

Voltage supply	9...30 VDC 5 VDC ± 5 % 9...26 VDC
Consumption w/o load	≤ 100 mA
Pulses per revolution	250...5000
Phase shift	$90^\circ \pm 20^\circ$
Scan ratio	40...60 %
Reference signal	Zero pulse, width 90°
Sensing method	Optical
Output frequency	≤ 120 kHz
Output signals	K1, K2, K0 + inverted
Output stages	HTL TTL/RS422
Interference immunity	EN 61000-6-2
Emitted interference	EN 61000-6-3
Approvals	CE, UL approval / E256710

Features

- Through hollow shaft $\varnothing 38$...75 mm
- Insulated constitution
- Optical sensing method
- Robust light-metal housing
- Output stage HTL or TTL
- Output stage TTL with regulator UB 9...26 VDC
- Special protection against corrosion
- Large terminal box, turn by 180°

Optional

- Redundant sensing with two terminal boxes
- Heating for applications up to -50°C (no explosion protection)

Technical data - mechanical design

Size (flange)	$\varnothing 158$ mm
Shaft type	$\varnothing 38$...75 mm (through hollow shaft)
Admitted shaft load	≤ 350 N axial, ≤ 500 N radial
Protection DIN EN 60529	IP 56
Operating speed	≤ 6000 rpm (mechanical)
Operating torque typ.	17 Ncm
Rotor moment of inertia	28.5 kgcm ² ($\varnothing 50$)
Materials	Housing: aluminium alloy Shaft: stainless steel
Operating temperature	-40 ... $+85^\circ\text{C}$
Resistance	IEC 60068-2-6 Vibration 10 g, 10-2000 Hz IEC 60068-2-27 Shock 100 g, 6 ms
Corrosion protection	IEC 60068-2-52 Salt mist Complies to ISO 12944-5:1998 Protective paint systems (C4)
Explosion protection	II 3 G Ex nA IIC T4 Gc (gas) II 3 D Ex tc IIIB T135°C Dc (dust)
Connection	Terminal box 2x terminal box (with option M)
Weight approx.	5.4 kg ($\varnothing 48$), 3.5 kg ($\varnothing 75$), 3.9 kg ($\varnothing 75$ with option M)

Subject to modification in technic and design. Errors and omissions excepted.

Incremental encoders

Through hollow shaft $\varnothing 38$ to $\varnothing 75$ mm
250...5000 pulses per revolution

HOG 163

Part number

Incremental encoder

HOG163 **DN**

Shaft diameter

38H7	Through hollow shaft $\varnothing 38$ mm
50H7	Through hollow shaft $\varnothing 50$ mm
55H7	Through hollow shaft $\varnothing 55$ mm
56H7	Through hollow shaft $\varnothing 56$ mm
60H7	Through hollow shaft $\varnothing 60$ mm
65H7	Through hollow shaft $\varnothing 65$ mm
70H7	Through hollow shaft $\varnothing 70$ mm
75H7	Through hollow shaft $\varnothing 75$ mm

Voltage supply / signals

I	9...30 VDC / output stage HTL with inverted signals
TTL	5 VDC / output stage TTL with inverted signals
R	9...26 VDC / output stage TTL with inverted signals

Pulse number - see table

Output signals

DN K1, K2, K0

Redundant sensing

- Without redundant sensing
- M With redundant sensing

Pulse number

250	1000	1200	4096
500	1024	2048	5000
512	1080	2500	

Other pulse numbers on request.

Accessories

Connectors and cables

HEK 8 Sensor cable for encoders

Mounting accessories

DMS 6 Torque arm size M6

Diagnostic accessories

HENQ 1100 Analyzer for encoders

Subject to modification in technic and design. Errors and omissions excepted.

Incremental encoders

Through hollow shaft $\varnothing 38$ to $\varnothing 75$ mm

250...5000 pulses per revolution

HOG 163

Output signals

At positive rotating direction

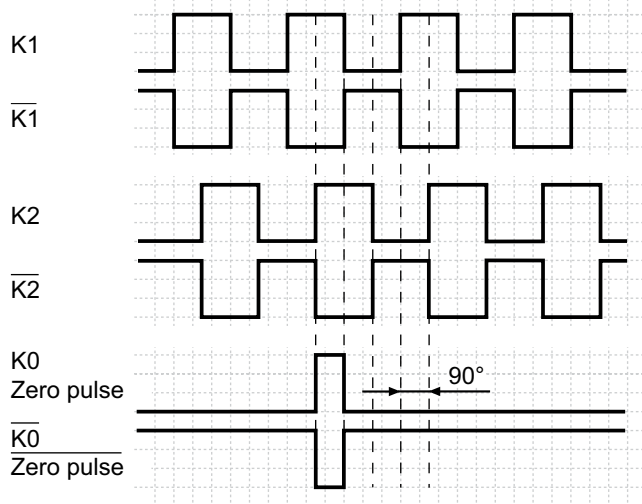

Terminal assignment

View A - Connecting terminal in terminal box

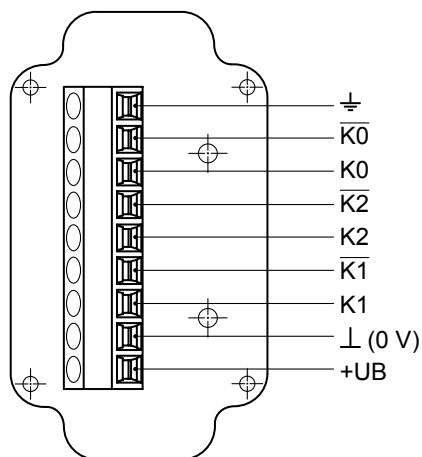

Incremental encoders

Through hollow shaft $\varnothing 38$ to $\varnothing 75$ mm
250...5000 pulses per revolution

HOG 163

Dimensions

HOG 163 - Version with single sensing

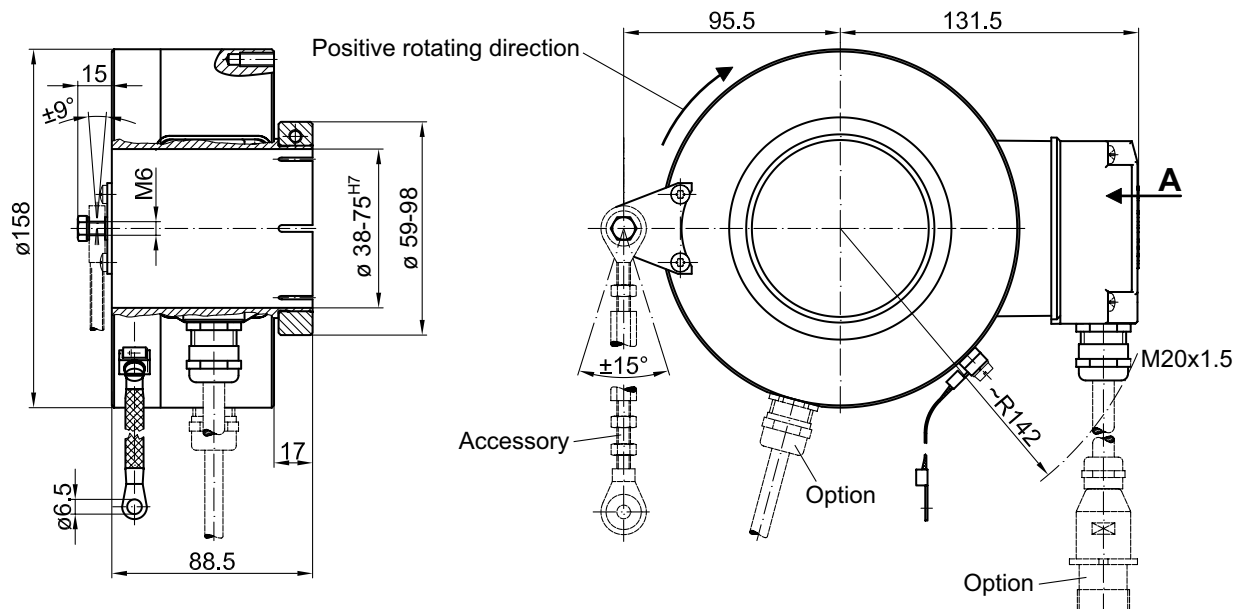

HOG 163 - Version with redundant sensing

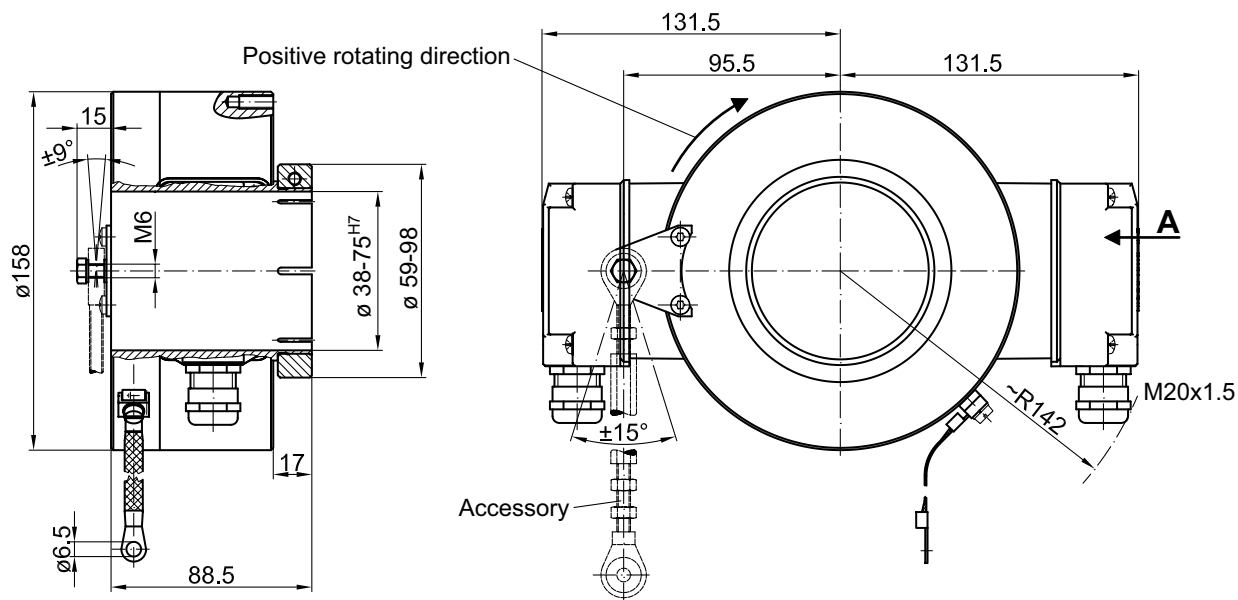

Subject to modification in technic and design. Errors and omissions excepted.