

Incremental encoders

Blind hollow shaft $\varnothing 20...38$ mm
1024...8192 pulses per revolution

HOG 165

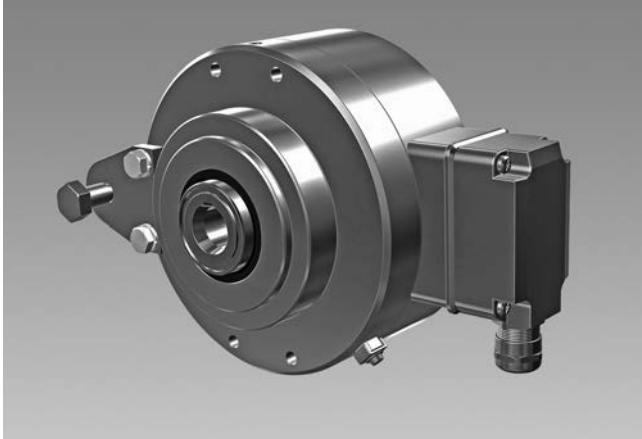

HOG 165

Technical data - electrical ratings

Voltage supply	9...30 VDC 5 VDC $\pm 5\%$ 9...26 VDC
Consumption w/o load	≤ 100 mA
Pulses per revolution	1024...8192
Phase shift	$90^\circ \pm 20^\circ$
Scan ratio	40...60 %
Reference signal	Zero pulse, width 90°
Sensing method	Optical
Output frequency	≤ 120 kHz
Output signals	K1, K2, K0 + inverted
Output stages	HTL TTL/RS422
Shaft insulation	2.8 kV
Interference immunity	EN 61000-6-2
Emitted interference	EN 61000-6-3
Approvals	CE, UL approval / E256710

Features

- Extremely high resistance to shock and vibrations
- Blind hollow shaft up to $\varnothing 38$ mm
- Output stage HTL or TTL
- High protection IP 67, shaft insulation up to 2.8 kV
- Surface protection scratch and impact resistant
- Corrosion protection acc. to 12944-5:1998 (C5M)
- Large terminal box, turn by 180°

Optional

- Large torque support plate
- Redundant sensing with two terminal boxes
- With earthing brushes

Technical data - mechanical design

Size (flange)	$\varnothing 165$ mm
Shaft type	$\varnothing 20...38$ mm (blind hollow shaft)
Admitted shaft load	≤ 500 N axial ≤ 650 N radial
Protection DIN EN 60529	IP 67
Operating speed	≤ 6000 rpm (mechanical)
Operating torque typ.	15 Ncm
Rotor moment of inertia	4.9 kgcm ²
Materials	Housing: aluminium alloy Shaft: stainless steel
Operating temperature	$-40...+100$ °C
Resistance	IEC 60068-2-6 Vibration 20 g, 10-2000 Hz IEC 60068-2-27 Shock 300 g, 6 ms
Corrosion protection	IEC 60068-2-52 Salt mist Complies to ISO 12944-5:1998 Protective paint systems (C5-M)
Explosion protection	II 3 G Ex nA IIC T4 Gc (gas) II 3 D Ex tc IIIC T135°C Dc (dust)
Connection	Terminal box
Weight approx.	6.1 kg

Incremental encoders

Blind hollow shaft ø20...38 mm

1024...8192 pulses per revolution

HOG 165

Part number

Incremental encoder

HOG165 **DN** **KLK**

Connection
KLK Terminal box, radial

Shaft diameter
 20H7 Blind hollow shaft ø20 mm
 20H7 PF Blind hollow shaft ø20 mm with keyway
 25H7 Blind hollow shaft ø25 mm
 25H7 PF Blind hollow shaft ø25 mm with keyway
 28H7 Blind hollow shaft ø28 mm
 28H7 PF Blind hollow shaft ø28 mm with keyway
 32H7 Blind hollow shaft ø32 mm
 36H7 Blind hollow shaft ø36 mm
 38H7 Blind hollow shaft ø38 mm

Voltage supply / signals
 I 9...30 VDC / output stage HTL with inverted signals
 TTL 5 VDC / output stage TTL with inverted signals
 R 9...26 VDC / output stage TTL with inverted signals

Pulse number - see table

Output signals
DN K1, K2, K0

Redundant sensing
Without redundant sensing
M With redundant sensing

Pulse number

1024	2500	5000
2048	4096	8192

Accessories

Connectors and cables

HEK 8 Sensor cable for encoders

Mounting accessories

DMS 12 Torque arm size M12

Diagnostic accessories

HENQ 1100 Analyzer for encoders

Incremental encoders

Blind hollow shaft $\varnothing 20...38$ mm

1024...8192 pulses per revolution

HOG 165

Output signals

At positive rotating direction

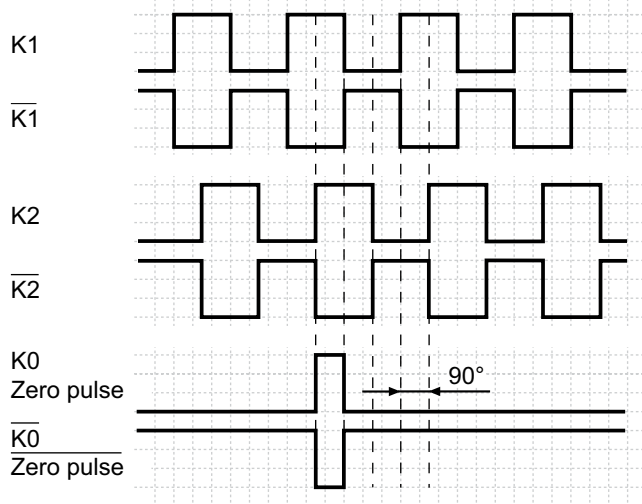

Terminal assignment

View A - Connecting terminal in terminal box

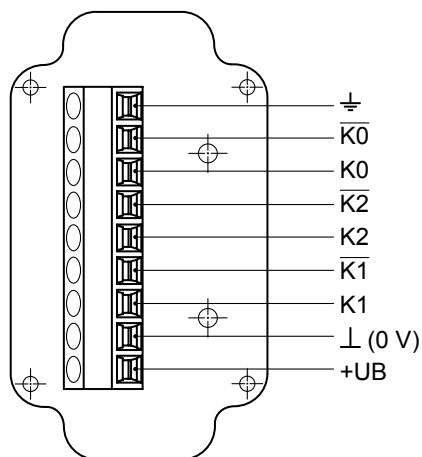

Incremental encoders

Blind hollow shaft $\varnothing 20...38$ mm
1024...8192 pulses per revolution

HOG 165

Dimensions

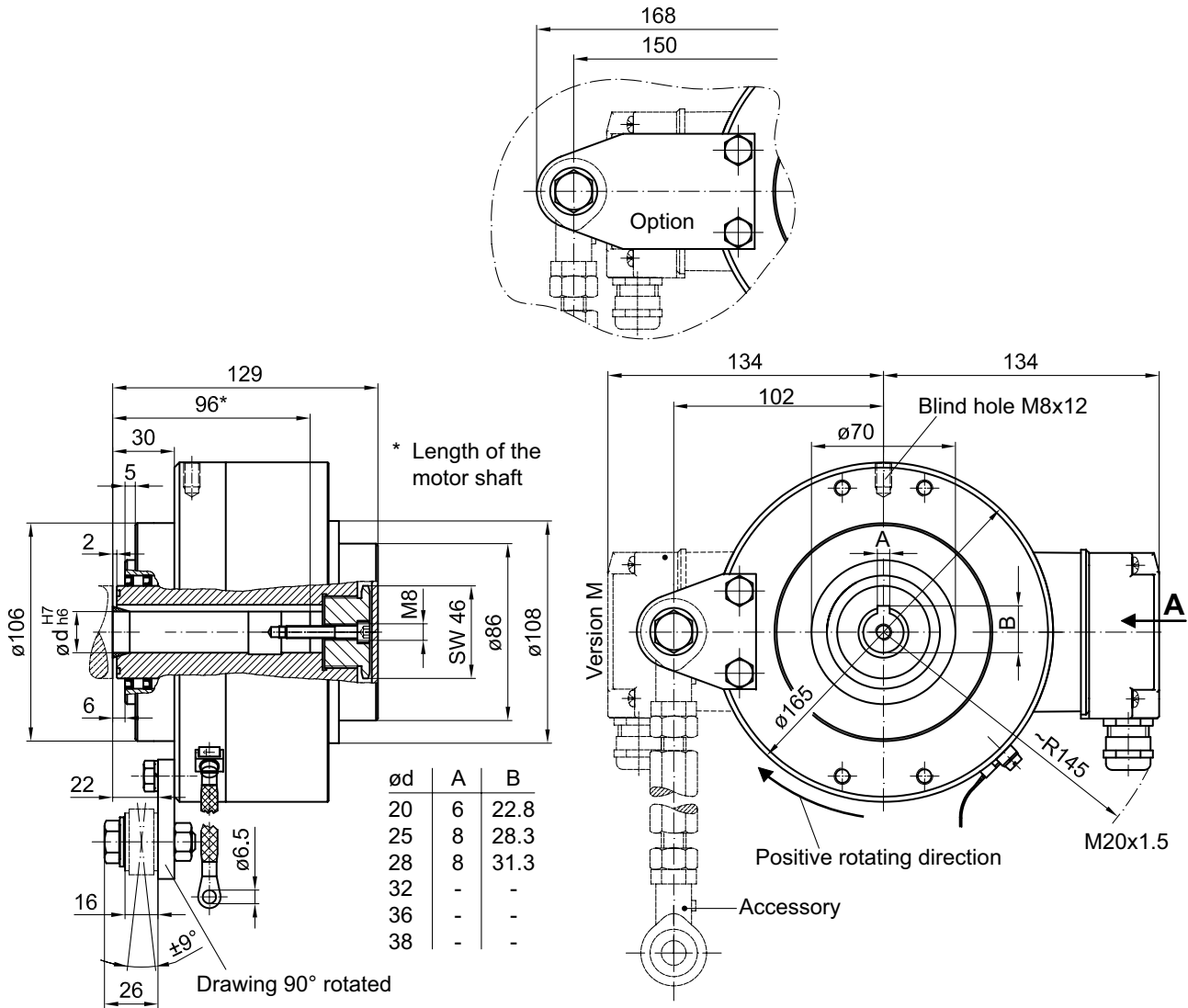

Subject to modification in technic and design. Errors and omissions excepted.