

Incremental encoders

Through hollow shaft $\varnothing 10...16$ mm
1...5000 pulses per revolution

HOG 8



HOG 8

Features

- Through hollow shaft $\varnothing 10...16$ mm
- Optical sensing method
- Compact, robust die-cast housing
- Output stage HTL or TTL
- Output stage TTL with regulator UB 9...26 VDC

Optional

- Cone shaft $\varnothing 17$ mm (1:10)
- Option 1: Torque sheet
- Option 2: Support plate for torque arm

Technical data - electrical ratings

Voltage supply	9...26 VDC 5 VDC ± 5 %
Consumption w/o load	≤ 100 mA
Pulses per revolution	1...5000
Phase shift	$90^\circ \pm 20^\circ$
Scan ratio	40...60 %
Reference signal	Zero pulse, width 90°
Sensing method	Optical
Output frequency	≤ 120 kHz ≤ 300 kHz (on request)
Output signals	K1, K2, K0 + inverted
Output stages	HTL TTL/RS422
Interference immunity	EN 61000-6-2
Emitted interference	EN 61000-6-3
Approvals	CE, UL approval / E256710

Technical data - mechanical design

Size (flange)	$\varnothing 86.5$ mm
Shaft type	$\varnothing 10...16$ mm (through hollow shaft)
Admitted shaft load	≤ 100 N axial ≤ 200 N radial
Protection DIN EN 60529	IP 54
Operating speed	≤ 12000 rpm (mechanical)
Operating torque typ.	1 Ncm
Rotor moment of inertia	18 gcm ²
Materials	Housing: aluminium die-cast Shaft: stainless steel
Operating temperature	$-30...+85$ °C $-25...+85$ °C (> 3072 pulses per revolution)
Resistance	IEC 60068-2-6 Vibration 10 g, 20-2000 Hz IEC 60068-2-27 Shock 100 g, 6 ms
Connection	Connecting terminal
Weight approx.	650 g

Incremental encoders

Through hollow shaft $\varnothing 10...16$ mm
1...5000 pulses per revolution

HOG 8

Part number

Incremental encoder

HOG8 DN

Shaft diameter
10H7 Through hollow shaft $\varnothing 10$ mm
12H7 Through hollow shaft $\varnothing 12$ mm
14H7 Through hollow shaft $\varnothing 14$ mm
15H7 Through hollow shaft $\varnothing 15$ mm
16H7 Through hollow shaft $\varnothing 16$ mm

Voltage supply / signals
C 9...26 VDC / output stage HTL (C) (for output signals D)
CI 9...26 VDC / output stage HTL (C) with inverted signals (for output signals DN)
TTL 5 VDC / output stage TTL with inverted signals
R 9...26 VDC / output stage TTL with inverted signals (for output signals DN)

Pulse number - see table

Output signals

DN K1, K2, K0

Accessories

Connectors and cables

HEK 8 Sensor cable for encoders

Mounting accessories

DMS 6 Torque arm size M6

Diagnostic accessories

HENQ 1100 Analyzer for encoders

Pulse number

1	12	62	300	1024
2	15	64	360	1042
3	20	100	400	1200
4	25	120	500	1250
5	30	176	512	2048
6	36	180	600	2500
8	40	192	720	3072
10	50	200	900	4096
11	60	250	1000	5000

Other pulse numbers on request.

Incremental encoders

Through hollow shaft $\varnothing 10 \dots 16$ mm
1...5000 pulses per revolution

HOG 8

Output signals

At positive rotating direction

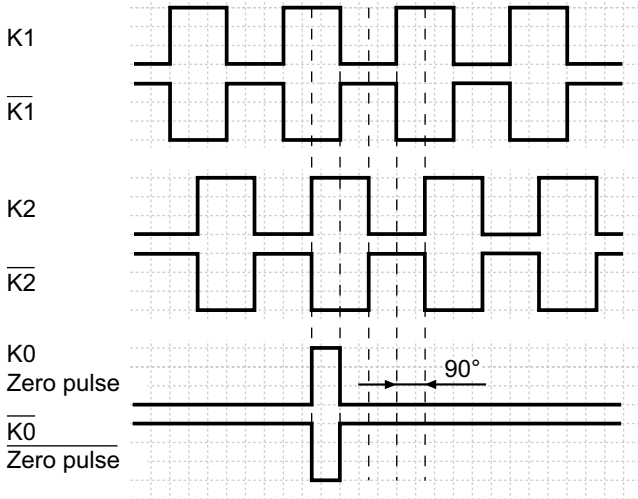

Terminal assignment

View A - Connecting terminal

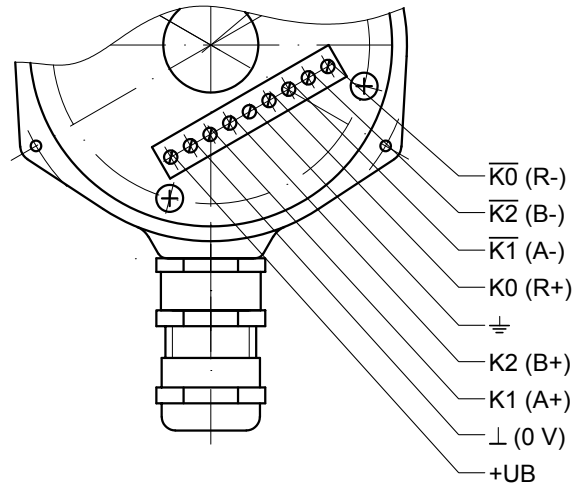

Dimensions

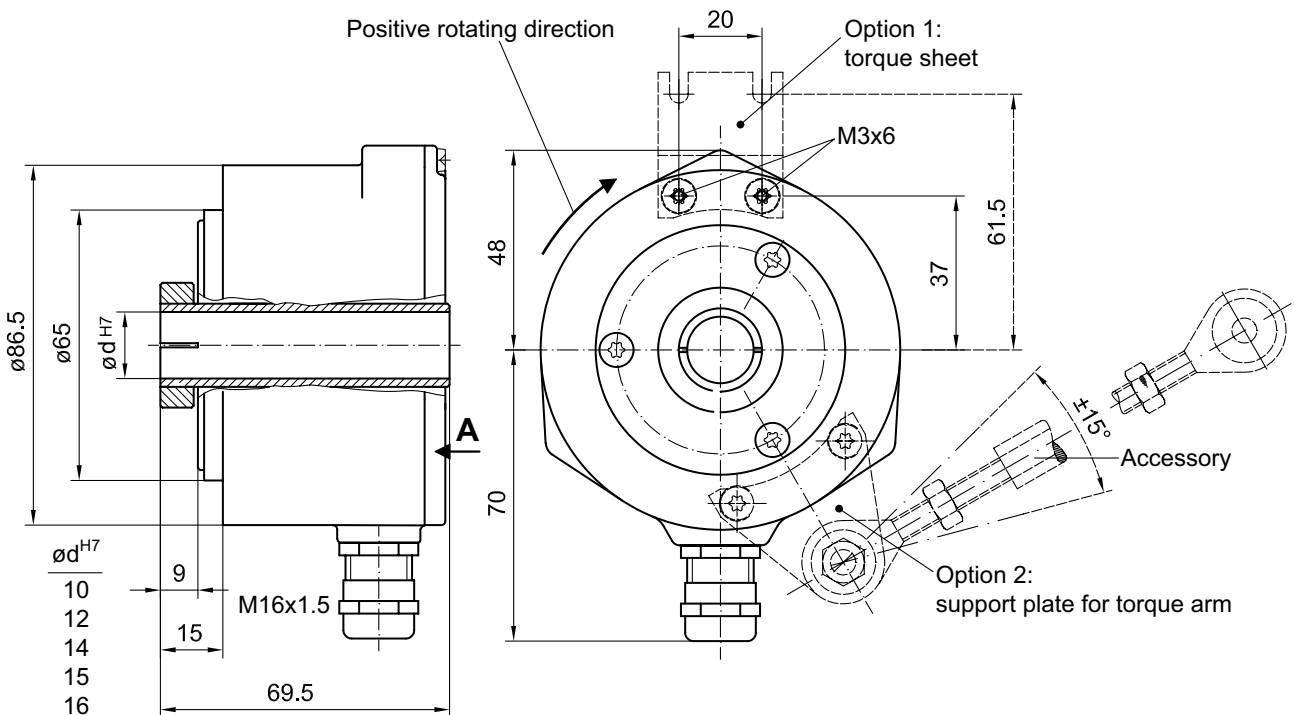

Incremental encoders

Through hollow shaft $\varnothing 10...16$ mm
1...5000 pulses per revolution

HOG 8
