

Incremental encoders

Solid shaft $\varnothing 6$ mm with synchro flange

1000...10000 pulses per revolution

ITD 21 B14



ITD 21 B14 with synchro flange

Technical data - electrical ratings

Voltage supply	5 VDC ± 5 % 8...30 VDC
Reverse polarity protection	Yes
Consumption w/o load	≤ 100 mA
Pulses per revolution	1000...10000
Reference signal	Zero pulse, width 90°
Sensing method	Optical
Output frequency	≤ 300 kHz (TTL) ≤ 160 kHz (HTL)
Output signals	A, B, N + inverted
Output stage	TTL linedriver (short-circuit proof) HTL push-pull (short-circuit proof)
Interference immunity	DIN EN 61000-6-2
Emitted interference	DIN EN 61000-6-3

Features

- Encoder with solid shaft $\varnothing 6$ mm
- Max. 10000 pulses per revolution
- Optical sensing
- Centering alignment $\varnothing 50$ mm, mounting screw hole circle $\varnothing 68$ mm
- Industrial standard
- TTL or HTL output signals
- Cable output radial or axial

Optional

- Cable with connector
- Extended operating temperature range

Technical data - mechanical design

Size (flange)	$\varnothing 58$ mm
Shaft type	$\varnothing 6$ mm solid shaft (synchro flange)
Shaft loading	≤ 20 N axial ≤ 40 N radial
Flange	Synchro flange
Protection DIN EN 60529	IP 65
Operating speed	≤ 12000 rpm
Starting torque	≤ 0.01 Nm (+20 °C)
Materials	Housing: aluminium, black, powder-coated Shaft: stainless steel
Operating temperature	-20...+70 °C -20...+100 °C
Relative humidity	90 % non-condensing
Resistance	DIN EN 60068-2-6 Vibration 10 g, 55-2000 Hz DIN EN 60068-2-27 Shock 30 g, 11 ms
Connection	Cable 1 m
Weight approx.	400 g

Incremental encoders

Solid shaft $\varnothing 6$ mm with synchro flange
1000...10000 pulses per revolution

ITD 21 B14

Part number

ITD 21 B14

		NI			6	IP65
--	--	----	--	--	---	------

		NI			6	IP65
Protection						
IP65 IP 65						
Flange / Solid shaft						
6 Synchro flange / $\varnothing 6$ mm						
Operating temperature						
S -20...+70 °C						
E -20...+100 °C						
Connection						
KR1 Cable 1 m, radial						
KA1 Cable 1 m, axial						
Output signals						
NI A, A inv, B, B inv, 0, 0 inv						
Voltage supply / signals						
T 5 VDC / TTL level, linedriver						
H 8...30 VDC / HTL level, push pull						
R 8...30 VDC / TTL level, linedriver						

Pulse number - see table

Pulse number

1000	1440	2048	4000	7200*
1024	1500	2500	4096	8192*
1200	1800	3000	5000	9000*
1250	2000	3600	6000	10000*

* Observe terminal assignment!

Accessories

Mounting accessories

11065545	Set of eccentric fixings type A
----------	---------------------------------

Incremental encoders

Solid shaft $\varnothing 6$ mm with synchro flange

1000...10000 pulses per revolution

ITD 21 B14

Output signals

Clockwise rotation when looking at the mounting side.

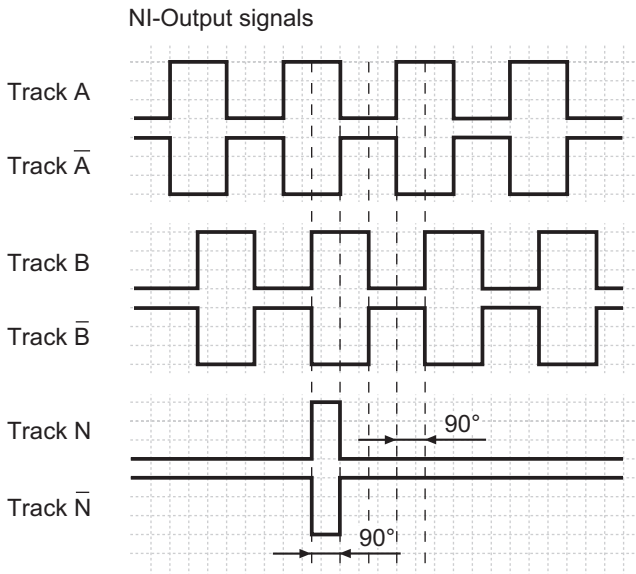

Terminal assignment

Pulses per revolution ≤ 6000

Core colour	Assignment
brown	Track A
green	Track A inv.
grey	Track B
pink	Track B inv.
red	Track N
black	Track N inv.
brown 0,5 mm ²	UB
white 0,5 mm ²	GND
blue	UB-Sense
white	GND-Sense
transparent	Shield/Housing

Pulses per revolution > 6000

Core colour	Assignment
green	Track A
brown	Track A inv.
grey	Track B
black	Track B inv.
pink	Track N
white	Track N inv.
red	UB
blue	GND
yellow	UB-Sense
violet	GND-Sense
transparent	Shield/Housing

Trigger level

Outputs	Linedriver
Output level High	≥ 2.4 V
Output level Low	≤ 0.5 V
Load	≤ 70 mA

Outputs	Push-pull short-circuit proof
Output level High	$\geq UB - 3$ V
Output level Low	≤ 1.5 V
Load	≤ 70 mA

Incremental encoders

Solid shaft $\varnothing 6$ mm with synchro flange
1000...10000 pulses per revolution

ITD 21 B14

Dimensions

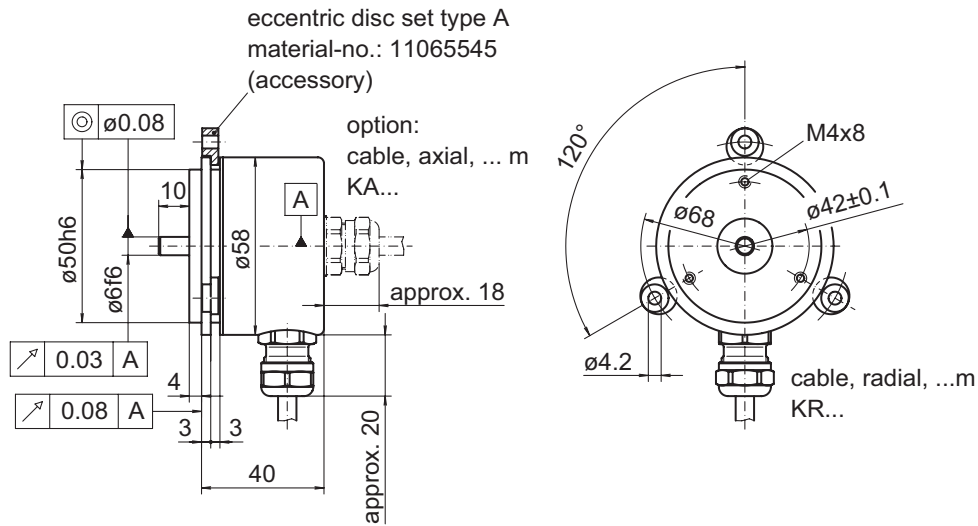

027-4