

Combination

Encoder with integrated centrifugal switch

Solid shaft with EURO flange B10

1024...10000 pulses per revolution

POG 90 + FSL

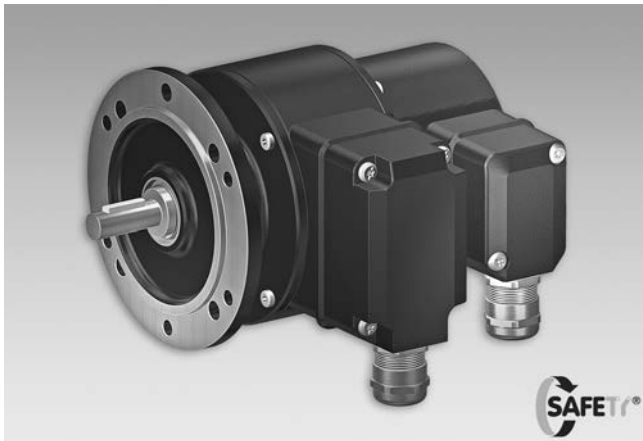

POG 90 + FSL

Features

- Max. 10000 pulses per revolution
- Mechanical speed monitoring based on centrifugal force
- EURO-flange B10 / solid shaft $\varnothing 11$ mm
- Terminal boxes, turn by 180°

Technical data - electrical ratings

Interference immunity	EN 61000-6-2
Emitted interference	EN 61000-6-3
Approval	CE

Technical data - electrical ratings (encoder)

Voltage supply	9...30 VDC 5 VDC ± 5 %
Consumption w/o load	≤ 100 mA
Pulses per revolution	1024...10000
Phase shift	90° ± 8 °
Scan ratio	44...56 %
Reference signal	Zero pulse, width 90°
Output frequency	≤ 250 kHz
Output signals	K1, K2, K0 + inverted
Output stages	HTL TTL/RS422
Sensing method	Optical

Technical data - electrical ratings (centrifugal switch)

Switching accuracy	± 4 % ($\Delta n = 2$ rpm/s); = +20 % ($\Delta n = 1500$ rpm/s)
Switching deviation	≤ 3 % (cw-ccw rotation)
Switching hysteresis	~ 40 % of switching speed
Switching outputs	1 output, speed control
Output switching capacity	≤ 6 A / 230 VAC ≤ 1 A / 125 VDC
Minimum switching current	50 mA

Technical data - mechanical design

Size (flange)	$\varnothing 115$ mm
Shaft type	$\varnothing 11$ mm solid shaft
Admitted shaft load	≤ 250 N axial ≤ 350 N radial
Flange	EURO flange B10
Protection DIN EN 60529	IP 66
Speed (n)	$\leq 1.25 \cdot ns$
Range of switching speed (ns)	850...4500 rpm ($\Delta n = 2$ rpm/s)
Operating torque typ.	3 Ncm
Rotor moment of inertia	320 gcm ²
Materials	Housing: aluminium die-cast Shaft: stainless steel
Operating temperature	-20...+85 °C
Resistance	IEC 60068-2-6 Vibration 5 g, 10-2000 Hz IEC 60068-2-27 Shock 50 g, 11 ms
Corrosion protection	IEC 60068-2-52 Salt mist Complies to ISO 12944-5:1998 Protective paint systems (C4)
Connection	2x terminal box
Weight approx.	2.6 kg

Combination

Encoder with integrated centrifugal switch
Solid shaft with EURO flange B10
1024...10000 pulses per revolution

POG 90 + FSL

Part number

Incremental encoder with centrifugal force switch FSL

POG90

DN						+ FSL	
----	--	--	--	--	--	-------	--

					<u>Switching speed (ns)</u>
					6 850...949 rpm ($\Delta n = 2$ rpm/s)*
					5 950...1099 rpm ($\Delta n = 2$ rpm/s)*
					4 1100...1299 rpm ($\Delta n = 2$ rpm/s)*
					3 1300...1799 rpm ($\Delta n = 2$ rpm/s)*
					2 1800...2499 rpm ($\Delta n = 2$ rpm/s)*
					1 2500...4500 rpm ($\Delta n = 2$ rpm/s)*
					<u>Voltage supply / signals</u>
					I 9...30 VDC / output stage HTL with inverted signals
					TTL 5 VDC / output stage TTL with inverted signals
					R 9...30 VDC / output stage TTL with inverted signals
					<u>Pulse number - see table</u>
					<u>Output signals</u>
					DN K1, K2, K0

Pulse number

1024	2048	3072	4096	10000
2000	2500	3600	5000	

Other pulse numbers on request.

* Please specify the exact switching speed in addition to the part number (factory setted threshold).

Combination

Encoder with integrated centrifugal switch

Solid shaft with EURO flange B10

1024...10000 pulses per revolution

POG 90 + FSL

Output signals

At positive rotating direction

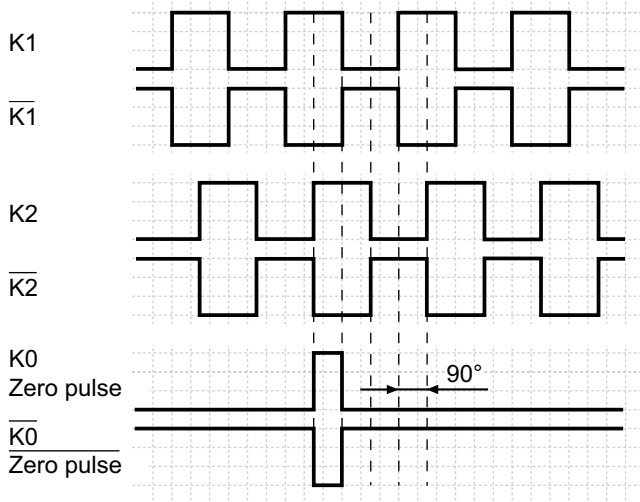

Accessories

Connectors and cables

HEK 8 Sensor cable for encoders

Mounting accessories

K 35 Spring washer coupling for solid shaft $\varnothing 6...12$ mm

K 50 Spring washer coupling for solid shaft $\varnothing 11...16$ mm

K 60 Spring washer coupling for solid shaft $\varnothing 11...22$ mm

Diagnostic accessories

HENQ 1100 Analyzer for encoders

Terminal assignment

View A

Connecting terminal in terminal box POG 90

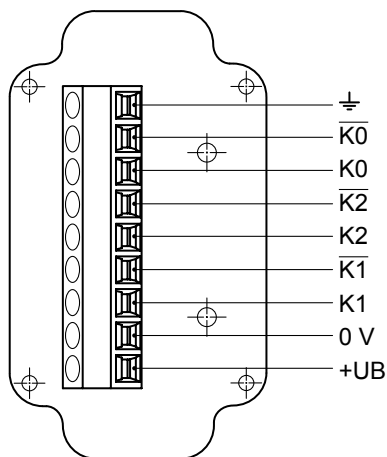

View B

Connecting terminal mechanical centrifugal switch FSL

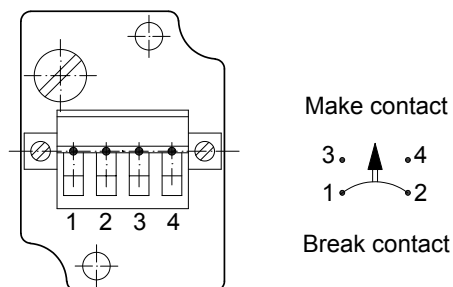

Combination

Encoder with integrated centrifugal switch

Solid shaft with EURO flange B10

1024...10000 pulses per revolution

POG 90 + FSL

Dimensions

