

Combination

Encoder with integrated electronic speed switch

Solid shaft with EURO flange B10

300...5000 pulses per revolution

POG 10 + ESL



POG 10 + ESL

Features

- TTL output driver for cable length up to 500 m
- Electronic speed monitoring
- Circuit breaker with up to three selectable threshold speeds
- EURO-flange B10 / solid shaft $\varnothing 11$ mm
- Terminal boxes, turn by 180°

Optional

- Function control with EMS (Enhanced Monitoring System)
- Redundant sensing with two terminal boxes
- Housing foot (B3)

Technical data - electrical ratings (encoder)

Voltage supply	9...30 VDC; 5 VDC ± 5 %
Consumption w/o load	≤ 100 mA
Pulses per revolution	300...5000
Phase shift	$90^\circ \pm 20^\circ$
Scan ratio	40...60 %
Reference signal	Zero pulse, width 90°
Output frequency	≤ 120 kHz ≤ 300 kHz (on request)
Output signals	K1, K2, K0 + inverted Error output (only EMS)
Output stages	HTL-P (power linedriver) TTL/RS422
Sensing method	Optical

Technical data - electrical ratings (speed switches)

Switching accuracy	± 4 % (≤ 1500 rpm) ± 2 % (> 1500 rpm)
Switching hysteresis	≈ 30 % of switching speed
Switching delay time	≤ 40 ms

POG 10 + ESL 90

Switching outputs	1 output, speed control
Output switching capacity	≤ 6 A / 250 VAC; ≤ 1 A / 48 VDC
Minimum switching current	100 mA

POG 10 + ESL 93

Voltage supply	12 VDC ± 10 %
Consumption w/o load	≤ 5 mA
Switching outputs	3 outputs, speed control
Current each output	40 mA

Technical data - mechanical design

Size (flange)	$\varnothing 115$ mm
Shaft type	$\varnothing 11$ mm solid shaft
Admitted shaft load	≤ 300 N axial ≤ 450 N radial
Flange	EURO flange B10
Protection DIN EN 60529	IP 66
Operating torque typ.	3 Ncm
Rotor moment of inertia	220 gcm ²
Materials	Housing: aluminium die-cast Shaft: stainless steel
Operating temperature	$-20...+85$ °C
Resistance	IEC 60068-2-6 Vibration 10 g, 10-2000 Hz IEC 60068-2-27 Shock 100 g, 11 ms
Corrosion protection	IEC 60068-2-52 Salt mist Complies to ISO 12944-5:1998 Protective paint systems (C4)
Connection	2x terminal box 3x terminal box (with option M)
Weight approx.	2.7 kg, 2.9 kg (with option M)
Interference immunity	EN 61000-6-2
Emitted interference	EN 61000-6-3
Approval	CE
POG 10 + ESL 90	
Operating speed	≤ 6000 rpm
Range of switching speed (ns)	650...6000 rpm
POG 10 + ESL 93	
Operating speed	≤ 5000 rpm
Range of switching speed (ns)	3x 200...5000 rpm

Combination

Encoder with integrated electronic speed switch

Solid shaft with EURO flange B10

300...5000 pulses per revolution

POG 10 + ESL

Output signals

At positive rotating direction

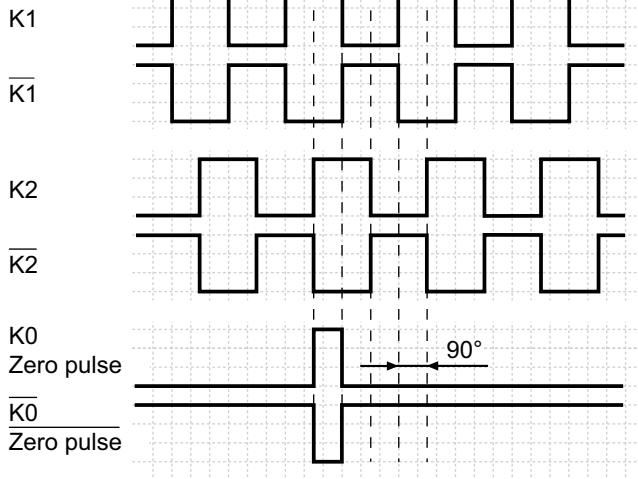

Option EMS: LED status / Error output

Flash light red*	Error of signal sequence, zero pulse or pulses (Error output = HIGH-LOW alternation)
Red	Overload output driver (Error output = LOW)
Flash light green	Encoder o.k., rotating (Error output = HIGH)
Green	Encoder o.k., stopped (Error output = HIGH)
No light	No output voltage connection or wrong connection (Error output = LOW)

* Only at rotating encoder

Terminal assignment

View A

Connecting terminal in terminal box POG 10

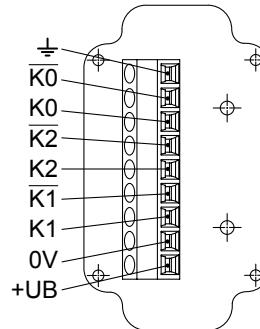

Option EMS: View A

Connecting terminal in terminal box POG 10.2

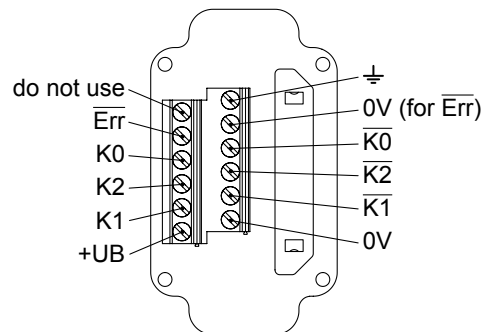

View B

Connecting terminal electronic speed switch ESL 90

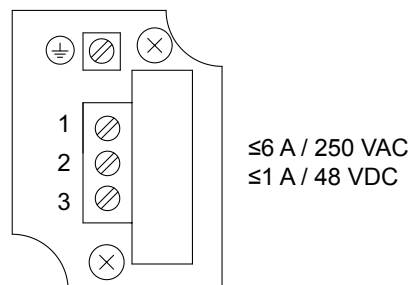

View B

Connecting terminal electronic speed switch ESL 93

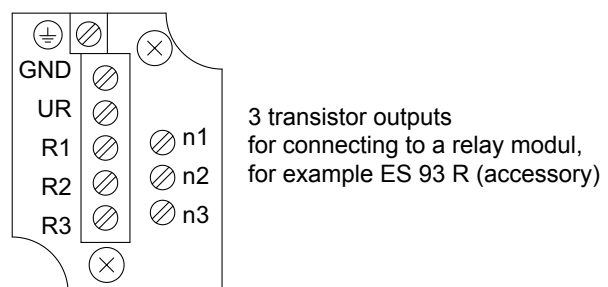

Combination

Encoder with integrated electronic speed switch

Solid shaft with EURO flange B10

300...5000 pulses per revolution

POG 10 + ESL

Block circuit diagram

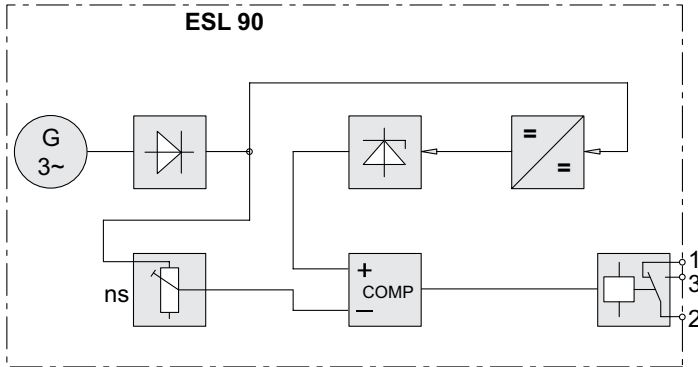

Switching characteristics

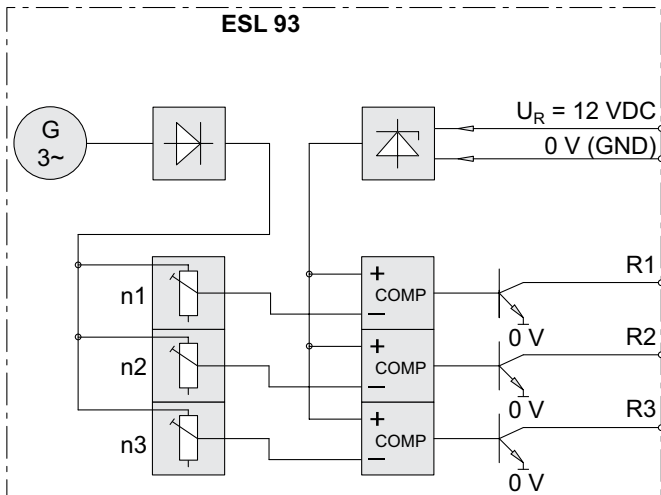
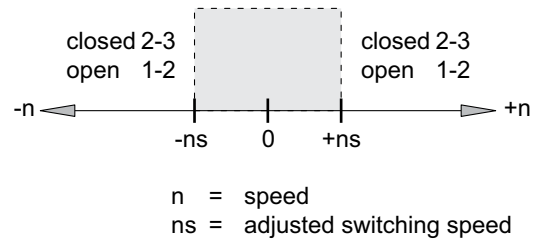

Recommended output circuit

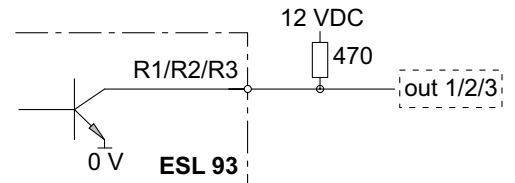

Switching characteristics

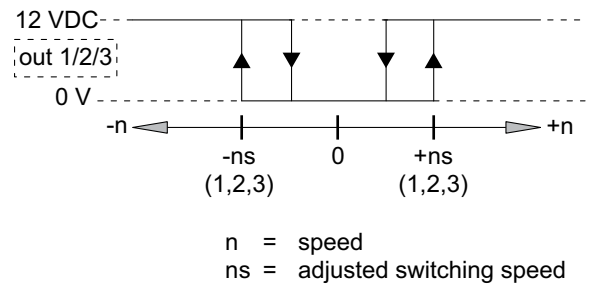

Combination

Encoder with integrated electronic speed switch
 Solid shaft with EURO flange B10
 300...5000 pulses per revolution

POG 10 + ESL

Dimensions

POG 10 + ESL (POG 10.2 + ESL, POG 10 M + ESL, POG 10.2 M + ESL) - Version with B10 Euro flange

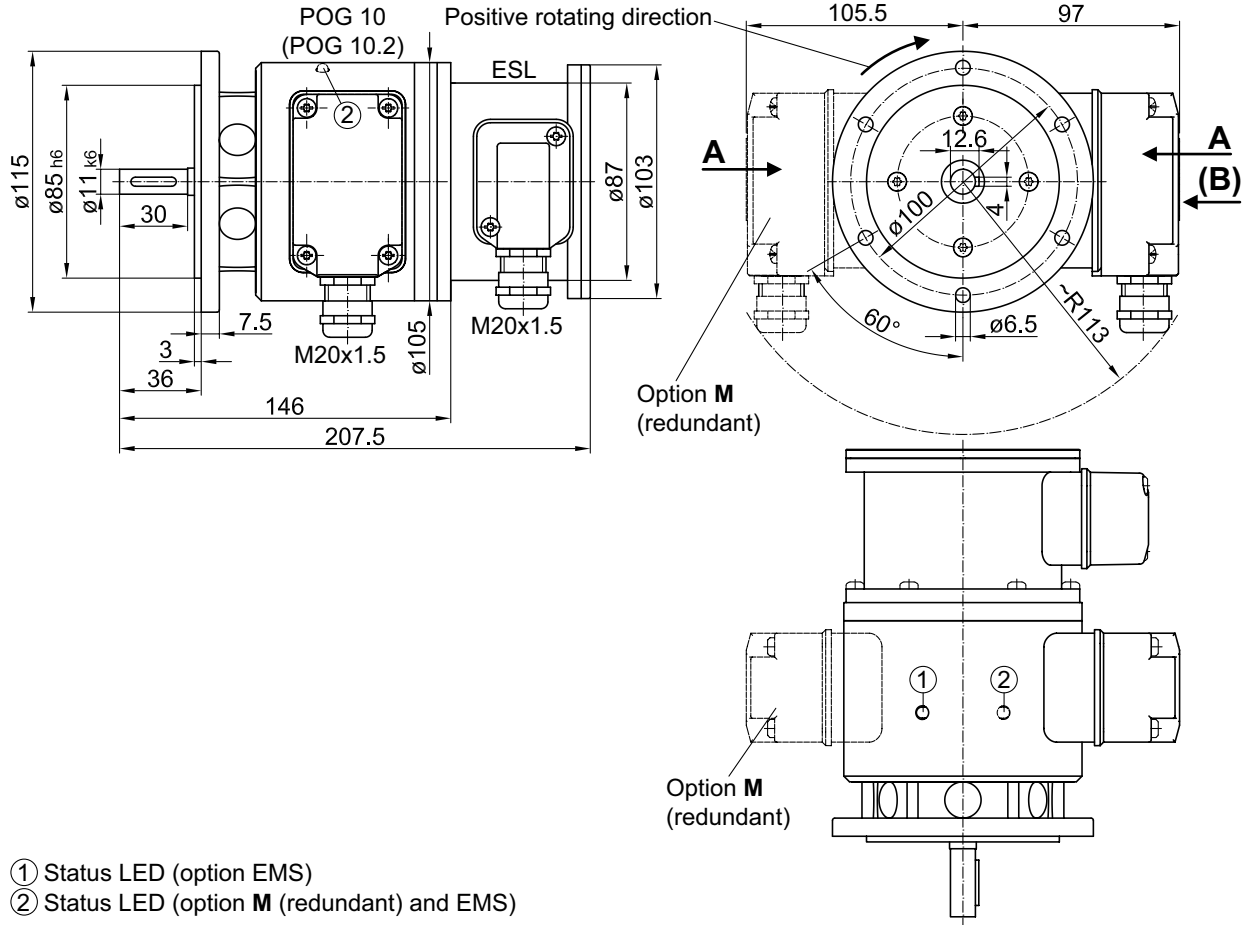

POG 10 + ESL - Version with housing foot

