

# Combination

Twin encoder with two electrically separated systems

Solid shaft with EURO flange B10

300...5000 pulses per revolution

## POG 11 G



POG 11 G

### Technical data - electrical ratings

Voltage supply	9...30 VDC 5 VDC $\pm$ 5 %
Consumption w/o load	$\leq$ 100 mA
Pulses per revolution	300...5000
Phase shift	90° $\pm$ 20°
Scan ratio	40...60 %
Reference signal	Zero pulse, width 90°
Output frequency	$\leq$ 120 kHz $\leq$ 300 kHz (on request)
Output signals	K1, K2, K0 + inverted Error output (only EMS)
Output stages	HTL-P (power linedriver) TTL/RS422
Sensing method	Optical
Interference immunity	EN 61000-6-2
Emitted interference	EN 61000-6-3
Approvals	CE, UL approval / E256710

### Features

- Twin encoder featuring two separate systems
- Offshore and salt water firm, high protection IP 67
- TTL output driver for cable length up to 500 m
- Very high resistance to shock and vibrations
- EURO-flange B10 / solid shaft  $\varnothing$ 11 mm
- Large terminal boxes, turn by 180°

### Optional

- Function control with EMS  
(Enhanced Monitoring System)
- Redundant sensing with two terminal boxes
- Housing foot (B3)

### Technical data - mechanical design

Size (flange)	$\varnothing$ 115 mm
Shaft type	$\varnothing$ 11 mm solid shaft
Admitted shaft load	$\leq$ 300 N axial $\leq$ 450 N radial
Flange	EURO flange B10
Protection DIN EN 60529	IP 67
Operating speed	$\leq$ 12000 rpm (mechanical)
Operating torque typ.	2 Ncm
Rotor moment of inertia	200 gcm <sup>2</sup>
Materials	Housing: aluminium die-cast Shaft: stainless steel
Operating temperature	-40...+100 °C -25...+100 °C (>3072 pulses per revolution)
Resistance	IEC 60068-2-6 Vibration 25 g, 10-2000 Hz IEC 60068-2-27 Shock 300 g, 6 ms
Corrosion protection	IEC 60068-2-52 Salt mist Complies to ISO 12944-5:1998 Protective paint systems (C5-M)
Explosion protection	II 3 G Ex nA IIC T4 Gc (gas) II 3 D Ex tc IIIC T135°C Dc (dust)
Connection	2x terminal box 3x terminal box (with option M)
Weight approx.	2.5 kg, 2.7 kg (with option M)

# Combination

Twin encoder with two electrically separated systems

Solid shaft with EURO flange B10

300...5000 pulses per revolution

POG 11 G

## Part number

### Incremental encoder

POG11 

	G			DN				/	DN				
--	---	--	--	----	--	--	--	---	----	--	--	--	--

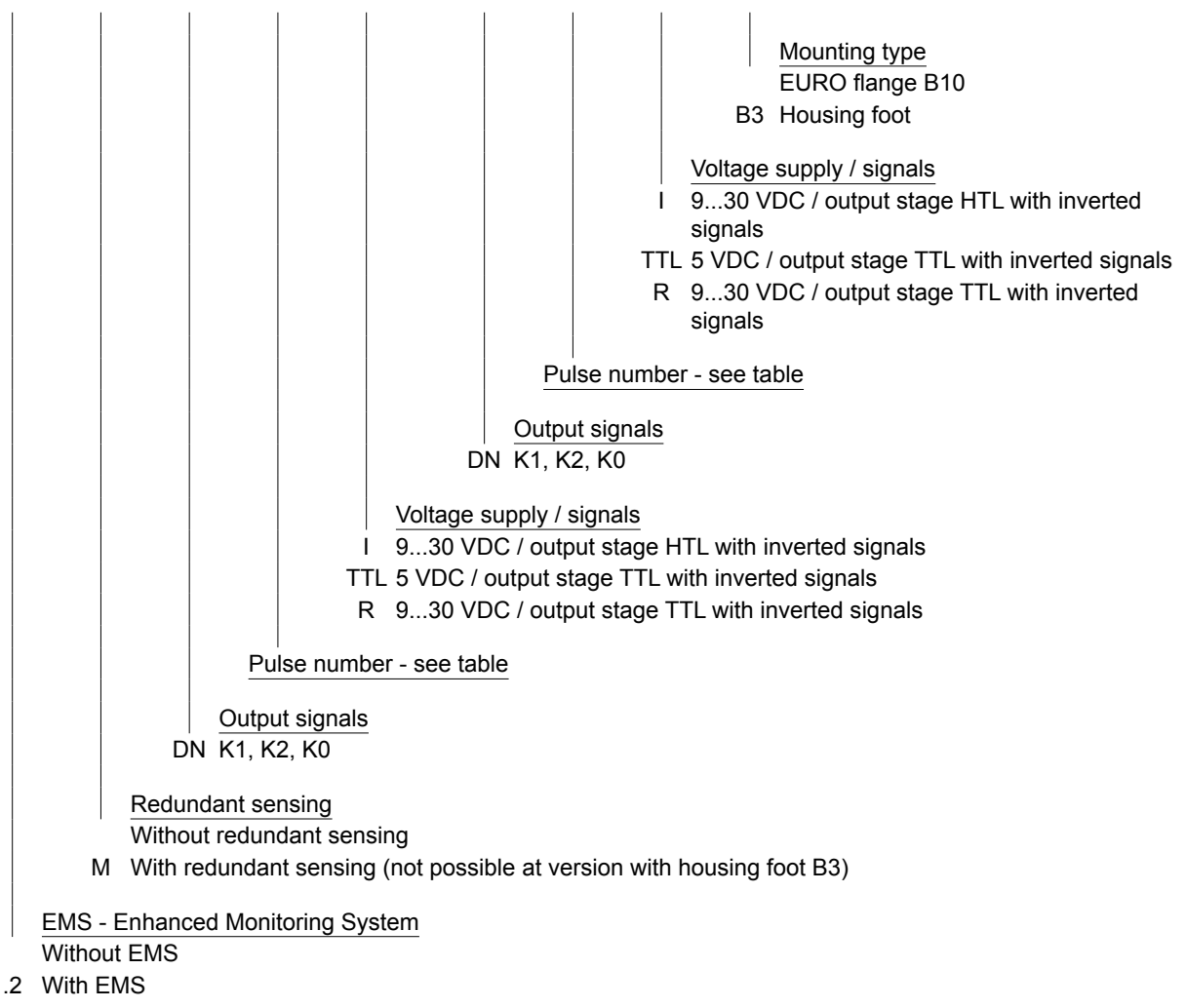

## Pulse number

300	1000	2048	4096
500	1024	2500	5000
512	1200	3072	

Other pulse numbers on request.

# Combination

Twin encoder with two electrically separated systems

Solid shaft with EURO flange B10

300...5000 pulses per revolution

## POG 11 G

### Output signals

At positive rotating direction

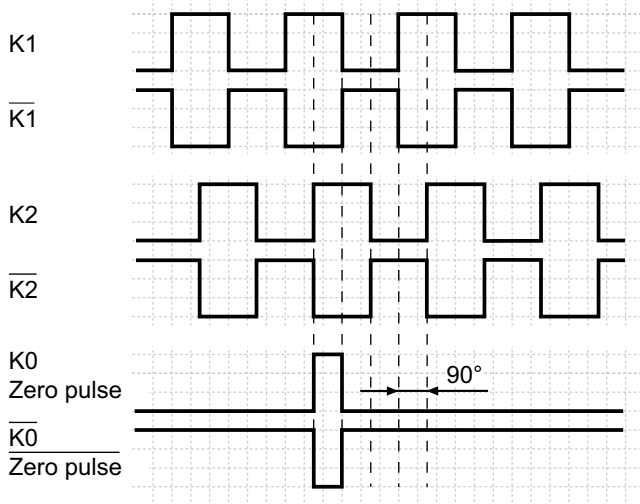

### Option EMS: LED status / Error output

Flash light red*	Error of signal sequence, zero pulse or pulses (Error output = HIGH-LOW alternation)
Red	Overload output driver (Error output = LOW)
Flash light green	Encoder o.k., rotating (Error output = HIGH)
Green	Encoder o.k., stopped (Error output = HIGH)
No light	No output voltage connection or wrong connection (Error output = LOW)

\* Only at rotating encoder

### Terminal assignment

#### View A

Connecting terminal in terminal box

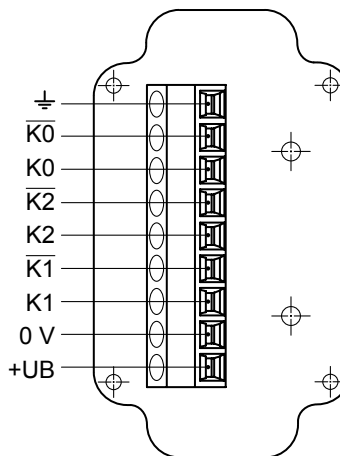

#### Option EMS: View A

Connecting terminal in terminal box

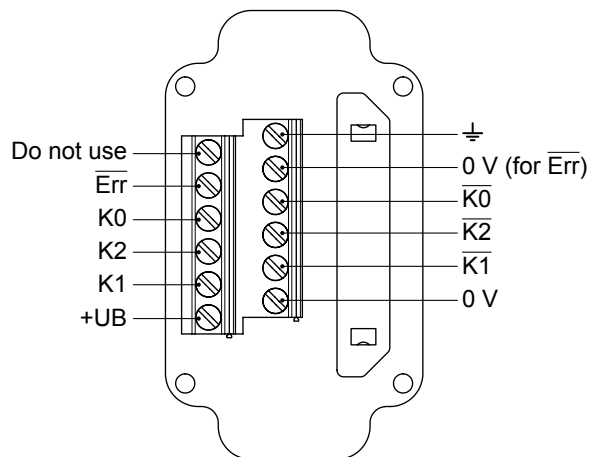

### Option EMS: LED status / Error output

Flash light red*	Error of signal sequence, zero pulse or pulses (Error output = HIGH-LOW alternation)
Red	Overload output driver (Error output = LOW)
Flash light green	Encoder o.k., rotating (Error output = HIGH)
Green	Encoder o.k., stopped (Error output = HIGH)
No light	No output voltage connection or wrong connection (Error output = LOW)

\* Only at rotating encoder

---

## Accessories

### Connectors and cables

HEK 8	Sensor cable for encoders
-------	---------------------------

### Mounting accessories

Spring washer K 35, shaft $\varnothing 6 \dots 12$ mm	Spring washer coupling for solid shaft $\varnothing 6 \dots 12$ mm
---	--

Spring washer K 50, shaft $\varnothing 11 \dots 16$ mm	Spring washer coupling for solid shaft $\varnothing 11 \dots 16$ mm
--	---

Spring washer K 60, shaft $\varnothing 11 \dots 22$ mm	Spring washer coupling for solid shaft $\varnothing 11 \dots 22$ mm
--	---

### Diagnostic accessories

11075858	Analyzer for encoders HENQ 1100
----------	---------------------------------

---

# Combination

Twin encoder with two electrically separated systems  
 Solid shaft with EURO flange B10  
 300...5000 pulses per revolution

POG 11 G

## Dimensions

POG 11 G (POG 11.2 G, POG 11 G M, POG 11.2 G M) - Version with Euro flange (B10)

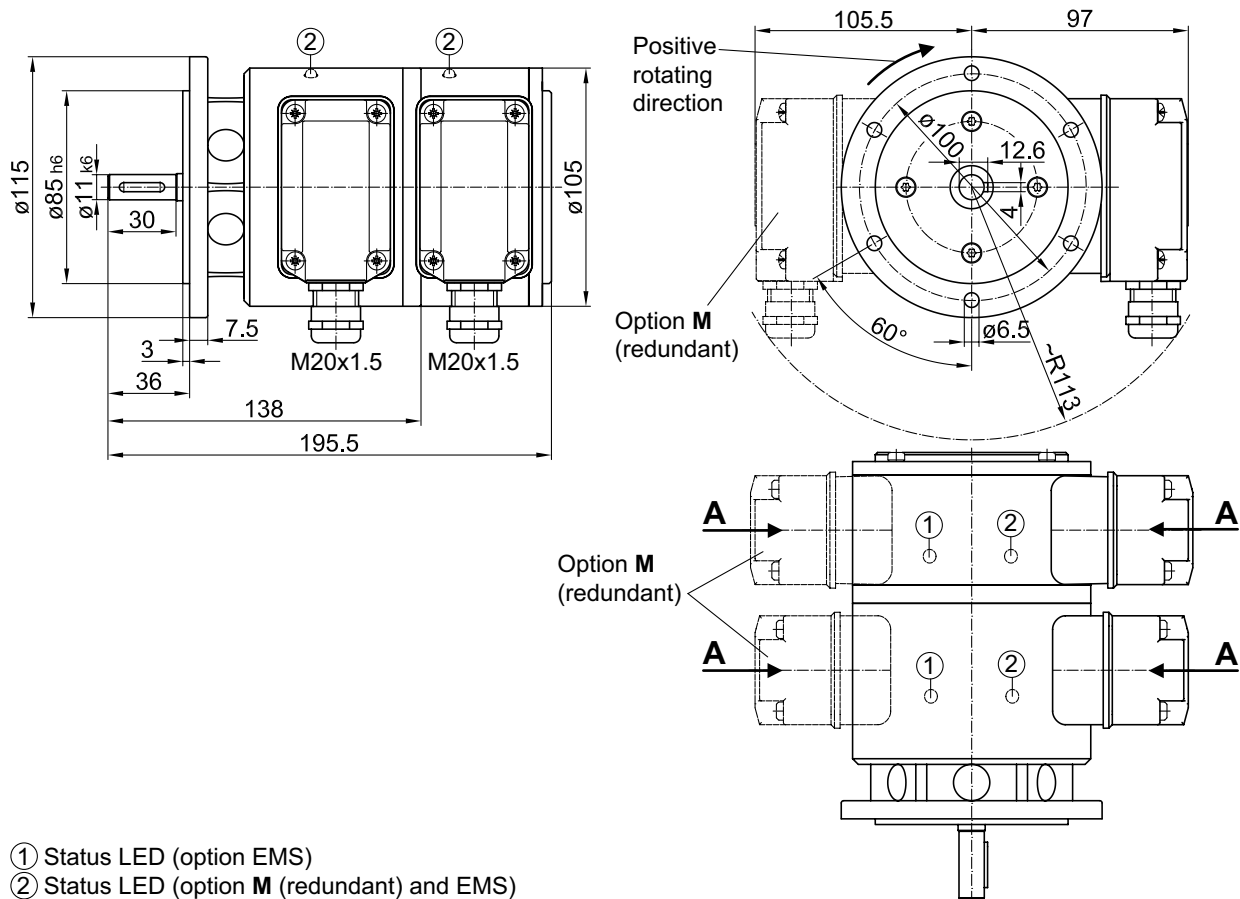

POG 11 G - Version with housing foot (B3)

