

Encoders without bearings - incremental

Combination of sensor / magnetic wheel

Max. 1024 pulses per revolution

MDFK 08



MDFK 08

Features

- Magnetic sensor with magnetic wheel
- Resolution max. 4096 steps
- Output signals A 90° B or A 90° B +N
- Output circuits: push-pull and RS422
- Non-contact, wear-free sensing system
- High resistance to dirt
- Narrow mounting design

Technical data - electrical ratings

Pulses per revolution	256...1024
Interpolation	8-fold, 16-fold
Reference signal	Zero pulse, width 90°
Output frequency	≤1.6 MHz (8-fold interpolation) ≤3.2 MHz (16-fold interpolation)
System accuracy	±0.5°
Jitter	≤15 %

MDFK 08G

Voltage supply	8...30 VDC
Consumption w/o load	≤30 mA
Switching current max.	50 mA
Output stages	Push-pull short-circuit proof
Output signals	A 90° B A 90° B, 0
Reverse polarity protection	Yes, to GND
Voltage drop	<2 VDC (I=20 mA)

MDFK 08T

Voltage supply	5 VDC ±5 %
Consumption w/o load	≤15 mA
Switching current max.	RS422 specific
Output stages	RS422
Output signals	A 90° B + inverted A 90° B, N + inverted
Reverse polarity protection	No
Voltage drop	RS422 specific

Technical data - mechanical design

Dimensions W x H x L	15 x 8.5 x 45.5 mm
Shaft type	∅6...43.5 mm (through hollow shaft)
Protection DIN EN 60529	IP 67
Operating temperature	-25...+85 °C
Working distance	<0.6 mm
Fastening torque	0.4 Nm
Resistance	DIN EN 60068-2-6 Vibration 20 g, 10-2000 Hz DIN EN 60068-2-27 Shock 100 g, 6 ms
Material	Housing: PC
Relative humidity	95 %
Connection	Cable 2 m
Weight approx.	105 g

Encoders without bearings - incremental

Combination of sensor / magnetic wheel

Max. 1024 pulses per revolution

MDFK 08

Part number

Sensor head - Push-pull

MDFK 08G <input type="text"/>	
	<u>Interface / Interpolation</u>
2101	A/B / 8-fold
2124/N16	A/B / 16-fold
8124/N8	A/B/N / 8-fold
8124	A/B/N / 16-fold

Sensor head - RS422

MDFK 08T <input type="text"/>	
	<u>Interface / Interpolation</u>
7101	A/B + inv. / 8-fold
7105/N16	A/B + inv. / 16-fold
8101	A/B/N + inv. / 8-fold
8105/N16	A/B/N + inv. / 16-fold

Magnetic wheel

MIR10-P. <input type="text"/>	.	<input type="text"/>	<input type="text"/>	S
				<u>Bore diameter*</u>
				006 ø6 mm
				5Z8 ø5/8" (15.875 mm)
				025 ø25 mm
				1Z0 ø1" (25.4 mm)
				<u>Reference</u>
				N Without reference magnet
				A With reference magnet
				<u>Number of poles</u>
032.0.031				32 poles (Bore diameter max. 17.5 mm)
036.0.031				36 poles (Bore diameter max. 17.5 mm)
050.0.056				50 poles (Bore diameter max. 43.5 mm)
064.0.056				64 poles (Bore diameter max. 43.5 mm)

* Other bore diameter on request.

Selection of sensor head / magnetic wheel

The pulses are a result of the interpolation factor of the sensor head and the number of poles on the magnetic wheel. The table below shows as an example which sensor head and which magnetic wheel have to be combined in order to achieve a certain number of pulses. Other pulses are available on request.

Sensor head MDFK 08 Interpolation factor	Magnetic wheel MIR10-P			
	32 poles	36 poles	50 poles	64 poles
8	256	288	400	512
16	512	576	800	1024

Encoders without bearings - incremental

Combination of sensor / magnetic wheel

Max. 1024 pulses per revolution

MDFK 08

Accessories

Mounting accessories

10134683 Mounting angle for MDFK08 3-channel

Output signals

push-pull

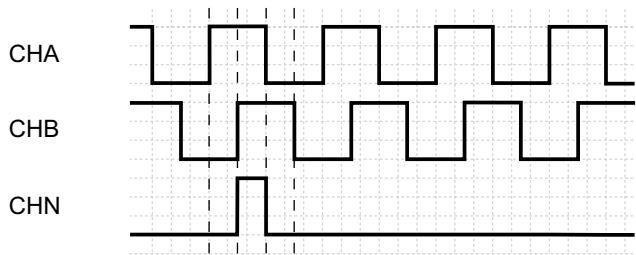

3-channel version with zero-pulse (CHN)
2-channel version without zero-pulse

RS422

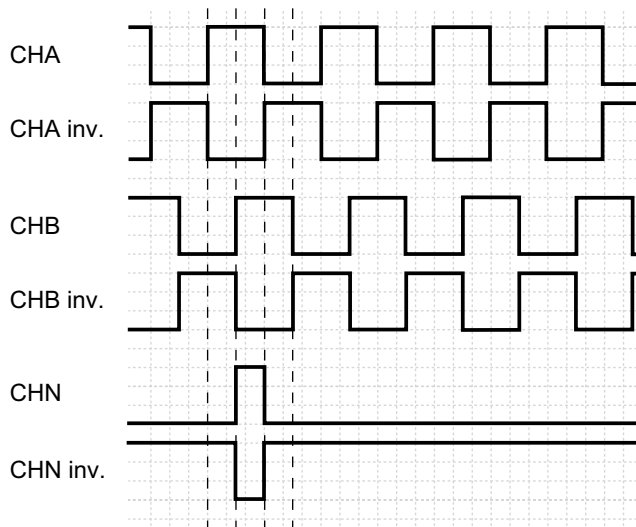

3-channel-version with zero-pulse (CHN/CHN inv.)
3-channel-version with zero-pulse

Rotational or linear direction

2-channel

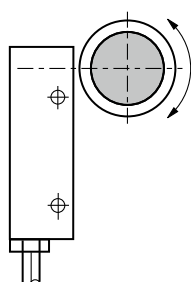

3-channel

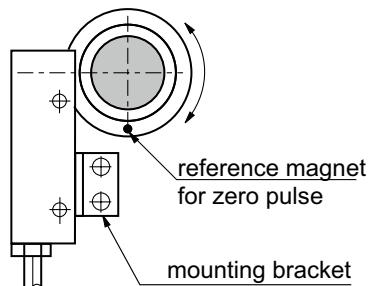

CHA is leading CHB by 90° when rotating CW

Terminal assignment

Push-pull A 90° B (2-channel)

cable color		signals
brown	BN	+Vs
blue	BU	0 V
black	BK	CHA
white	WH	CHB

cable data PUR 4 x 0.25 mm²

Push-pull A 90° B, N (3-channel)

cable color		signals
brown	BN	+Vs
yellow	YE	CHB
green	GN	CHA
pink	PK	CHN
white	WH	0 V

cable data PUR 5 x 0.14 mm², shielded

RS422 A 90° B + inv. (2-channel)

cable color		signals
brown	BN	+Vs
green	GN	CHA
pink	PK	CHA inv.
yellow	YE	CHB
gray	GY	CHB inv.
white	WH	0 V

cable data PUR 6 x 0.14 mm²

RS422 A 90° B, N + inv. (3-channel)

cable color		signals
brown	BN	+Vs
green	GN	CHA
red	RD	CHA inv.
yellow	YE	CHB
blue	BU	CHB inv.
pink	PK	CHN
gray	GY	CHN inv.
white	WH	0 V

cable data PUR 8 x 0.14 mm², shielded

Encoders without bearings - incremental

Combination of sensor / magnetic wheel

Max. 1024 pulses per revolution

MDFK 08

Axial misalignment

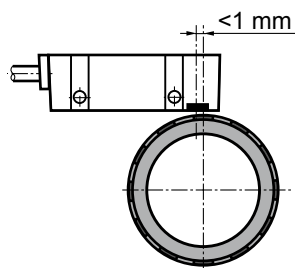

Working distance

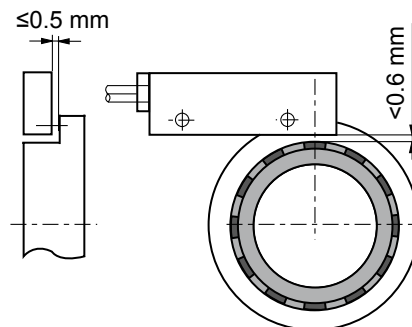

Angular misalignment

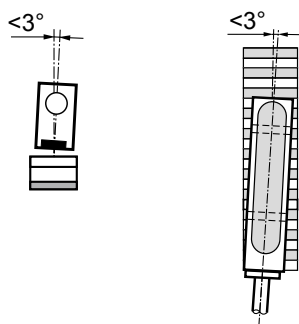

Dimensions

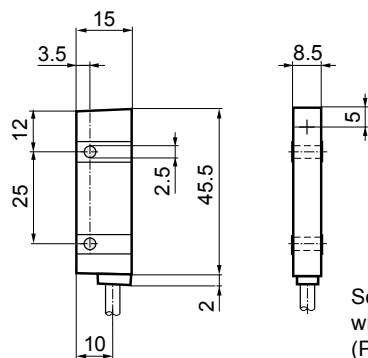

Sensor can also be mounted with self-tapping special screws (PT KA30)

Encoders without bearings - incremental

Combination of sensor / magnetic wheel

Max. 1024 pulses per revolution

MDFK 08

Magnetic wheel without reference magnet

MIR10-P with 32, 36 poles

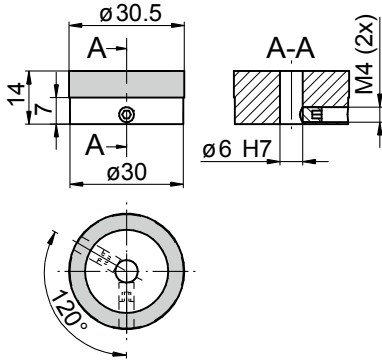

MIR10-P with 50, 64 poles

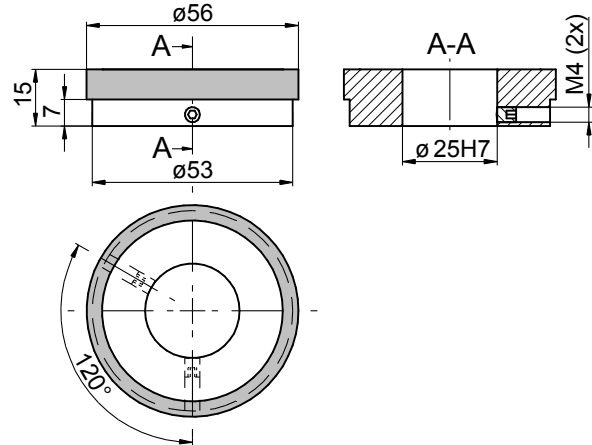

Magnetic wheel with reference magnet

MIR10-P with 32, 36 poles

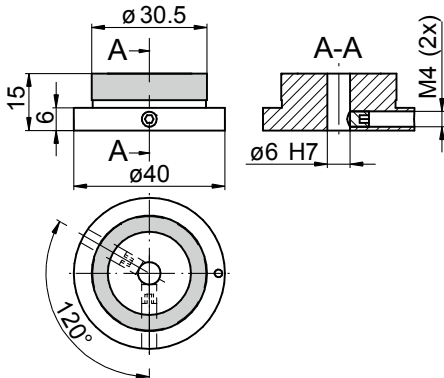

MIR10-P with 50, 64 poles

