

Encoders without bearings - incremental

Sensor head with integrated FPGA signal processing, magnetic sensing

128...262144 pulses or 128...16384 sinewave cycles per turn

Through hollow shaft max. \varnothing 180 mm

MHGP 200 - HDmag

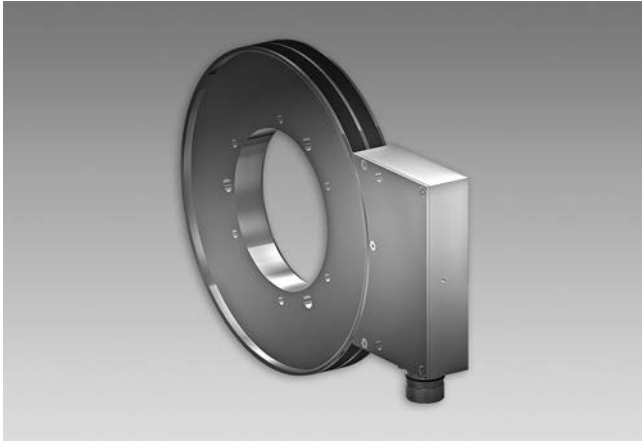

MHGP 200 - Version for axial screw mounting

Features

- Sinewave or square-wave signals
- Robust and wearless
- Electronics is fully encapsulated, high protection
- Large tolerances: axial ± 3 mm, radial max. 2.2 mm
- Very compact dimensions
- Simple mounting, easy adaptation
- Several mounting possibilities
- Sensor head with integrated FPGA signal processing

Optional

- Triple-bandage (increased operating speed)

Technical data - electrical ratings

Interference immunity	EN 61000-6-2
Emitted interference	EN 61000-6-3
Approval	CE

Technical data - electrical ratings (square-wave)

Voltage supply	4.5...30 VDC
Consumption w/o load	≤ 160 mA
Pulses per revolution	128...262144
Phase shift	$90^\circ \pm 10^\circ$
Scan ratio	40...60 %
Reference signal	Zero pulse, width 90°
Sensing method	Magnetic
Output frequency	≤ 2 MHz
Output signals	A+, B+, R+, A-, B-, R-
Output stages	HTL TTL/RS422

Technical data - electrical ratings (SinCos)

Voltage supply	4.5...30 VDC
Consumption w/o load	≤ 160 mA
Sinewave cycles per turn	128...16384
Phase shift	$90^\circ \pm 5^\circ$
Reference signal	Zero pulse, width 90°
Sensing method	Magnetic
Output signals	A+, B+, R+, A-, B-, R-
Output stages	SinCos 1 Vpp
Difference of SinCos amplitude	≤ 20 mV
Harmonics typ.	-40 dB
DC offset	≤ 20 mV
Bandwidth	400 kHz (-3 dB)

Technical data - mechanical design

Sensor head	FPGA signal processing
Size (flange)	$\varnothing 201.7$ mm
Shaft type	$\varnothing 50...180$ mm (through hollow shaft)
Axial tolerance	± 3 mm (wheel/head)
Radial tolerance	0.1...2.2 mm (wheel/head)
Protection DIN EN 60529	IP 67 (head), IP 68 (wheel)
Operating temperature	$-20...+85$ °C
Operating speed	≤ 4000 rpm
Resistance	IEC 60068-2-6 Vibration 30 g, 55-2000 Hz IEC 60068-2-27 Shock 300 g, 2 ms
Accuracy of magnetic measure	± 150 "
Connection	Flange connector M23, 12-pin

Encoders without bearings - incremental

Sensor head with integrated FPGA signal processing, magnetic sensing
128...262144 pulses or 128...16384 sinewave cycles per turn
Through hollow shaft max. ø180 mm

MHGP 200 - HDmag

Part number

MHGP 200 5 N C

|
Pulse number/sinewave cycles - see table

|
Voltage supply / signals

- P 4.5...30 VDC / SinCos
- R 4.5...30 VDC / square-wave (TTL)
- T 5 VDC ±5 % / square-wave (TTL)
- H 10...30 VDC / square-wave (HTL)
- U 5...30 VDC / square-wave (5 VDC = TTL / 10...30 VDC = HTL universal)

|
Mounting type / hollow shaft (ø mm)

- Screw or shrink fit mounting
G50, G75, G80, G85, G90, G95, G100, G110, G115, G120, G130, G150, G160, G170, G180
- Clamping set mounting
Z70, Z75, Z80, Z85, Z90, Z95, Z100, Z110, Z120, Z130, Z140, Z150
- Clamping ring mounting
K70, K75, K80, K85, K90, K95, K100, K105, K110, K115, K120, K130, K140, K150, K160

Bandaging

- B Encoder wheel standard bandage
- T Encoder wheel with triple-bandage

Pulse number/sinewave cycles

128	1024	8192	65536
256	2048	16384	131072
512	4096	32768	262144

Accessories

Connectors and cables

HEK 8	Sensor cable for encoders
-------	---------------------------

Maximum sinewave cycles 16384 for SinCos output.

Encoders without bearings - incremental

Sensor head with integrated FPGA signal processing, magnetic sensing

128...262144 pulses or 128...16384 sinewave cycles per turn

Through hollow shaft max. $\varnothing 180$ mm

MHGP 200 - HDmag

Output signals

Version with square-wave signals HTL oder TTL at positive rotating direction

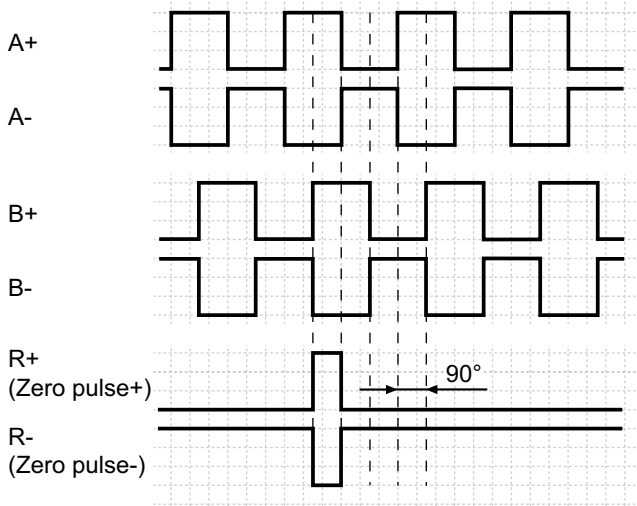

Version with SinCos signals at positive rotating direction

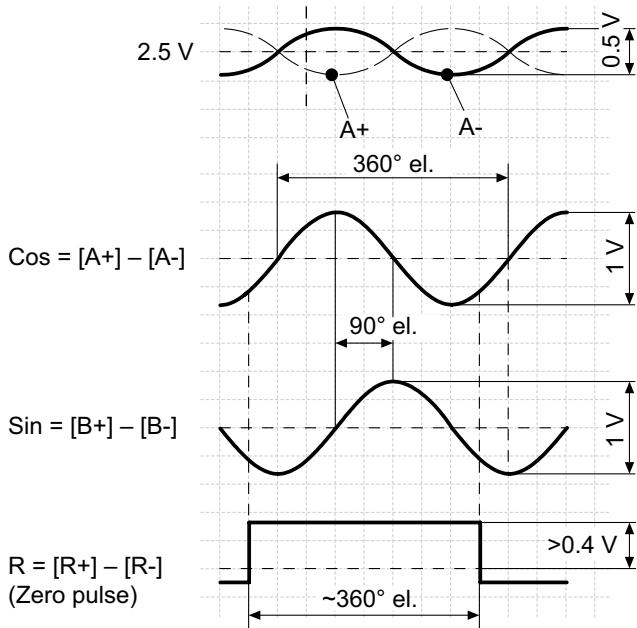

Terminal assignment

View A

Flange connector M23, 12-pin, male contacts, CCW

Pin	Assignment
1	B-
2	Do not use
3	R+ (Zero pulse)
4	R- (Zero pulse inv.)
5	A+
6	A-
7	Do not use
8	B+
9	Do not use
10	⊥
11	Do not use
12	+UB

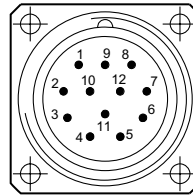

Encoders without bearings - incremental

Sensor head with integrated FPGA signal processing, magnetic sensing

128...262144 pulses or 128...16384 sinewave cycles per turn

Through hollow shaft max. $\varnothing 180$ mm

MHGP 200 - HDmag

Dimensions

Version for axial screw mounting or shrink fit mounting

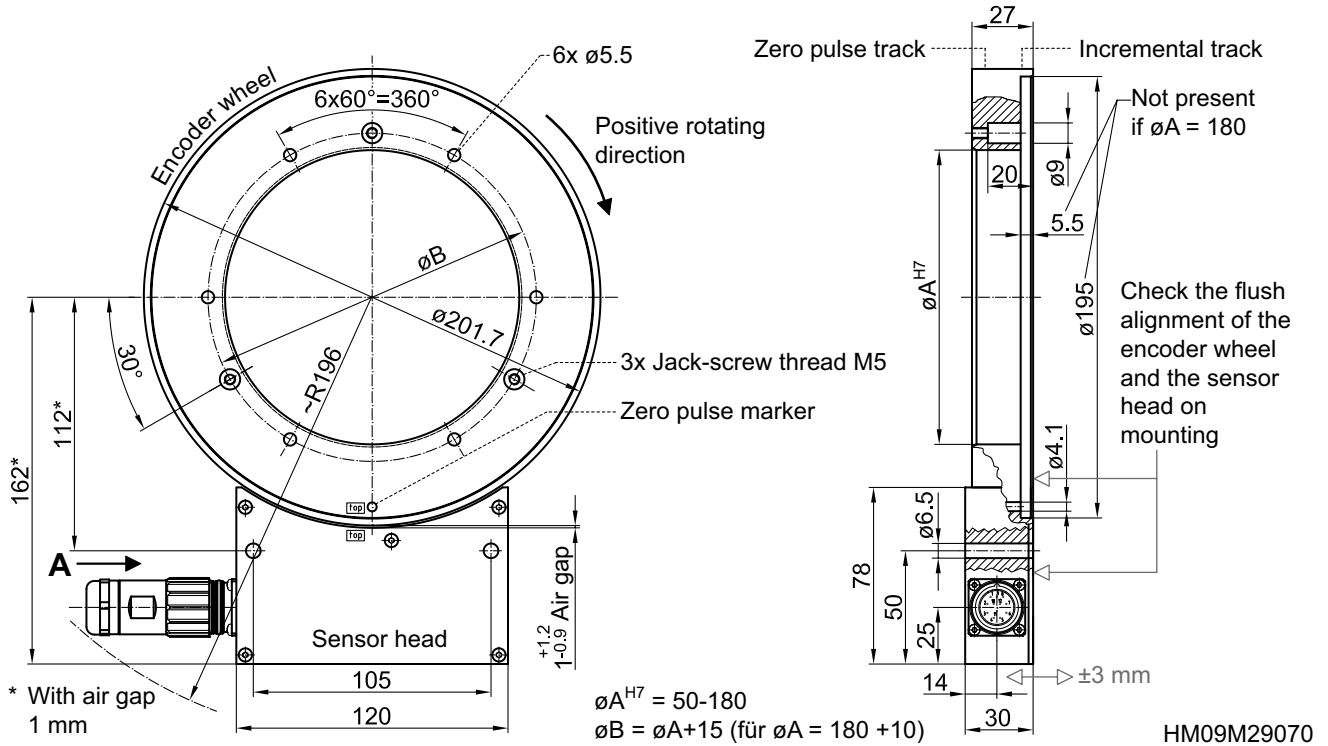

Version for clamping set mounting

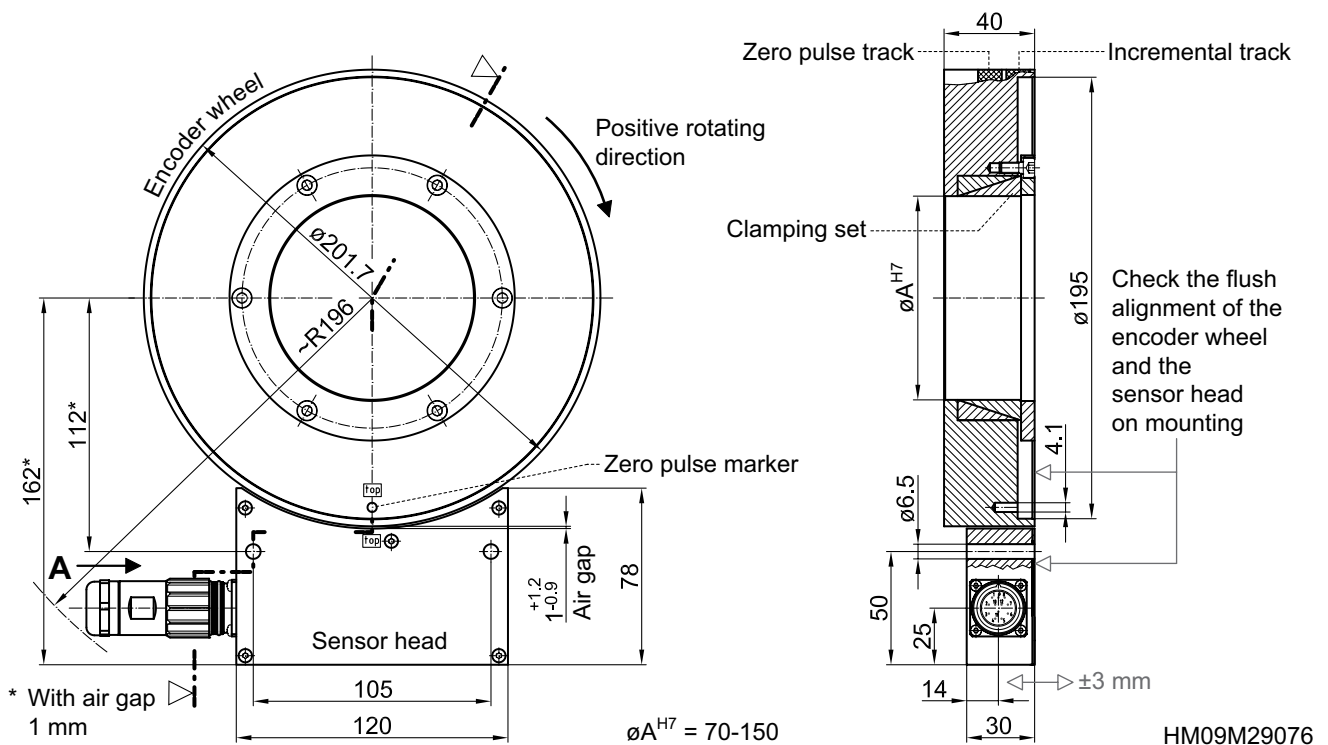

Encoders without bearings - incremental

Sensor head with integrated FPGA signal processing, magnetic sensing

128...262144 pulses or 128...16384 sinewave cycles per turn

Through hollow shaft max. $\varnothing 180$ mm

MHGP 200 - HDmag

Dimensions

Version for clamping ring mounting

