

Encoders without bearings - incremental

Incremental encoder with optical sensing

Through hollow shaft $\varnothing 20 \dots 45$ mm

250...2048 pulses per revolution

HG 16



Features

- Large axial and radial displacement of the shaft permitted
- Fit for high operating speed
- Robust and wearless
- Max. 2048 pulses per revolution
- Logic level TTL with regulator UB 9...26 VDC

Optional

- Electrical connection with flange connector and mating connector
- Redundant sensing (version M)

Technical data - electrical ratings

Voltage supply	9...30 VDC 5 VDC ± 5 % 9...26 VDC
Consumption w/o load	≤ 100 mA
Sensing method	Optical
Pulses per revolution	250...2048
Output stages	HTL TTL/RS422
Output signals	K1, K2, K0 + inverted
Reference signal	Zero pulse, width 90°
Output frequency	≤ 120 kHz
Phase shift	90° ± 20 °
Scan ratio	40...60 %
Interference immunity	EN 61000-6-2
Emitted interference	EN 61000-6-3
Approvals	CE, UL approval / E256710

Technical data - mechanical design

Size (flange)	$\varnothing 158$ mm
Shaft type	$\varnothing 20 \dots 45$ mm (through hollow shaft)
Axial tolerance	-0.5...1.5 mm (with zero pulse) -0.5...2.5 mm (without zero pulse)
Radial tolerance	± 0.05 mm (with zero pulse) ± 0.2 mm (without zero pulse)
Protection DIN EN 60529	IP 56 (≤ 9000 U/min), IP 54 (≤ 12000 rpm), IP 23 (≤ 30000 rpm)
Operating temperature	-30...+100 °C
Operating speed	≤ 9000 rpm (IP 56) ≤ 12000 rpm (IP 54) ≤ 30000 rpm (IP 23)
Operating torque typ.	1 Nm
Rotor moment of inertia	8.5 kgcm ²
Resistance	IEC 60068-2-6 Vibration 10 g, 10-2000 Hz IEC 60068-2-27 Shock 100 g, 6 ms
Materials	Housing: aluminium Shaft: stainless steel
Connection	Terminal box (2x with option M) Flange connector M23, 12-pin (2x with option M)
Weight approx.	2.4 kg

Encoders without bearings - incremental

Incremental encoder with optical sensing

Through hollow shaft $\varnothing 20...45$ mm

250...2048 pulses per revolution

HG 16

Part number

HG 16

--	--	--	--	--	--	--

				Voltage supply / signals - 9...30 VDC / output stage HTL I 9...30 VDC / output stage HTL with inverted signals TTL 5 VDC / output stage TTL with inverted signals R 9...26 VDC / output stage TTL with inverted signals (for output signals DN)
				Pulse number - see table
				Output signals
				D K1, K2
				DN K1, K2, K0
				Redundant sensing
				Without redundant sensing
				M With redundant sensing

Accessories

Eccentric disks
(clamping claws)

Connectors and cables

HEK 8 Sensor cable for encoders

Diagnostic accessories

HENQ 1100 Analyzer for encoders

Pulse number

250	512	1000	1080	2048
500	600	1024	1200	

Other pulse numbers on request.

Encoders without bearings - incremental

Incremental encoder with optical sensing

Through hollow shaft $\varnothing 20 \dots 45$ mm

250...2048 pulses per revolution

HG 16

Output signals

At positive rotating direction

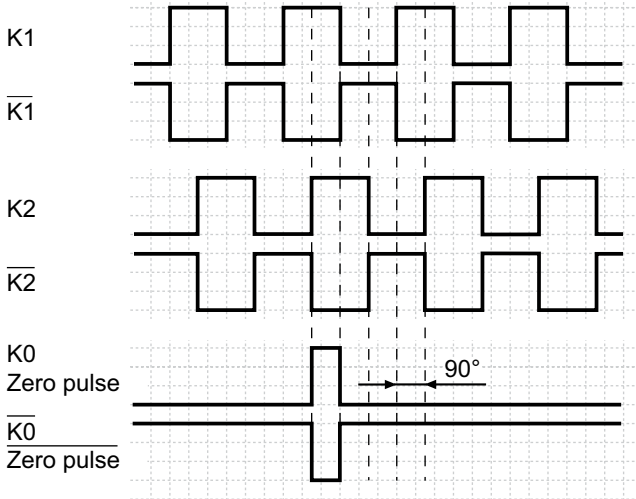

Terminal assignment

View A - Connecting terminal in terminal box

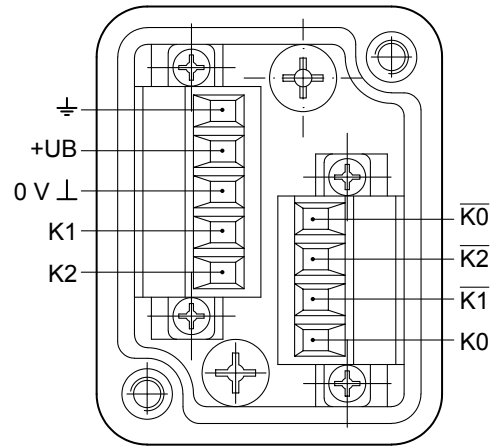

View B - Option: Flange connector M23, 12 pin, male contacts, CW

Pin	Assignment
1	$\overline{K2}$ (K2 inv.)
2	Do not use
3	K0 (Zero pulse)
4	$\overline{K0}$ (Zero pulse inv.)
5	K1
6	$\overline{K1}$ (K1 inv.)
7	Do not use
8	K2
9	Do not use
10	0 V
11	Do not use
12	+UB

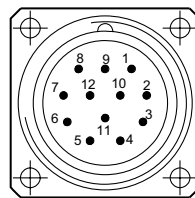

Encoders without bearings - incremental

Incremental encoder with optical sensing

Through hollow shaft $\varnothing 20\text{...}45\text{ mm}$

250...2048 pulses per revolution

HG 16

Dimensions

