

Retro-reflective sensors

FPDH 14P5101

dimension drawing

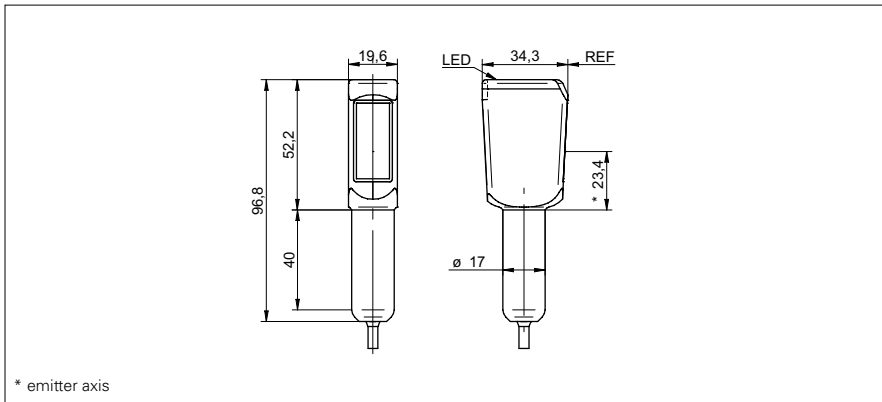

* emitter axis

general data

type	retro-reflective sensor
special type	hygienic design
light source	pulsed red LED
actual range S_b	3 m
nominal range S_n	3,5 m
polarization filter	yes
alignment / soiled lens indicator	flashing light indicator
light indicator	LED yellow
sensitivity adjustment	no
wave length	660 nm
suppression of reciprocal influence	yes
approvals/certificates	Ecolab EHEDG

photo



electrical data

response time / release time	< 1 ms
voltage supply range +Vs	10 ... 30 VDC
current consumption max. (no load)	25 mA
current consumption typ.	20 mA
voltage drop Vd	< 1,8 VDC
output function	light / dark operate
output circuit	PNP
output current	< 100 mA
short circuit protection	yes
reverse polarity protection	yes

connection diagram

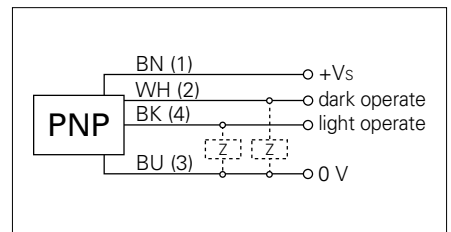

proTect⁺



- Sensor FDA compliant, EHEDG certified and Ecolab approved

Retro-reflective sensors**FPDH 14P5101****ambient conditions**

operating temperature	-30 ... +60 °C
protection class	IP 68/69K & proTect+
storage temperature	-30 ... +70 °C