

US-P | PG thread

Metal connector, safety-type, straight, PG outer thread, incl. ferrule [brass | plastics], sealing [TPE] and O-ring [NBR]

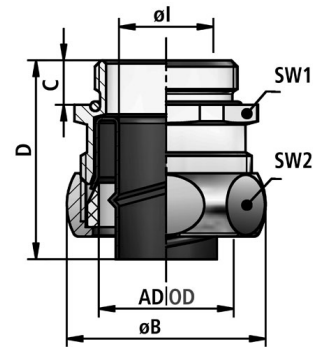

Temperature: -40°C ... +125°C

Material: nickel-plated brass

Protection class [acc. to EN 60529]: IP00



FLEXA No.	OD [mm]	Thread type	Conduit DI	Conduit OD	ø 1 [mm]	ø B [mm]	C [mm]	D [mm]	WS1 [mm]	WS2 [mm]	Weight [kg/100]	PU [pcs.]
15010127007	10,0	PG7	8,0	10,0	6,5	19,0	7,0	28,0	15	17	1,420	50
15010127009	14,0	PG9	11,0	14,0	10,0	23,0	7,0	30,0	19	21	2,140	50
15010127011	17,0	PG11	14,0	17,0	12,5	27,0	7,0	30,0	23	25	3,000	50
15010127013	19,0	PG13,5	16,0	19,0	14,5	29,0	7,0	30,0	25	27	3,370	50
15010127016	21,0	PG16	18,0	21,0	16,5	31,0	7,0	30,0	27	29	3,700	50
15010127021	27,0	PG21	23,0	27,0	21,5	39,0	10,0	40,0	34	36	7,350	25
15010127029	36,0	PG29	31,0	36,0	29,0	48,0	10,0	40,0	43	45	10,300	25
15010127036	45,0	PG36	40,0	45,0	38,0	57,0	10,0	40,0	52	54	13,400	20
15010127048	56,0	PG48	51,0	56,0	49,0	70,0	10,0	45,0	63	66	19,130	10
15010427007	10,0	PG7	8,0	10,0	6,5	19,0	7,0	28,0	15	17	1,420	10
15010427009	14,0	PG9	11,0	14,0	10,0	23,0	7,0	30,0	19	21	2,140	10
15010427011	17,0	PG11	14,0	17,0	12,5	27,0	7,0	30,0	23	25	3,000	10
15010427013	19,0	PG13,5	16,0	19,0	14,5	29,0	7,0	30,0	25	27	3,370	10
15010427016	21,0	PG16	18,0	21,0	16,5	31,0	7,0	30,0	27	29	3,700	10
15010427021	27,0	PG21	23,0	27,0	21,5	39,0	10,0	40,0	34	36	7,350	10
15010427029	36,0	PG29	31,0	36,0	29,0	48,0	10,0	40,0	43	45	10,300	2
15010427036	45,0	PG36	40,0	45,0	38,0	57,0	10,0	40,0	52	54	13,400	2
15010427048	56,0	PG48	51,0	56,0	49,0	70,0	10,0	45,0	63	66	19,130	2

Recommendations for any areas of applications, products, or product combinations are issued to the best of FLEXA's knowledge and experience. The user is requested to check applicability of FLEXA products to specific applications and purposes prior to the use of the particular products. All documentation, illustrations, and charts published are subject to copyright and must not be copied, changed, used, or modified. Technical drawings, certificates, authorizations, and results by the FLEXA lab will be provided upon request. FLEXA will not be held liable for typographical or other errors and incorrect drawings. Technical modifications are subject to change without prior notice.