

Incremental encoders

Solid shaft $\varnothing 11$ mm with EURO flange

1000...6000 pulses per revolution

ITD 41 B10 Y 5



ITD 41 B10 Y 5 with EURO flange

Features

- Encoder with solid shaft $\varnothing 11$ mm
- Max. 6000 pulses per revolution
- Optical sensing method
- Centering alignment $\varnothing 85$ mm, mounting screw hole circle $\varnothing 100$ mm
- Industrial standard with centering flange
- TTL or HTL output signals
- Terminal box axial, screw connection radial

Optional

- Extended operating temperature range

Technical data - electrical ratings

Voltage supply	5 VDC ± 5 % 8...30 VDC
Reverse polarity protection	Yes
Consumption w/o load	≤ 100 mA
Pulses per revolution	1000...6000
Reference signal	Zero pulse, width 90°
Sensing method	Optical
Output frequency	≤ 300 kHz (TTL) ≤ 160 kHz (HTL)
Output signals	A, B, N + inverted
Output stages	TTL linedriver (short-circuit proof) HTL push-pull (short-circuit proof)
Interference immunity	DIN EN 61000-6-2
Emitted interference	DIN EN 61000-6-3

Technical data - mechanical design

Size (flange)	$\varnothing 115$ mm
Shaft type	$\varnothing 11$ mm solid shaft
Admitted shaft load	≤ 60 N axial ≤ 100 N radial
Flange	EURO flange B10
Protection DIN EN 60529	IP 65
Operating speed	≤ 8000 rpm
Starting torque	≤ 0.015 Nm (+20 °C)
Materials	Housing: aluminium Shaft: stainless steel
Operating temperature	-20...+70 °C -20...+100 °C
Relative humidity	90 % non-condensing
Resistance	DIN EN 60068-2-6 Vibration 10 g, 55-2000 Hz DIN EN 60068-2-27 Shock 30 g, 11 ms
Connection	Terminal box, 12-pin, M16x1.5 connection, radial
Weight approx.	1150 g

Incremental encoders

Solid shaft $\varnothing 11$ mm with EURO flange
1000...6000 pulses per revolution

ITD 41 B10 Y 5

Part number

ITD 41 B10 Y 5

		NI	VR16		11	IP65
--	--	----	------	--	----	------

Protection

IP65 IP 65

Flange / Solid shaft

11 EURO flange B10 / $\varnothing 11$ mm

Operating temperature

S -20...+70 °C

E -20...+100 °C

Connection

VR16 Terminal box, axial, 12-pin, M16x1.5 connection, radial

Output signals

NI A, A inv, B, B inv, 0, 0 inv

Voltage supply / signals

T 5 VDC / TTL level, linedriver

H 8...30 VDC / HTL level, push-pull

R 8...30 VDC / TTL level, linedriver

Pulse number - see table

Pulse number

1000	1440	2048	4000
1024	1500	2500	4096
1200	1800	3000	5000
1250	2000	3600	6000

Incremental encoders

Solid shaft $\varnothing 11$ mm with EURO flange

1000...6000 pulses per revolution

ITD 41 B10 Y 5

Output signals

Clockwise rotation when looking at the mounting side.

NI-Output signals

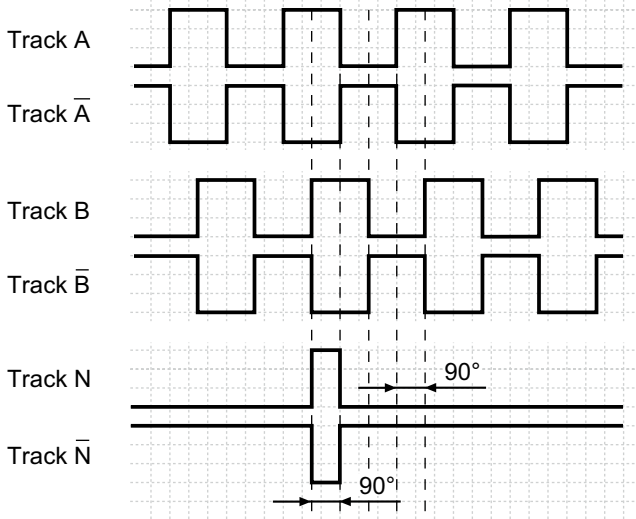

Terminal assignment

Terminal	Assignment
Pin 3	Track A
Pin 4	Track A inv.
Pin 5	Track B
Pin 6	Track B inv.
Pin 7	Track N
Pin 8	Track N inv.
Pin 2	UB
Pin 1	GND
Pin 9	UB-Sense
Pin 10	GND-Sense
Pin 11	NC
Pin 12	Shield/Housing

Trigger level

Outputs	Linedriver
Output level High	≥ 2.4 V
Output level Low	≤ 0.5 V
Load	≤ 70 mA

Outputs	Push-pull short-circuit proof
Output level High	$\geq UB - 3$ V
Output level Low	≤ 1.5 V
Load	≤ 70 mA

Dimensions

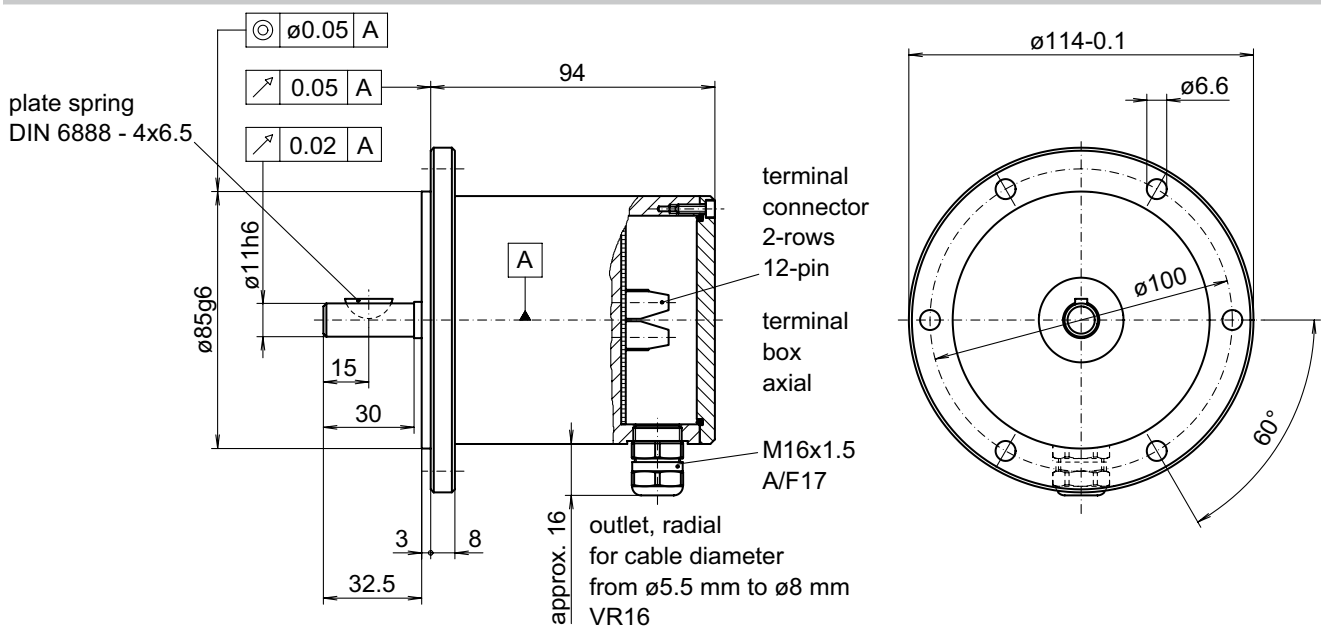

025- 7 Y 5

Incremental encoders
Solid shaft \varnothing 11 mm with EURO flange
1000...6000 pulses per revolution

ITD 41 B10 Y 5
