

# Combination

Twin tachogenerator with integrated electronic speed switch

Solid shaft with EURO flange B10 or housing foot B3

TDP 0,2 + ESL 93, TDPZ 0,2 + ESL 93



TDP 0,2 + ESL 93

## Features

- Low response time
- Open circuit voltage 20...100 mV per rpm
- EURO flange B10 or housing foot B3
- Redundant tachogenerator output (TDPZ)
- High signal quality due to patented LongLife technology
- Recognition of sense of rotation possible via control
- Electronic speed monitoring
- Circuit breaker with up to three selectable threshold speeds

## Technical data - electrical ratings

Interference immunity	EN 61000-6-2
Emitted interference	EN 61000-6-3

## Technical data - electrical ratings (tachogenerator)

Reversal tolerance	≤0.1 %
Linearity tolerance	≤0.15 %
Temperature coefficient	±0.05 %/K (open-circuit)
Isolation class	B
Calibration tolerance	±1 %
Climatic test	Humid heat, constant (IEC 60068-2-3, Ca)
Performance	TDP: 12 W (speed ≥3000 rpm) TDPZ: 2x 3 W (speed ≥3000 rpm)
Armature-circuit time-constant	<75 μs (TDP) <40 μs (TDPZ)
Open-circuit voltage	TDP: 10...150 mV per rpm TDPZ: 20...100 mV per rpm

## Technical data - electrical ratings (speed switches)

Voltage supply	12 VDC ±10 %
Consumption w/o load	≤5 mA
Switching accuracy	±4 % (≤1500 rpm) ±2 % (>1500 rpm)
Switching hysteresis	=30 % of switching speed
Switching outputs	3 outputs, speed control
Current each output	40 mA (DC)
Switching delay time	≤40 ms

## Technical data - mechanical design

Size (flange)	ø115 mm
Shaft type	ø11 mm solid shaft
Admitted shaft load	≤60 N axial ≤80 N radial
Flange	EURO flange B10 Housing foot B3
Protection DIN EN 60529	IP 55
Speed (n)	≤5000 rpm
Range of switching speed (ns)	200...5000 rpm
Torque	1.5 Ncm
Rotor moment of inertia	1.4 kgcm <sup>2</sup> (TDP) 1.5 kgcm <sup>2</sup> (TDPZ)
Materials	Housing: aluminium die-cast Shaft: stainless steel
Operating temperature	-20...+85 °C
Resistance	IEC 60068-2-6 Vibration 5 g, 10-2000 Hz IEC 60068-2-27 Shock 150 g, 1 ms
Connection	2x terminal box
Weight approx.	3.2 kg (TDP), 3.4 kg (TDPZ)
Approval	CE

# Combination

## Twin tachogenerator with integrated electronic speed switch Solid shaft with EURO flange B10 or housing foot B3

TDP 0,2 + ESL 93, TDPZ 0,2 + ESL 93

### Part number

TDP	0,2 LT-		55 + ESL93	...	...	...
						Switching speed 3 (ns3) ... 200...5000 rpm
						Switching speed 2 (ns2) ... 200...5000 rpm
						Switching speed 1 (ns1) ... 200...5000 rpm
						Mounting type B10 EURO flange B10 B3 Housing foot B3
						Open-circuit voltage 6 10 mV per rpm (not available for TDPZ) 7 20 mV per rpm 10 30 mV per rpm (not available for TDPZ) 5 40 mV per rpm 4 60 mV per rpm 3 100 mV per rpm 1 150 mV per rpm (not available for TDPZ)
						Design Tachogenerator Z Twin tachogenerator

Please indicate the exact switching rotation speeds (factory setting).

### Data according to type

Type	Open-circuit voltage $U_o$ [mV/rpm]	Minimum load required depending on speed range [rpm]			Maximum operating speed $n_{max}$ [rpm]	Armature resistance $R_A$ (20°C) [Ω]	Armature inductance $L_A$ [mH]
		0-3000 $R_L$ [kΩ]	0-6000 $R_L$ [kΩ]	0- $n_{max}$ $R_L$ [kΩ]			
TDP0,2 LT-6	10	≥0.1	≥0.3	≥0.9	10000	3	6
TDP0,2 LT-7	20	≥0.3	≥1.2	≥3.3	10000	11	23
TDP0,2 LT-10	30	≥0.7	≥2.7	≥7.5	10000	26	50
TDP0,2 LT-5	40	≥1.2	≥5	≥13.5	10000	47	90
TDP0,2 LT-4	60	≥2.7	≥11	≥30	10000	99	200
TDP0,2 LT-3	100	≥7.5	≥30	≥30	6000	271	550
TDP0,2 LT-1	150	≥16	---	≥30	4000	630	1260
Twin tachogenerator with redundant output (The data refer to each of the two tachogenerator outputs)							
TDPZ0,2 LT-7	20	≥1.2	≥4.8	≥14	10000	19	45
TDPZ0,2 LT-5	40	≥4.8	≥20	≥54	10000	70	170
TDPZ0,2 LT-4	60	≥11	≥44	≥120	10000	160	390
TDPZ0,2 LT-3	100	≥30	≥120	---	6000	445	1080
Superimposed ripple (for $\tau_{RC} = 0.7$ ms):		≤0.5% (peak-peak)			≤0.2% (rms)		

# Combination

Twin tachogenerator with integrated electronic speed switch

Solid shaft with EURO flange B10 or housing foot B3

TDP 0,2 + ESL 93, TDPZ 0,2 + ESL 93

## Replacement switching diagram

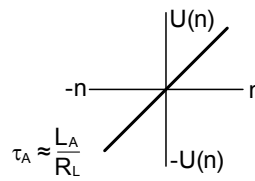
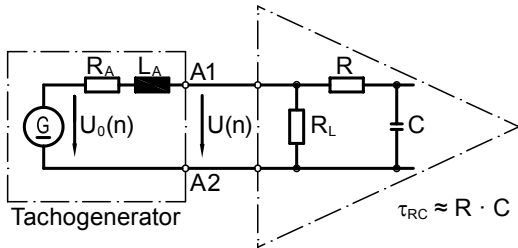

Polarity for positive rotating direction:  
 A1 (TDPZ: 1A1, 2A1): + (VDE)  
 A2 (TDPZ: 1A2, 2A2): - (VDE)

$$U(n) = U_0(n) \frac{R_L}{R_A + R_L} \approx U_0(n) \text{ for } R > R_L \gg R_A$$

## Block circuit diagram

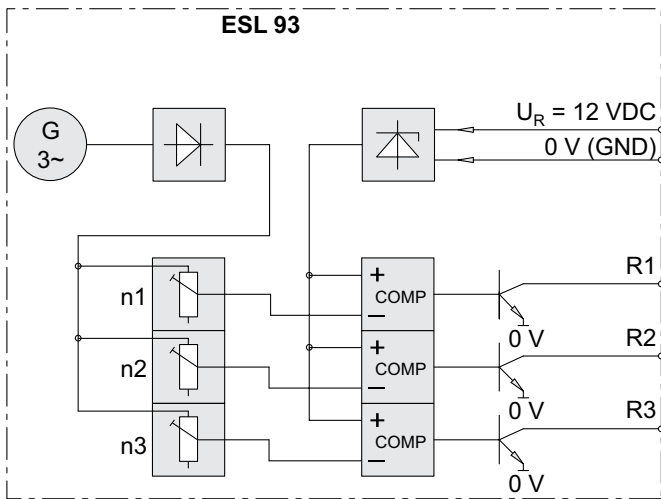

## Recommended output circuit

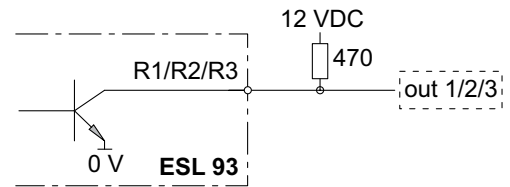

## Switching characteristics

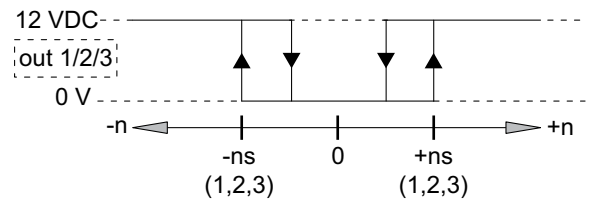

n = speed  
 ns = adjusted switching speed

# Combination

## Twin tachogenerator with integrated electronic speed switch Solid shaft with EURO flange B10 or housing foot B3

TDP 0,2 + ESL 93, TDPZ 0,2 + ESL 93

### Terminal assignment

**View A** - Connecting terminal TDP 0,2

Polarity for positive direction of rotation

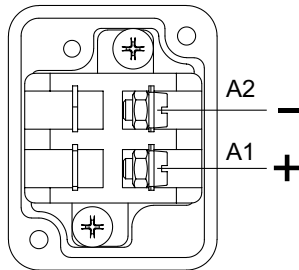

**View A** - Connecting terminal TDPZ 0,2

Polarity for positive direction of rotation

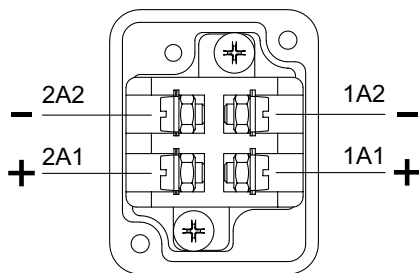

**View B** - Connecting terminal electronic speed switch ESL 93

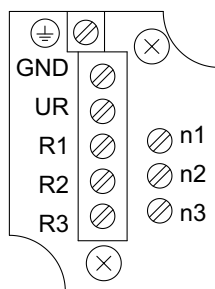

3 transistor outputs  
for connecting to a relay  
modul,  
for example ES 93 R  
(accessory)

### Accessories

Carbon brushes

### Mounting accessories

K 35 Spring washer coupling  
for solid shaft  $\varnothing 6...12$  mm

K 50 Spring washer coupling  
for solid shaft  $\varnothing 11...16$  mm

K 60 Spring washer coupling  
for solid shaft  $\varnothing 11...22$  mm

# Combination

Twin tachogenerator with integrated electronic speed switch

Solid shaft with EURO flange B10 or housing foot B3

TDP 0,2 + ESL 93, TDPZ 0,2 + ESL 93

## Dimensions

### EURO flange B10

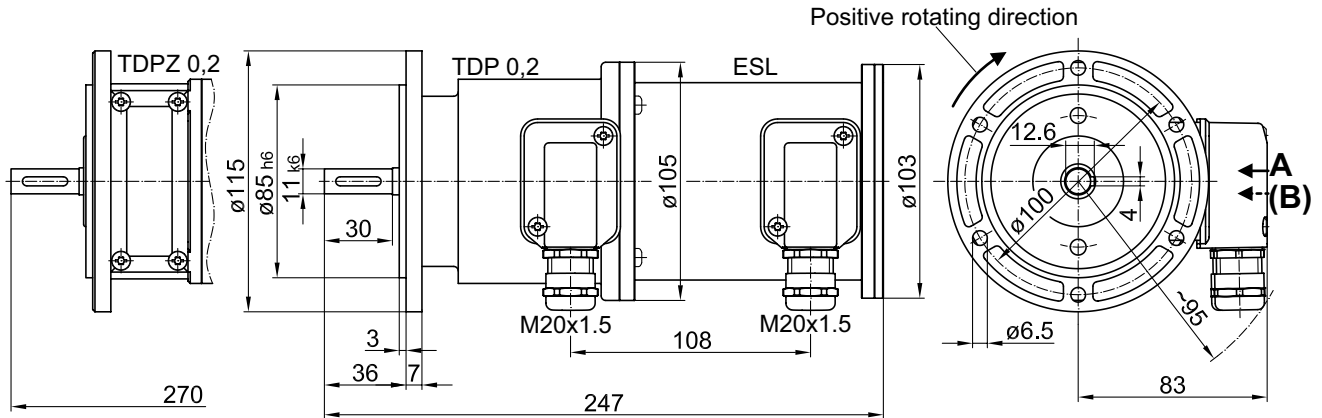

### Housing foot B3

