

Accessories

Mounting accessories

Mounting kit 098

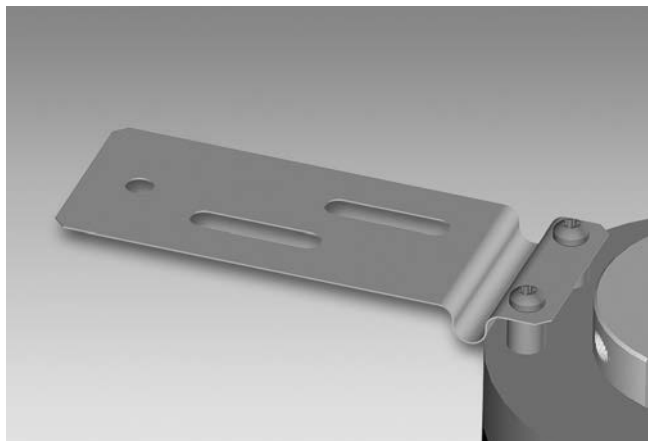

Features

- Universal mounting option by several pitch diameters.

Description

Torque support onto encoder by help of the attached screws. Push encoder onto the drive shaft and mount torque support onto the client side. Fastening clamping ring with clamping screw.

Part number

11095284 Torque arm, 1-arm, bolt circle $\varnothing 105 \dots 196$ mm, mounting M4 (mounting kit 098)

Scope of delivery

Included:
torque support, two screws M3 x 12 (DIN 7985 - TX10) with two spacers 7 mm

Dimensions

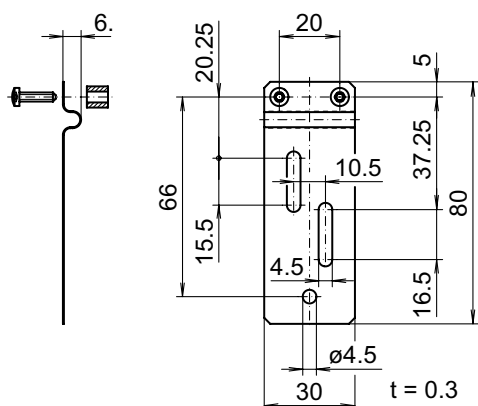

Z01536

Assembly drawing

