

Preliminary

overview

Output of calibrated 2D point cloud for further external PC processing
 Sensor parameterization via intuitive web interface
 Free SDK with example code
 Encoder & Trigger input



Technical data

general data

Measurement range MR	400 mm
Clearance distance	100 mm
Working range	100 ... 500 mm
Reference distance	300 mm
Field of view	13 mm ... 66 mm
Resolution X	30 ... 120 µm
Profiles per second	230 ... 1000 Hz
Profile points	600 pixel
Resolution Z	15 ... 55 µm
Repeat accuracy Z	20 µm
Repeat accuracy X	20 µm
Linearity deviation Z	± 0,1 %
temperature drift	± 0,04 %Sde/K

light source

Laser class	1, 2
Laser wavelength	Red (660 nm)
Laserpower	5.2 mW
Laser maximum total power	50 mW
Light point shape (at reference distance)	Line Length (x) 65 mm Line Width (z) < 400 µm

interfaces and connectors

Software / parametrisation	Integrated Webserver for parametrisation
Interfaces / output circuit	Fast-Ethernet 100-MBit/s, 2 x Switching Output, Analog Output
Protocols	UDP

electrical data

Voltage supply range +Vs	18 ... 30 VDC
Analog output signal	4-20mA, 2-10mA, 0-10V, 0-5V
Switching outputs	2 x Outputs (Push-Pull)
Power supply	typical 2.4W (100 mA max at 24 V) IEEE 802.3af Power over Ethernet (PoE)
Electrical connection	M12 12-pol, A-coded, male
Ethernet connection	M12 8-pol, X-coded, female
Encoder input specifications	4 Inputs Differential: A/B High Level: 2.5V ... +Ub / PoE 2.5 ... 24V HTL / TTL Low Level: 0 ... 1.5 V
Trigger input specification	High Level: 8V ... +Ub / PoE 8 ... 24V Low Level: < 2.5 V

mechanical data

Material	Case: Aluminium, Front Cover: Glass
Dimensions (W x H x D)	36 mm x 74 mm x 60 mm
Width	36 mm
Height	74 mm
Depth	60 mm
Weight	270 g

environmental conditions

Ambient temperature	0... + 50 °C
Storage temperature	- 10 ... + 60 °C
Ambient humidity	20 ... 85 %
Protection class (IEC 60529)	IP67

OXP200-R40C.006

Laser Line Profile Sensor

Article number: 11218606

Preliminary

Technical data

environmental conditions

Vibration (sinusoidal)	1 mm p-p at f = 10 - 55 Hz, duration 5 min per axis 30 min endurance at f = 55 Hz per axis IEC 60068-2-6:2008
Shock (semi-sinusoidal)	30 g / 11 ms, 6 jolts per axis and direction IEC 60068-2-27:2009

environmental conditions

Ambient light immunity	< 25 kLux
------------------------	-----------

conformity

Conformity	CE RoHS
------------	------------

technical drawings

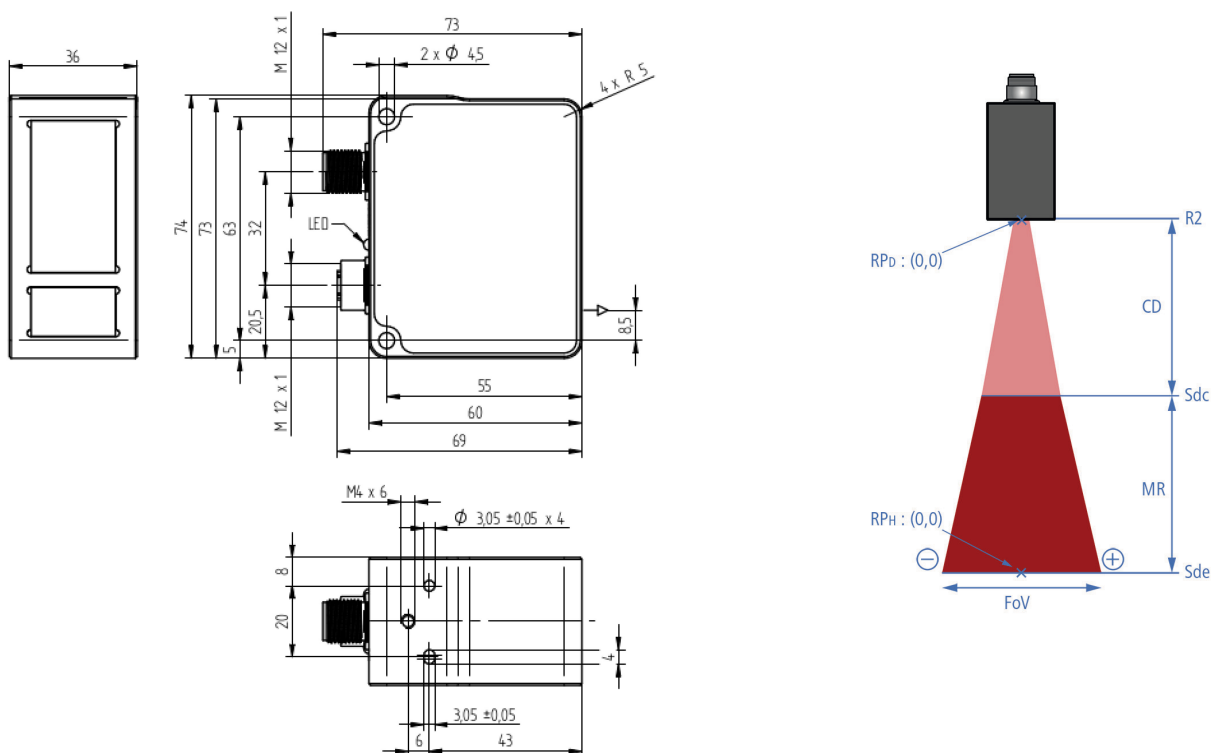

Preliminary

pin assignment

Electrical connection

M12 12-pol, A-coded, male

1	Power(18..30VDC)/2L+
2	GND/2M
3	Encoder A
4	Analog Out
5	Encoder A neg.
6	OUT1/IO-LinkC/Q
7	Encoder B
8	OUT2 (Alarm)
9	IN1 (sync in)
10	Encoder B neg.
11	IO-Link L+
12	IO-Link L-

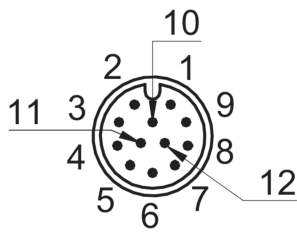

Ethernet connection

M12 8-pol, X-coded, female

1	RX +
2	RX -
3	TX +
4	TX -
5	- VDC
6	- VDC
7	+ VDC
8	+ VDC

