

# Absolute encoders - bus interfaces

Solid shaft with synchro flange

Magnetic single- or multiturn encoders 14 bit ST / 18 bit MT

## EAM360R-S - CANopen®/SAE J1939 - MAGRES



EAM360R with synchro flange

### Features

- Encoder single- or multiturn / CANopen®/SAE J1939
- ISO 13849 compliant firmware
- E1 compliant design
- High protection IP 67
- High resistance to shock and vibrations
- Protection against corrosion C5-M
- Wire cross section 0.5 mm<sup>2</sup>
- Electronic gear function

### Technical data - electrical ratings

Voltage supply	10...30 VDC
Consumption typ.	20 mA (24 VDC, w/o load)
Initializing time	≤170 ms after power on
Interfaces	CANopen®, SAE J1939
Function	Multiturn, Singleturn
Profile conformity	CANopen® CiA communication profile DS 301, LSS profile DSP 305, device profile DS 406
Steps per revolution	≤16384 / 14 bit
Number of revolutions	≤262144 / 18 bit
Absolute accuracy	±0.15 ° (+20 ±15 °C) ±0.25 ° (-40...+85 °C)
Sensing method	Magnetic
Code sequence	CW: ascending values with clockwise sense of rotation; looking at flange
Output stages	CAN-Bus, LV (3.3 V) compatible ISO 11898
Interference immunity	DIN EN 61000-6-2 ISO 11452-2:2004* / -5:2002* ISO 7637-2:2004* ISO 10605:2008 + Amd 1:2014 (CD ±8 kV / AD ±15 kV) * Severity level according to ECE R10 (Rev. 4)
Emitted interference	DIN EN 61000-6-4 CISPR 25:2008 (30..1000 MHz) ISO 7637-2:2004* * Severity level according to ECE R10 (Rev. 4)

### Technical data - mechanical design

Size (flange)	ø36 mm
Shaft type	ø10 x 16 mm, solid shaft with flat
Flange	Synchro flange
Protection DIN EN 60529	IP 67 (with shaft seal)
Operating speed	≤6000 rpm
Starting torque	≤2.5 Ncm (+20 °C, IP 67)
Moment of inertia	15.38 gcm <sup>2</sup>
Admitted shaft load	≤40 N axial ≤80 N radial
Materials	Housing: steel, powder-coated Flange: aluminium Shaft: stainless steel
Corrosion protection	IEC 60068-2-52 Salt mist for ambient conditions C5-M (CX) according to ISO 12944-2
Operating temperature	-40...+85 °C (see general information)
Relative humidity	95 %
Resistance	DIN EN 60068-2-6 Vibration 30 g, 10-2000 Hz DIN EN 60068-2-27 Shock 500 g, 1 ms
Weight approx.	170 g
Connection	Flange connector M12, 5-pin Cable 2 m
Instruction	Use in safety functions exclusively based on Application Note and MTTFd reliability prediction (request separately).



# Absolute encoders - bus interfaces

## Solid shaft with synchro flange

### Magnetic single- or multiturn encoders 14 bit ST / 18 bit MT

#### EAM360R-S - CANopen®/SAE J1939 - MAGRES

##### CANopen® features

Operating modes	Timer-driven (Event-Time) Synchronously triggered (Sync)
Node Monitoring	Heartbeat Node guarding
Programmable parameters	Operating modes Total resolution Scaling Electronic gear function
Diagnosis	Multiturn sensing Position error Temperature exceeding Speed exceeding
Default	50 kbit/s, Node ID 1 (DS406) 250 kbit/s, Node ID 4 (DS417)

##### SAE J1939 features

Programmable parameters	Total resolution Scaling
Diagnosis	Multiturn sensing Position error Temperature exceeding Speed exceeding
Default	250 kbit/s ECU address 172

##### General information

Self-heating interrelated to speed, protection, attachment method and ambient conditions as well electronics and supply voltage must be considered for precise thermal dimensioning. Self-heating is supposed to approximate 8 K (IP 67 protection) per 1000 rpm. Operating the encoder close to the maximum limits requires measuring the real prevailing temperature at the encoder flange.

##### Terminal assignment

###### Cable

for connection reference -L

Core colour	Signals
white	0 V
brown	+Vs
green	CAN_H
yellow	CAN_L
grey	CAN_GND

Cable data: 5 x 0.5 mm<sup>2</sup>

###### Flange connector M12, 5-pin

for connection reference -N

Pin	Signals
1	CAN_GND
2	+Vs
3	0 V
4	CAN_H
5	CAN_L

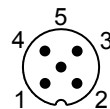

# Absolute encoders - bus interfaces

Solid shaft with synchro flange

Magnetic single- or multiturn encoders 14 bit ST / 18 bit MT

EAM360R-S - CANopen®/SAE J1939 - MAGRES

## Dimensions

EAM360R, cable

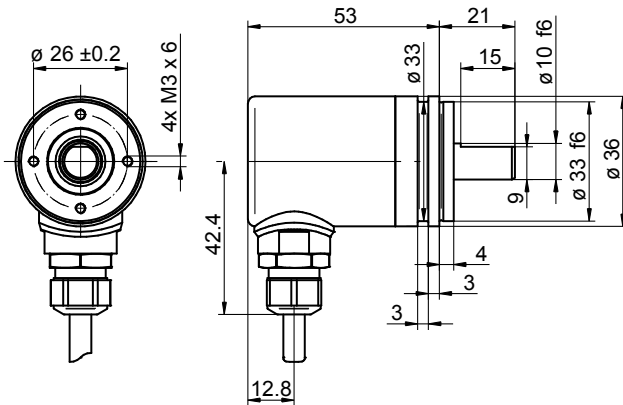

EAM360R, M12

