

# Incremental encoders

## Solid shaft $\varnothing 11$ mm with EURO flange

### 200...2048 pulses per revolution

#### ITD 40 B10 Y 1



ITD 40 B10 Y 1 with EURO flange

#### Features

- Encoder with solid shaft  $\varnothing 11$  mm
- Max. 2048 pulses per revolution
- Optical sensing method
- Centering alignment  $\varnothing 85$  mm, mounting screw hole circle  $\varnothing 100$  mm
- Industrial standard with centering flange
- TTL or HTL output signals
- Flange connector radial or axial

#### Optional

- Extended operating temperature range

#### Technical data - electrical ratings

Voltage supply	5 VDC $\pm 5$ % 8...30 VDC
Reverse polarity protection	Yes
Consumption w/o load	$\leq 100$ mA
Pulses per revolution	200...2048
Reference signal	Zero pulse, width $90^\circ$
Sensing method	Optical
Output frequency	$\leq 120$ kHz
Output signals	A, B, N + inverted
Output stages	TTL linedriver (short-circuit proof) HTL push-pull (short-circuit proof)
Interference immunity	DIN EN 61000-6-2
Emitted interference	DIN EN 61000-6-3

#### Technical data - mechanical design

Size (flange)	$\varnothing 115$ mm
Shaft type	$\varnothing 11$ mm solid shaft
Admitted shaft load	$\leq 40$ N axial $\leq 60$ N radial
Flange	EURO flange B10
Protection DIN EN 60529	IP 65
Operating speed	$\leq 12000$ rpm
Starting torque	$\leq 0.012$ Nm (+20 °C)
Materials	Housing: aluminium Shaft: stainless steel
Operating temperature	-20...+70 °C -20...+100 °C
Relative humidity	90 % non-condensing
Resistance	DIN EN 60068-2-6 Vibration 10 g, 55-2000 Hz DIN EN 60068-2-27 Shock 100 g, 11 ms
Connection	Connector M23 type 2, 12-pin
Weight approx.	850 g



# Incremental encoders

Solid shaft  $\varnothing 11$  mm with EURO flange  
200...2048 pulses per revolution

## ITD 40 B10 Y 1

### Output signals

Clockwise rotation when looking at the mounting side.

#### BI-Output signals

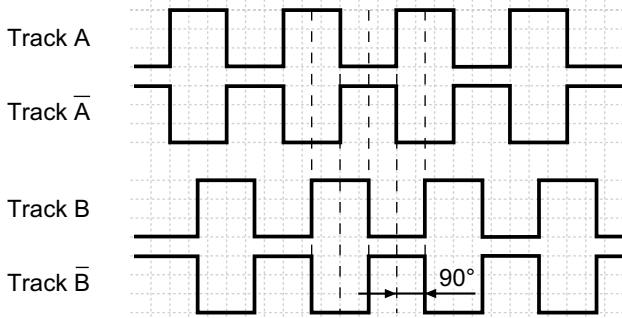

#### NI-Output signals

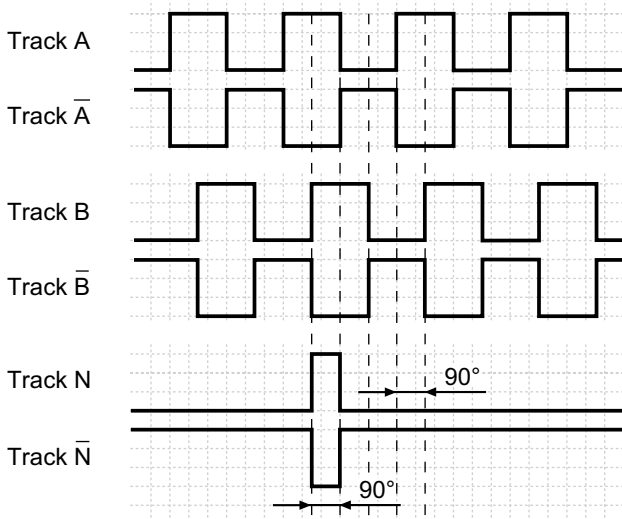

### Terminal assignment

Connector	Assignment
Pin 5	Track A
Pin 6	Track A inv.
Pin 8	Track B
Pin 1	Track B inv.
Pin 3	Track N
Pin 4	Track N inv.
Pin 12	UB
Pin 10	GND
Pin 2	UB-Sense
Pin 11	GND-Sense
Pin 9	–
Pin 7	–

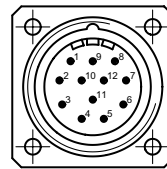

### Trigger level

Outputs	Linedriver
Output level High	$\geq 2.4$ V
Output level Low	$\leq 0.5$ V
Load	$\leq 70$ mA

Outputs	Push-pull short-circuit proof
Output level High	$\geq UB - 3$ V
Output level Low	$\leq 1.5$ V
Load	$\leq 70$ mA

# Incremental encoders

Solid shaft  $\varnothing 11$  mm with EURO flange  
200...2048 pulses per revolution

ITD 40 B10 Y 1

## Dimensions

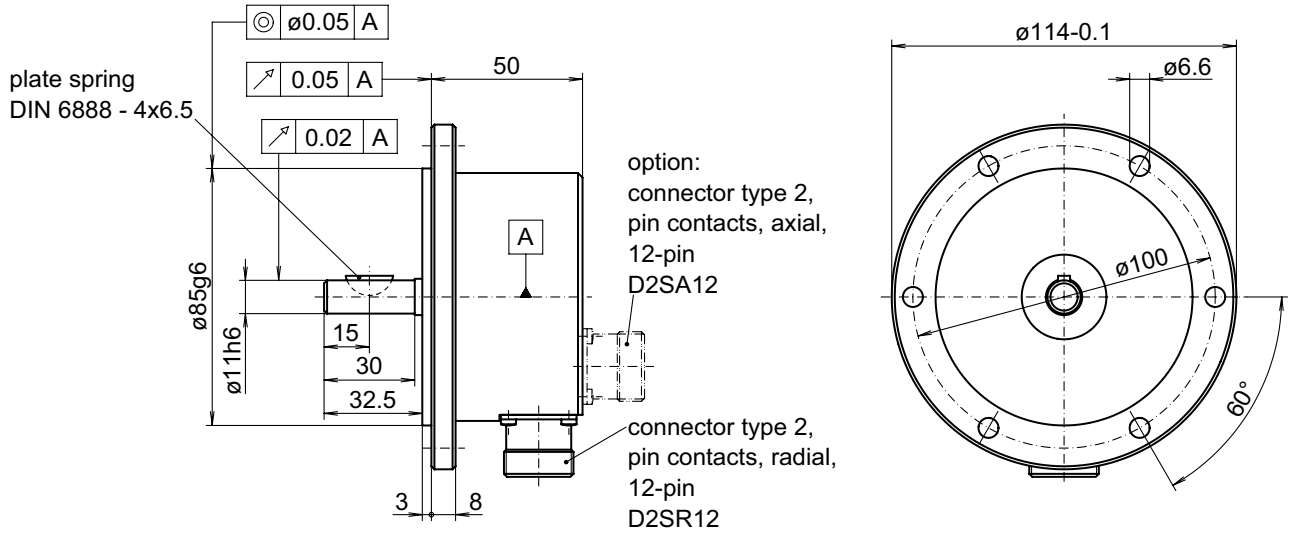

025- 7 Y 1