

Combination

Twin encoder with two electrically separated systems

Blind hollow shaft or cone shaft

300...5000 pulses per revolution

HOG 10 G



HOG 10 G

Technical data - electrical ratings

Voltage supply	9...30 VDC 5 VDC \pm 5 %
Consumption w/o load	\leq 100 mA
Pulses per revolution	300...5000
Phase shift	90° \pm 20°
Duty cycle	40...60 %
Reference signal	Zero pulse, width 90°
Output frequency	\leq 120 kHz \leq 300 kHz (on request)
Output signals	K1, K2, K0 + inverted Error output (option EMS)
Output stages	HTL-P (power linedriver) TTL/RS422
Sensing method	Optical
Shaft insulation	Suitable up to 2.8 kV
Transmission length	\leq 350 m at 100 kHz (HTL-P) \leq 550 m at 100 kHz (TTL)
Interference immunity	EN 61000-6-2
Emitted interference	EN 61000-6-3
Approvals	CE, UL approval / E256710

Features

- Twin encoder featuring two separate systems
- TTL output driver for cable length up to 550 m
- Very high resistance to shock and vibrations
- Hybrid bearing for extended service life
- Large terminal boxes, turn by 180°

Optional

- Function control with EMS
(Enhanced Monitoring System)
- Redundant sensing with two terminal boxes for each system

Technical data - mechanical design

Size (flange)	\varnothing 105 mm
Shaft type	\varnothing 16...20 mm (blind hollow shaft) \varnothing 17 mm (cone shaft 1:10)
Admitted shaft load	\leq 450 N axial \leq 600 N radial
Protection DIN EN 60529	IP 66
Operating speed	\leq 6000 rpm (mechanical)
Operating torque typ.	6 Ncm
Rotor moment of inertia	340 gcm ²
Materials	Housing: aluminium die-cast Shaft: stainless steel
Operating temperature	-40...+100 °C -25...+100 °C (>3072 pulses per revolution)
Resistance	IEC 60068-2-6 Vibration 20 g, 10-2000 Hz IEC 60068-2-27 Shock 300 g, 6 ms
Corrosion protection	IEC 60068-2-52 Salt mist for ambient conditions C4 according to ISO 12944-2
Explosion protection	II 3 G Ex nA IIC T4 Gc (gas) II 3 D Ex tc IIIC T135°C Dc (dust)
Connection	2x terminal box 4x terminal box (with option M)
Weight approx.	2.9 kg, 3.3 kg (with option M)

Combination

Twin encoder with two electrically separated systems

Blind hollow shaft or cone shaft

300...5000 pulses per revolution

HOG 10 G

Output signals

At positive rotating direction

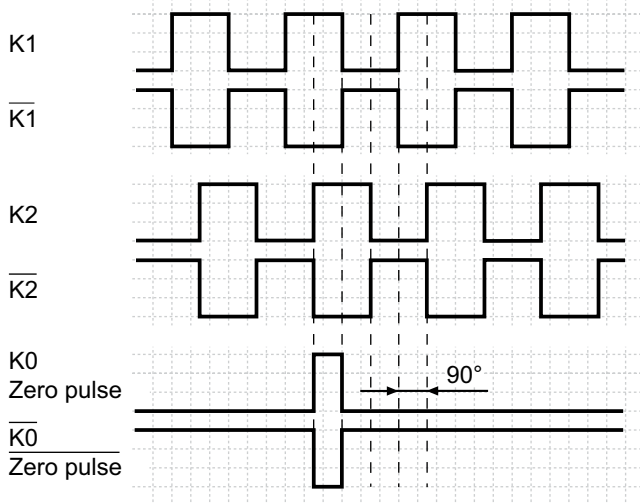

Terminal significance

+UB	Voltage supply (for the device)
⊥; ⚡; GND; 0 V	Ground (for the signals)
⊕; ⚡	Earth ground (housing)
K1; A; A+	Output signal channel 1
K1-bar; A-bar; A-	Output signal channel 1 inverted
K2; B; B+	Output signal channel 2 (offset by 90° to channel 1)
K2-bar; B-bar; B-	Output signal channel 2 (offset by 90° to channel 1) inverted
K0; C; R; R+	Zero pulse (reference signal)
K0-bar; C-bar; R-bar; R-	Zero pulse (reference signal) inverted
Err-bar; Err-	Error output (option EMS)
dnu	Do not use

Terminal assignment

View A

Connecting terminal terminal box

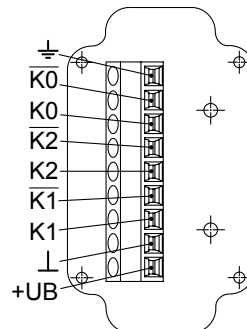

Option EMS: View A

Connecting terminal terminal box

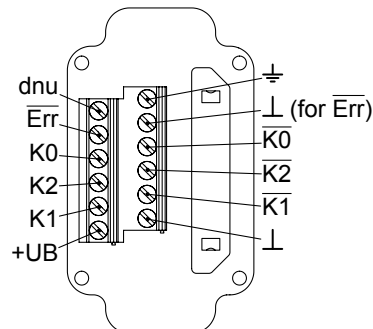

Option EMS: LED status / Error output

Flash light red*	Error of signal sequence, zero pulse or pulses (Error output = HIGH-LOW alternation)
Red	Overload output driver (Error output = LOW)
Flash light green	Device o.k., rotating (Error output = HIGH)
Green	Device o.k., stopped (Error output = HIGH)
No light	No voltage supply connection or wrong connection (Error output = LOW)

* Only at rotating device

Combination

Twin encoder with two electrically separated systems

Blind hollow shaft or cone shaft

300...5000 pulses per revolution

HOG 10 G

Accessories

Connectors and cables

HEK 8	Sensor cable for encoders
-------	---------------------------

Mounting accessories

11077197	Mounting kit for torque arm size M6 and earthing strap
11077087	Mounting and dismantling set
11043628	Torque arm M6, length 67-70 mm
11004078	Torque arm M6, length 120-130 mm (shortenable ≥ 71 mm)
11002915	Torque arm M6, length 425-460 mm (shortenable ≥ 131 mm)
11054917	Torque arm M6 insulated, length 67-70 mm
11072795	Torque arm M6 insulated, length 120-130 mm (shortenable ≥ 71 mm)
11082677	Torque arm M6 insulated, length 425-460 mm (shortenable ≥ 131 mm)

Diagnostic accessories

11075858	Analyzer for encoders HENQ 1100
11075880	Analyzer for encoders HENQ 1100 with a power pack

Combination

Twin encoder with two electrically separated systems

Blind hollow shaft or cone shaft

300...5000 pulses per revolution

HOG 10 G

Dimensions

Blind hollow shaft

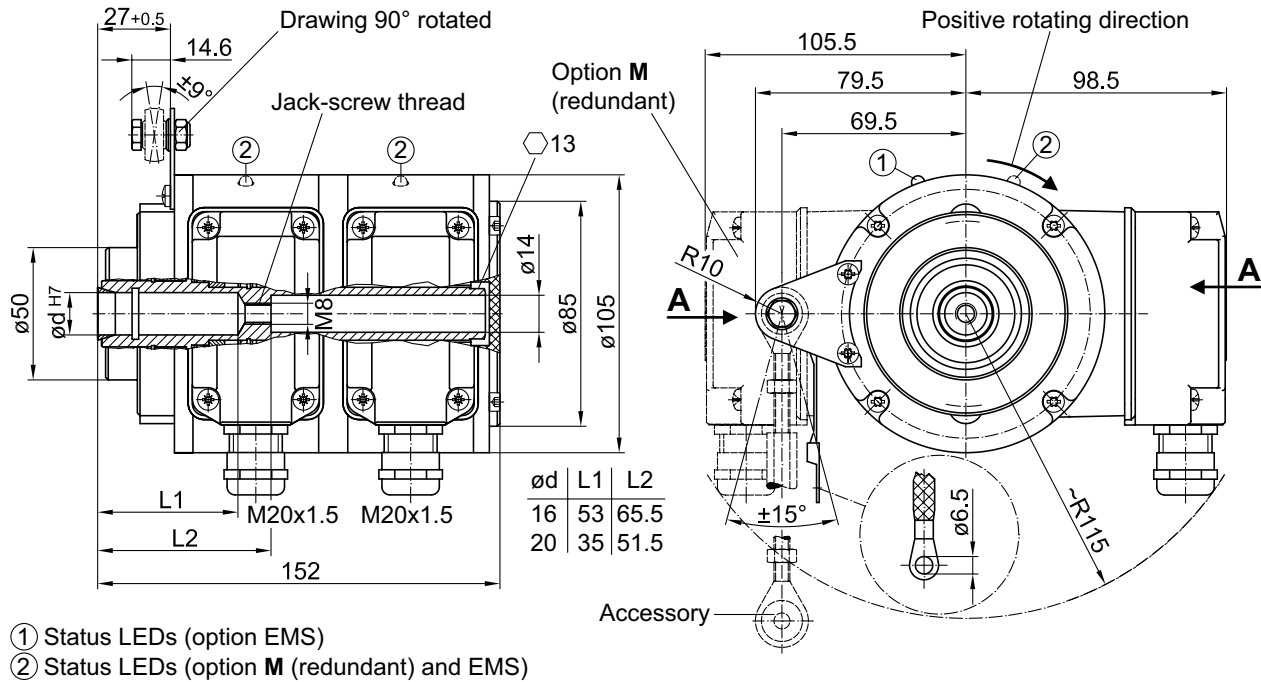

Cone shaft

