

Encoders without bearings - incremental

Incremental encoder with optical sensing

Through hollow shaft $\varnothing 85...95$ mm

2500 pulses per revolution

HG 21

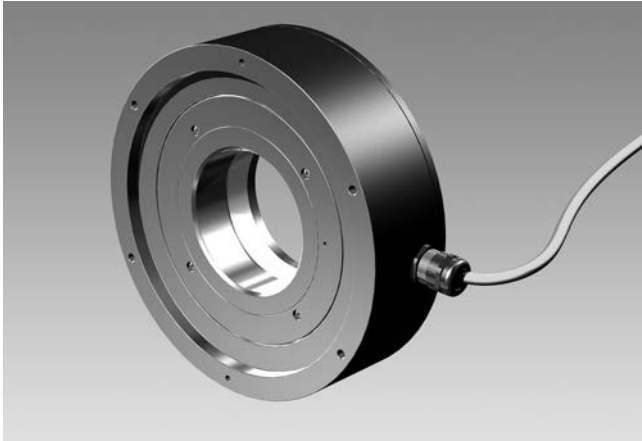

HG 21

Technical data - electrical ratings

Voltage supply	9...26 VDC 5 VDC ± 5 %
Consumption w/o load	≤ 100 mA
Pulses per revolution	2500
Output signals	K1, K2, K0 + inverted
Reference signal	Zero pulse, width 90°
Output frequency	≤ 120 kHz ≤ 160 kHz (Option)
Phase shift	$90^\circ \pm 20^\circ$
Duty cycle	40...60 %
Sensing method	Optical
Output stages	HTL TTL/RS422
Interference immunity	EN 61000-6-2
Emitted interference	EN 61000-6-3
Approvals	CE, UL approval / E256710

Features

- Large axial and radial displacement of the shaft permitted
- Fit for high operating speed
- Robust and wearless
- 2500 pulses per revolution
- Logic level TTL with regulator UB 9...26 VDC

Optional

- Redundant sensing (option M)

Technical data - mechanical design

Size (flange)	$\varnothing 240$ mm
Shaft type	$\varnothing 85...95$ mm (through hollow shaft)
Axial tolerance	-0.5...1.5 mm (with zero pulse) -0.5...2.5 mm (without zero pulse)
Radial tolerance	± 0.05 mm (with zero pulse) ± 0.2 mm (without zero pulse)
Protection DIN EN 60529	IP 44
Operating speed	≤ 12000 rpm
Materials	Housing: aluminium Shaft: stainless steel
Rotor moment of inertia	43 kgcm ²
Operating temperature	-30...+70 °C
Resistance	IEC 60068-2-6 Vibration 10 g, 10-2000 Hz IEC 60068-2-27 Shock 100 g, 6 ms
Weight approx.	5.8 kg
Connection	Cable with mating connector, 12-pin (2x with option M)

Encoders without bearings - incremental

Incremental encoder with optical sensing

Through hollow shaft $\varnothing 85...95$ mm

2500 pulses per revolution

HG 21

Part number

HG 21

			2500	
--	--	--	------	--

Voltage supply / signals

- 9...26 VDC / output stage HTL
- CI 9...26 VDC / output stage HTL (C) with inverted signals
- TTL 5 VDC / output stage TTL with inverted signals
- R 9...26 VDC / output stage TTL with inverted signals (for output signals DN)

Output signals

- D K1, K2
- DN K1, K2, K0

Redundant sensing

- Without redundant sensing
- M With redundant sensing

Encoders without bearings - incremental

Incremental encoder with optical sensing

Through hollow shaft $\varnothing 85...95$ mm

2500 pulses per revolution

HG 21

Output signals

At positive rotating direction

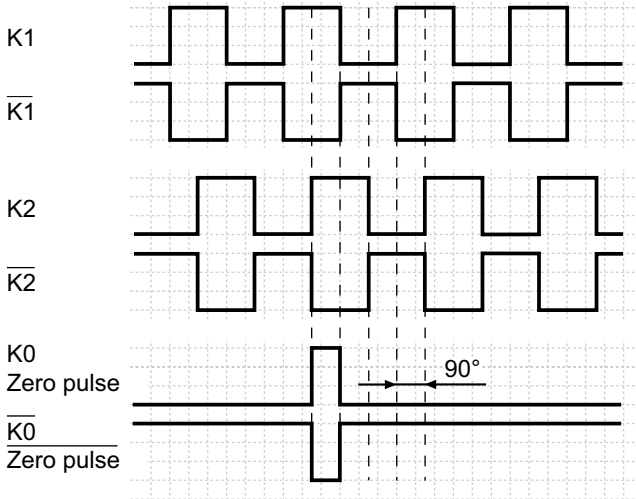

Terminal assignment

View A - Mating connector, 12 pin, male contacts, CW

Pin	Assignment
1	$\overline{K2}$ (K2 inv.)
2	Do not use
3	K0 (Zero pulse)
4	$\overline{K0}$ (Zero pulse inv.)
5	K1
6	$\overline{K1}$ (K1 inv.)
7	Do not use
8	K2
9	Do not use
10	0 V
11	Do not use
12	+UB

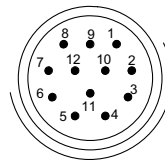

Dimensions

