

Incremental encoders

Solid shaft with clamping flange

1...65536 pulses per revolution programmable (interpolated system)

ExEIL580P-SC



ExEIL580P-SC with clamping flange

Features

- Size $\varnothing 58$ mm
- Precise optical sensing (interpolated)
- Output signal level programmable (TTL or HTL)
- Clamping flange
- Connection axial, radial or tangential
- Pulses per revolution 1...65536, programmable
- High resistance to shock and vibrations
- Option 0122, Explosion protection zone 22

Technical data - electrical ratings

Voltage supply	4.75...30 VDC
Reverse polarity protection	Yes
Short-circuit proof	Yes
Consumption w/o load	≤ 70 mA
Initializing time	≤ 30 ms after power on
Pulses per revolution	1...65536
Duty cycle	45...55 % typical at 1024, 2048 ppr (further see table Duty cycle)
Reference signal	Zero pulse 90° or 180°
Sensing method	Optical
Output frequency	≤ 300 kHz (TTL) ≤ 160 kHz (HTL)
Output signals	A+, B+, R+, A-, B-, R-
Output stages	TTL/RS422 HTL/push-pull
Programmable parameters	Output level TTL/HTL Pulse number 1...65536 Zero pulse width $90^\circ/180^\circ$ Zero pulse position Signal sequence
Interference immunity	DIN EN 61000-6-2
Emitted interference	DIN EN 61000-6-3
Approval	UL 508 / CSA 22.2

Technical data - mechanical design

Size (flange)	$\varnothing 58$ mm
Shaft type	$\varnothing 10 \times 20$ mm, solid shaft with flat
Admitted shaft load	≤ 40 N axial ≤ 80 N radial
Flange	Clamping flange
Protection DIN EN 60529	IP 65
Operating speed	≤ 12000 rpm (+20 °C) ≤ 11000 rpm (+40 °C) ≤ 8000 rpm (+60 °C)
Starting torque	≤ 0.015 Nm (+20 °C)
Materials	Housing: aluminium die-cast Flange: aluminium Solid shaft: stainless steel
Ambient temperature	-20...+60 °C
Relative humidity	90 % non-condensing
Resistance	DIN EN 60068-2-6 Vibration 30 g, 10-2000 Hz DIN EN 60068-2-27 Shock 300 g, 6 ms
Explosion protection	II 3 D Ex tc IIIC T135°C Dc X (dust): see special conditions "X"
Connection	Flange connector M12, 8-pin Flange connector M23, 12-pin Cable
Weight approx.	300 g

Incremental encoders

Solid shaft with clamping flange

1...65536 pulses per revolution programmable (interpolated system)

ExEIL580P-SC

Part number

ExEIL580P-S

C	10	.	5		F	.	01024	.F/	0122
---	----	---	---	--	---	---	-------	-----	------

Option

0122 ATEX Zone 22

Pulses programmable

01024 1...65536 programmable (factory setting: 1024)

Voltage supply / output stages

F 4.75...30 VDC, TTL/RS422, 6 channel (Vout = 5 VDC) - Factory setting
HTL/push-pull 6 channel (Vout = Vin) - programmable by customer

Connection

- R Cable radial, 1 m
- L Cable radial, 2 m
- F Flange connector M23, 12-pin, radial, male contacts, CCW
- B Flange connector M12, 8-pin, radial, male, CCW
- T Cable axial, 1 m
- U Cable axial, 2 m
- D Flange connector M23, 12-pin, axial, male, CCW
- A Flange connector M12, 8-pin, axial, male, CCW
- P Cable tangential, 1 m
- Q Cable tangential, 2 m

Protection

5 IP 65

Specification solid shaft

10 ø10 x 20 mm, with flat

Flange

C Clamping flange, centering collar ø36 mm, M3/M4

(Factory setting: 1024 ppr, Vout = 5 VDC TTL, signal sequence A leading B (CW), zero pulse 90° A&B high)

Incremental encoders

Solid shaft with clamping flange

1...65536 pulses per revolution programmable (interpolated system)

ExEIL580P-SC

Accessories

Connectors and cables

10127844	Connection cable 2 m shielded with female connector M12, 8-pin, straight (ESG 34FH0200G)
10129332	Connection cable 5 m shielded with female connector M12, 8-pin, straight (ESG 34FH0500G)
10129333	Connection cable 10 m shielded with female connector M12, 8-pin, straight (ESG 34FH1000G)
11053961	Connection cable 2 m shielded with female connector M12, 8-pin, angled (ESW 33FH0200G)
11053962	Connection cable 5 m shielded with female connector M12, 8-pin, angled (ESW 33FH0500G)
10170054	Connection cable 10 m shielded with female connector M12, 8-pin, angled (ESW 33FH1000G)
11212849	Connection cable 1 m shielded with female connector M23, 12-pin - EIL580P
11212870	Connection cable 2 m shielded with female connector M23, 12-pin - EIL580P
11212871	Connection cable 5 m shielded with female connector M23, 12-pin - EIL580P
11212872	Connection cable 10 m shielded with female connector M23, 12-pin - EIL580P
11119280	Connection cable connector M12 / connector D-SUB, 0.2 m
11119720	Connection cable connector M12 / connector D-SUB, 1 m
11119257	Connection cable connector M23 / connector D-SUB, 0.2 m (S2BG12/K4SG9)
11119723	Connection cable connector M23 / connector D-SUB, 1 m (S2BG12/K4SG9)

Mounting accessories

11065915	Coupling CPS25 L=19 d1=04/d2=10
11065918	Coupling CPS25 L=19 d1=07/d2=10
11065920	Coupling CPS25 L=19 d1=08/d2=10
11065921	Coupling CPS25 L=19 d1=09/d2=10
11065922	Coupling CPS25 L=19 d1=10/d2=06
11065923	Coupling CPS25 L=19 d1=10/d2=10
11065924	Coupling CPS25 L=19 d1=10/d2=11
11065925	Coupling CPS25 L=19 d1=10/d2=12
10141132	Spring washer coupling D1=6 / D2=10 (Z 121.C01)
10141133	Spring washer coupling D1=10 / D2=10 (Z 121.C03)
11034138	Spring washer coupling D1=10 / D2=16 (Z 121.C04)

Mounting accessories

11034140	Spring washer coupling D1=10 / D2=14 (Z 121.C06)
11034141	Spring washer coupling D1=10 / D2=12 (Z 121.C07)
11050507	Bellows coupling aluminium/stainless steel D1=06 / D2=10
11101781	Double loops coupling D1=10 / D2=10
10125051	Mounting adaptor for encoders with clamping flange (M3) (Z 119.017)
11065545	Set of eccentric fixings type A
11101893	Tether arm

Programming accessories

11120657	Handheld Programming Tool Z-PA-EI-H
11120547	PC Programming Tool Z-PA-EI-P

Matching measuring wheels available as accessories, see under "measuring wheels" (MR).

Incremental encoders

Solid shaft with clamping flange

1...65536 pulses per revolution programmable (interpolated system)

ExEIL580P-SC

Output signals

Zero pulse electrical 90° A&B high
(Factory setting at clockwise rotation (CW)
in view of the encoder flange)

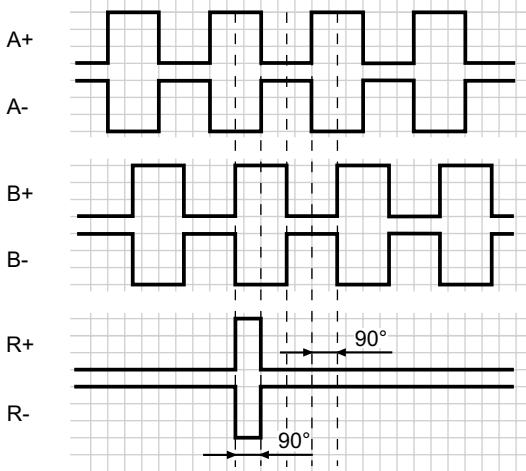

Zero pulse electrical 180° B low
(at clockwise rotation (CW)
in view of the encoder flange)

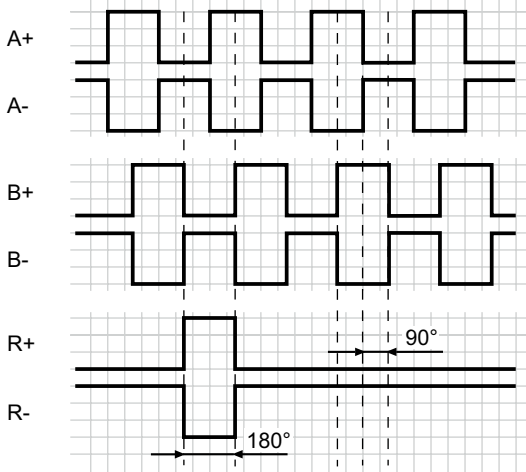

Trigger level

Outputs	TTL/RS422
Output level High	≥ 2.5 V
Output level Low	≤ 0.5 V
Load	≤ 20 mA

Outputs	HTL/Push-pull
Output level High	$\geq UB - 3$ V
Output level Low	≤ 1.5 V
Load	≤ 20 mA

Terminal assignment

Flange connector M23, 12-pin / cable

Pin	Core color	Assignment
1	pink	B-
2	–	–
3	blue	R+
4	red	R-
5	green	A+
6	yellow	A-
7	–	R-Set ¹⁾
8	grey	B+
9	–	–
10	white	GND
11	–	–
12	brown	UB

Screen: Connected to housing

Cable data: PUR, [4x2x0,14 mm²], bending radius
>45,8 mm, outer diameter 6.1 mm

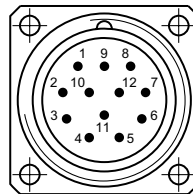

¹⁾ The R-Set input is used to set the reference pulse (zero pulse) on the current shaft position.
R-Set = UB ≥ 200 ms

Flange connector M12, 8-pin

Pin	Assignment
1	GND
2	UB
3	A+
4	A-
5	B+
6	B-
7	R+
8	R-

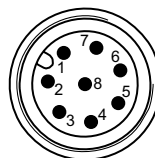

Incremental encoders

Solid shaft with clamping flange

1...65536 pulses per revolution programmable (interpolated system)

ExEIL580P-SC

Duty cycle

The duty cycle (D) is defined as the time ratio between the HIGH pulse duration (H) and the pulse period (T).

System-induced and depending on the pulse number, the measured values may vary which has an impact on speed and position acquisition.

Binary pulse numbers are recommended for speed feedback.

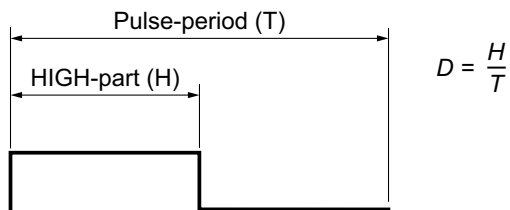

Programmed pulse number	Scan ratio (D) (maximum)	Jitter (+/-) (maximum)
1...1023	45...55 %	5%
1024, 2048	45...55 %	5%
1025...5000	40...60 %	10%
8192, 16384	35...85 %	15%
5001...10000	22...78 %	28%
32768	25...75 %	25%
65536	15...85 %	35%
all other	Jitter[%]=(programmed pulse number -10000)*0,0007%+28%	

Incremental encoders

Solid shaft with clamping flange

1...65536 pulses per revolution programmable (interpolated system)

ExEIL580P-SC

Dimensions

Flange connector M12, radial

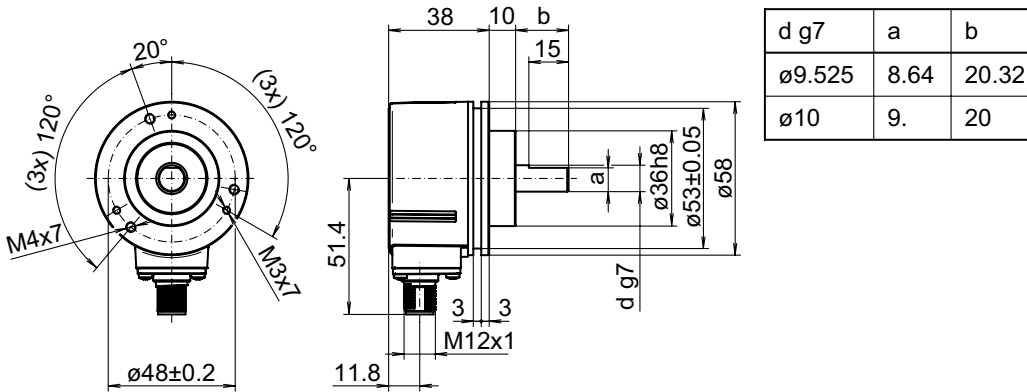

Flange connector M23, radial

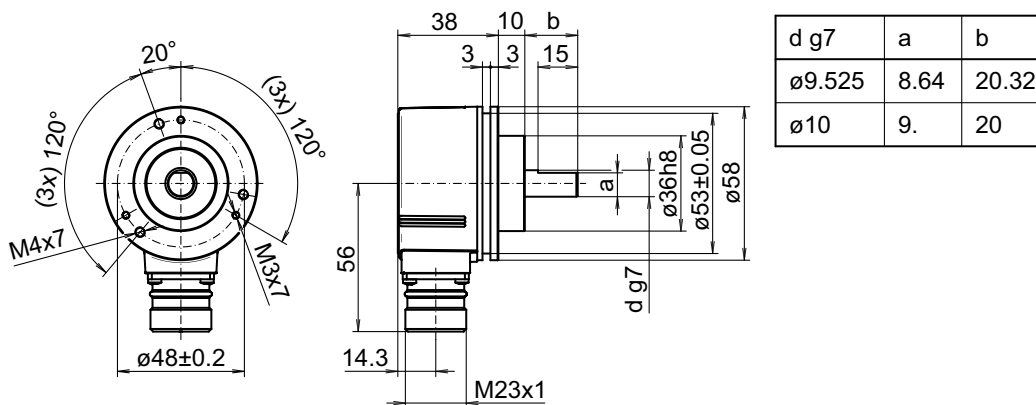

Cable, radial

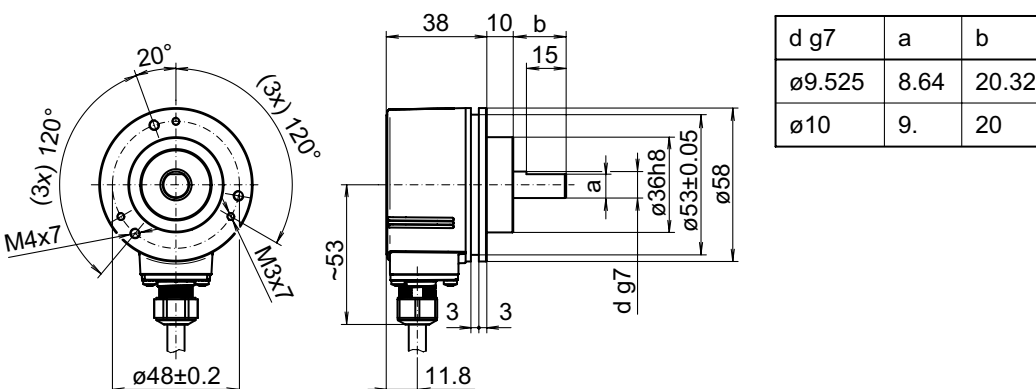

Incremental encoders

Solid shaft with clamping flange

1...65536 pulses per revolution programmable (interpolated system)

ExEIL580P-SC

Dimensions

Flange connector M12, axial

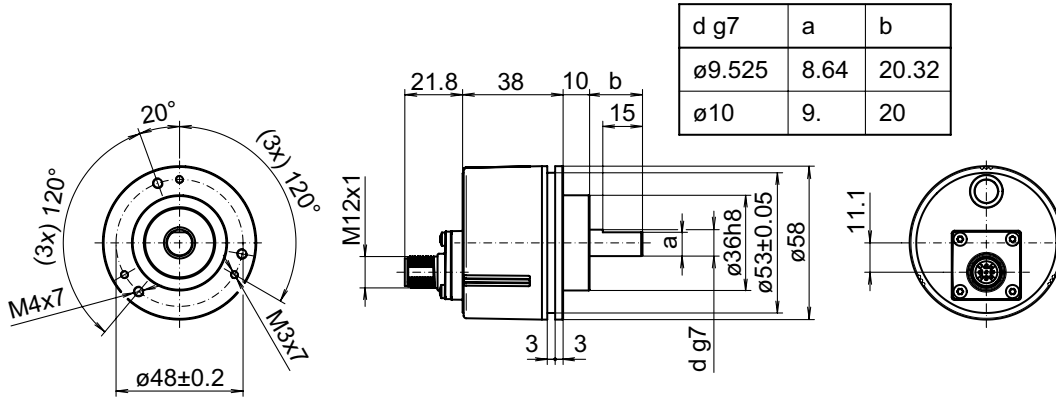

Flange connector M23, axial

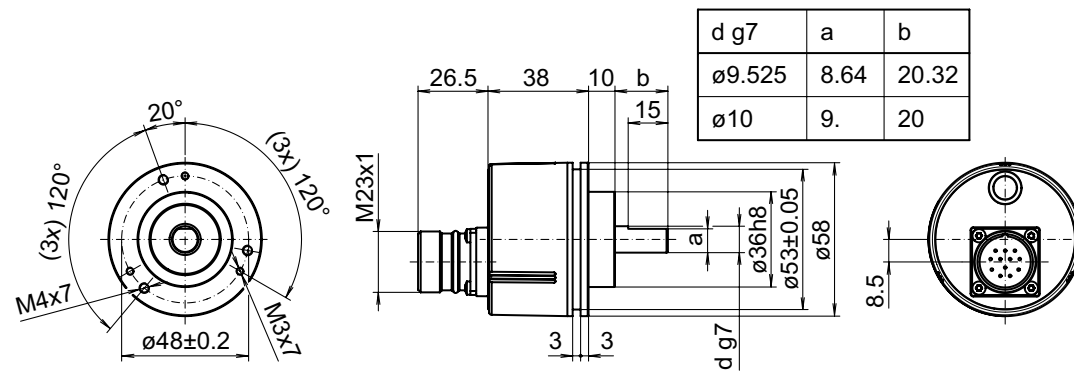

Cable, axial

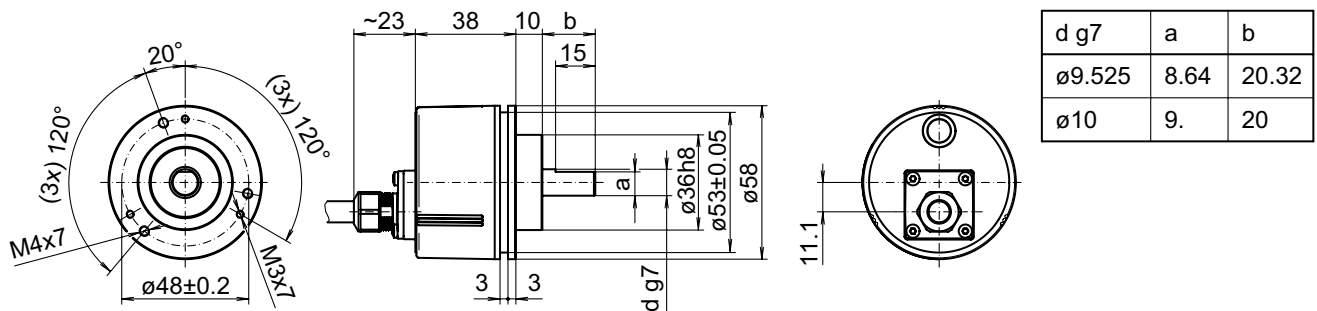

Incremental encoders

Solid shaft with clamping flange

1...65536 pulses per revolution programmable (interpolated system)

ExEIL580P-SC

Dimensions

Cable, tangential

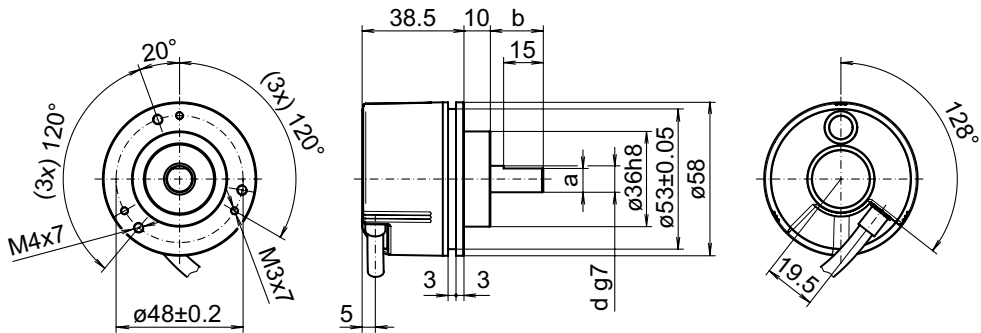

d g7	a	b
ø9.525	8.64	20.32
ø10	9.	20

Incremental encoders

Solid shaft with clamping flange

1...65536 pulses per revolution programmable (interpolated system)

ExEIL580P-SC

Explosion protection

⊕ II 3 D Ex tc III C T135°C Dc X (dust)

General- and Special conditions „X“:

Only put the device into operation if ...

- all necessary precautions have been taken by the operator to make sure device and connector are fully protected against mechanical impacts or shocks in compliance with EN 60079-0, section 26.4.2 (Special conditions „X“).
- the connection is mechanically or electrically secured to prevent any interrupt while the contact is live (Special conditions „X“).
- it has been ensured the electrical connection of product variants with cable outlet or cable couplings is outside zone 22 (Special conditions „X“).
- it has been ensured the maximum operating speed in relation to the ambient temperature is within the specifications on the table „Maximum rotation speed below“ (Special conditions „X“).
- the specifications on the product label match the on-site conditions for use in hazardous areas (EX) (device group, category, zone, temperature class resp. maximum surface temperature).
- the specifications on the product label comply with the prevailing grid conditions.
- the device shows no visible trace of damage (resulting from transport or storage), and
- it has been ensured no explosive atmosphere, oils, acids, gases, vapors, radiation etc. are present during installation.

Observe standard EN 60079-14 for installation and commissioning.

Device operation must observe the installation and operating instructions. The intended use and application of the device comes under the relevant legislation as well as applicable directives and standards.

Maximum rotation speed

	ambient temperature	rotation speed
solid shaft	20 °C	≤ 12000 rpm
	40 °C	≤ 11000 rpm
	60 °C	≤ 8000 rpm
through hollow shaft	20 °C	≤ 6000 rpm
	40 °C	≤ 4500 rpm
	60 °C	≤ 2500 rpm
blind hollow shaft	20 °C	≤ 8000 rpm
	40 °C	≤ 8000 rpm
	60 °C	≤ 5000 rpm