

# Accessories

## Mounting accessories

### Mounting kit 200



#### Features

- Universal torque arm for mounting hole circle 82...108 mm
- Flexible 60° alignment

#### Description

Torque support onto encoder by help of the attached screws. Push encoder onto the drive shaft and mount torque support onto the client side. Fastening clamping ring with clamping ring screw.

#### Part number

11129153 Torque arm, 1-arm open, bolt circle  $\varnothing 82...108$  mm, mounting M4 (mounting kit 200)

#### Scope of delivery

Included:  
torque support, three screws M3 x 6 (DIN 7985 - TX10)

#### Suitable for

EIL580 - blind hollow shaft,  
EIL580 - blind hollow shaft - Option 6301,  
EIL580 - through hollow shaft,  
EIL580 - through hollow shaft - Option 6301,  
EIL580P - blind hollow shaft,  
EIL580P - through hollow shaft,  
ExEIL580 - blind hollow shaft,  
ExEIL580 - through hollow shaft

#### Dimensions

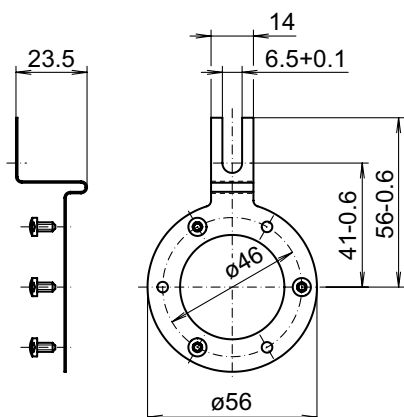

Z01751

#### Assembly drawing

