

Incremental encoders

Solid shaft $\varnothing 11$ mm with EURO flange

1000...6000 pulses per revolution

ITD 41 B10 Y 1



ITD 41 B10 Y 1 with EURO flange

Features

- Encoder with solid shaft $\varnothing 11$ mm
- Max. 6000 pulses per revolution
- Optical sensing method
- Centering alignment $\varnothing 85$ mm, mounting screw hole circle $\varnothing 100$ mm
- Industrial standard with centering flange
- TTL or HTL output signals
- Flange connector radial or axial

Optional

- Extended operating temperature range

Technical data - electrical ratings

Voltage supply	5 VDC ± 5 % 8...30 VDC
Reverse polarity protection	Yes
Consumption w/o load	≤ 100 mA
Pulses per revolution	1000...6000
Reference signal	Zero pulse, width 90°
Sensing method	Optical
Output frequency	≤ 300 kHz (TTL) ≤ 160 kHz (HTL)
Output signals	A, B, N + inverted
Output stages	TTL linedriver (short-circuit proof) HTL push-pull (short-circuit proof)
Interference immunity	DIN EN 61000-6-2
Emitted interference	DIN EN 61000-6-3

Technical data - mechanical design

Size (flange)	$\varnothing 115$ mm
Shaft type	$\varnothing 11$ mm solid shaft
Admitted shaft load	≤ 40 N axial ≤ 60 N radial
Flange	EURO flange B10
Protection DIN EN 60529	IP 65
Operating speed	≤ 12000 rpm
Starting torque	≤ 0.012 Nm (+20 °C)
Materials	Housing: aluminium Shaft: stainless steel
Operating temperature	-20...+70 °C -20...+100 °C
Relative humidity	90 % non-condensing
Resistance	DIN EN 60068-2-6 Vibration 10 g, 55-2000 Hz DIN EN 60068-2-27 Shock 30 g, 11 ms
Connection	Connector M23 type 2, 12-pin
Weight approx.	850 g

Incremental encoders

Solid shaft ø11 mm with EURO flange

1000...6000 pulses per revolution

ITD 41 B10 Y 1

Part number

ITD 41 B10 Y 1

		NI			11	IP65
--	--	----	--	--	----	------

Protection
IP65 IP 65

Flange / Solid shaft
11 EURO flange B10 / ø11 mm

Operating temperature
S -20...+70 °C
E -20...+100 °C

Connection
D2SR12 Flange connector type 2, pin contacts, radial, 12-pin
D2SA12 Flange connector type 2, pin contacts, axial, 12-pin

Output signals
NI A, A inv, B, B inv, 0, 0 inv

Voltage supply / signals
T 5 VDC / TTL level, linedriver
H 8...30 VDC / HTL level, push-pull
R 8...30 VDC / TTL level, linedriver

Pulse number - see table

Pulse number

1000	1440	2048	4000
1024	1500	2500	4096
1200	1800	3000	5000
1250	2000	3600	6000

Accessories

Connectors and cables

11072792	Connector M23 - S2BG12, 1 m cable (incremental)
----------	---

Incremental encoders

Solid shaft $\varnothing 11$ mm with EURO flange
1000...6000 pulses per revolution

ITD 41 B10 Y 1

Output signals

Clockwise rotation when looking at the mounting side.

NI-Output signals

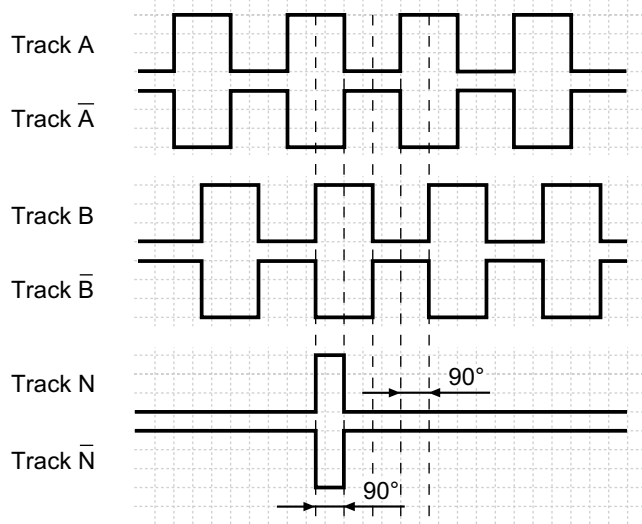

Terminal assignment

Connector	Assignment
Pin 5	Track A
Pin 6	Track A inv.
Pin 8	Track B
Pin 1	Track B inv.
Pin 3	Track N
Pin 4	Track N inv.
Pin 12	UB
Pin 10	GND
Pin 2	UB-Sense
Pin 11	GND-Sense
Pin 9	–
Pin 7	–

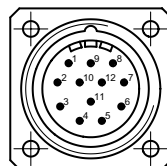

Trigger level

Outputs	Linedriver
Output level High	≥ 2.4 V
Output level Low	≤ 0.5 V
Load	≤ 70 mA

Outputs	Push-pull short-circuit proof
Output level High	$\geq UB - 3$ V
Output level Low	≤ 1.5 V
Load	≤ 70 mA

Subject to modification in technic and design. Errors and omissions excepted.

Incremental encoders

Solid shaft $\varnothing 11$ mm with EURO flange
1000...6000 pulses per revolution

ITD 41 B10 Y 1

Dimensions

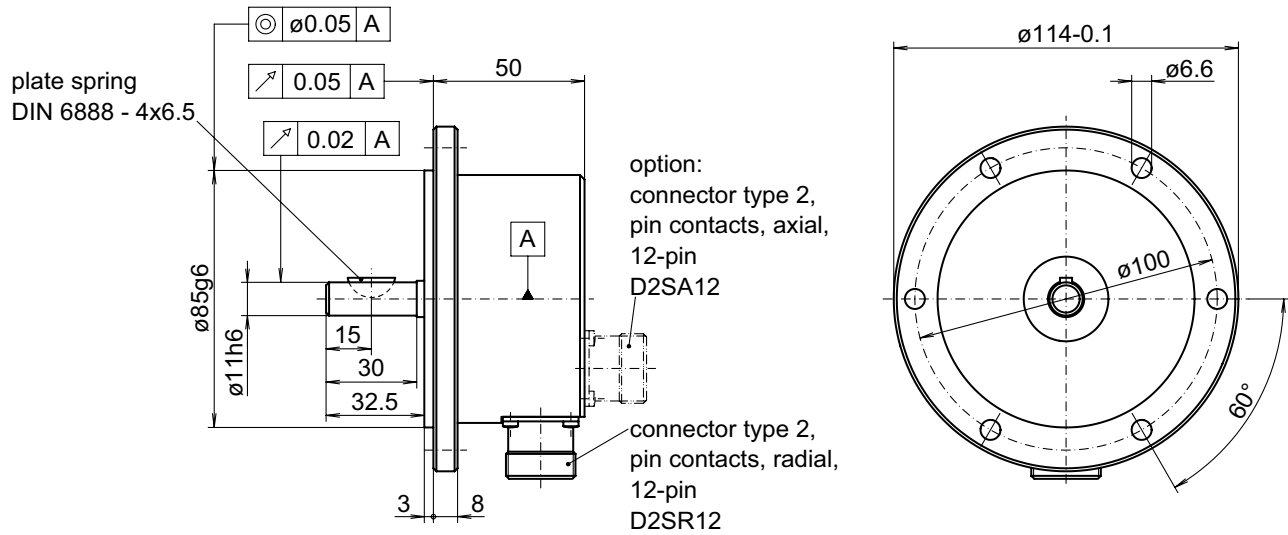

025- 7 Y 1