

Spindle position displays

Through hollow shaft up to $\varnothing 14$ mm, automated format adjustment

Display LCD two lines, interface RS485

N 152



N 152 with cable output

Features

- Automated format adjustment
- Two keys for format adjustment touch by touch
- Through hollow shaft up to $\varnothing 14$ mm
- Resolution: 1440 steps/revolution ± 4096 revolutions
- Display: LCD backlit, two lines
- Absolute multiturn measuring system
- Actual value and target display
- Interface RS485

Technical data - electrical ratings

Voltage supply	24 VDC ± 10 %
Current consumption	≤ 40 mA
Display	LCD, 7-segment display, 2-lines, backlit
Measuring principle	Absolute multiturn measuring system
Measuring range	-99.99...+999.99 mm -9.999...+99.999 inch
Steps per revolution	1440
Number of revolutions	4096 / 12 bit
Spindle pitch	≤ 14 mm
Interface	RS485 (ASCII protocol)
Data memory	Parameter buffer: EEPROM Current value buffer: >10 years by integrated 3 V lithium battery
Programmable parameters	Display position horizontal/vertical Measuring unit mm/inch Counting direction Spindle pitch Spindle tolerance Positioning direction Direction arrows Tolerance window Round up/down
Motive positioning	Two softkeys for format alignment Direct motor connection to N 152 by motor cable
Standard DIN EN 61010-1	Protection class II Overvoltage category II Pollution degree 2
Emitted interference	DIN EN 61000-6-3
Interference immunity	DIN EN 61000-6-2
Approval	UL approval / E63076

Technical data - mechanical design

Shaft type	$\varnothing 14$ mm (through hollow shaft)
Operating speed	≤ 600 rpm (short-term)
Protection DIN EN 60529	IP 50
Operating temperature	-10...+50 °C
Storage temperature	-20...+70 °C
Relative humidity	80 % non-condensing
Torque support	Torque pin provided at housing
Connection	- Cable output (15 cm) with male connector M8, 4-pin - Motor cable with female connector M16, 12-pin
Operation / keypad	Membrane with two keys
Housing type	Surface-mount with hollow shaft
Dimensions	37 x 75 x 45 mm
Mounting type	Directly at shaft end by means of grub screw
Weight approx.	120 g
Material	Polyamide black, UL 94V-0

Spindle position displays

Through hollow shaft up to $\varnothing 14$ mm, automated format adjustment
Display LCD two lines, interface RS485

N 152

Part number					
N 152.	1		3	A	01
				Through hollow shaft A $\varnothing 14$ mm	
				Display A Inclined B Horizontal at front	
			Voltage supply 3	24 VDC	
			<u>Connection</u>		
			1 Cable output M8, motor cable 0.5 m		
			2 Cable output M8, motor cable 1.5 m		
			<u>Interface</u>		
			1 RS485		

Description

multiconDrive represents a simplified and very efficient, reasonably priced system for automatic format adjustment. With multiconDrive the spindle position displays communicate directly with EC motors. Every spindle position display is connected to the corresponding motor by a separate cable output providing the motor without delay with the signals "clockwise", "counterclockwise", "rotation speed" for switchover to high/low speed.

The spindle position display provides two keys for clockwise and counterclockwise direction used during the first editing operation. The key makes the motor moving into the requested direction. A soft touch results in a defined STEP. Thus, new spindle positions can be edited under direct visual check of the operator with an accuracy of $\pm 1/100$ mm. Shaft position parameters once set can be filed as profile in the control. The serial interface enables network of maximum 32 spindle position displays with PC or PLC.

Accessories	
Connectors and cables	
11034330	Adaptor cable between cable connector M8 and female M16, 1 m (Z 178.A01)
10159563	Cable connector M8, 4-pin, without cable with integrated terminating resistor 120 Ω (Z 178.AW1)
10160606	Female connector M8, 4-pin, without cable (Z 178.B01)
10159560	Data and supply cable M8, 5 m (Z 178.D05)
11054456	Extension cable SPA-motor (male/female) M16, 12-pin, 1 m (Z 165.E01)
10160605	Cable connector M8, 4-pin, without cable (Z 178.S01)
10159739	Coupling cable with M8 - M8, 1 m cable (Z 178.V01)
11034339	Y-junction M8, 4-pin, with cable (Z 178.Y02)
11034336	Coupling cable with M8 - M8, 3 m cable (Z 178.V03)
11034337	Coupling cable with M8 - M8, 5 m cable (Z 178.V05)
11034338	Coupling cable with M8 - M8, 10 m cable (Z 178.V10)
10160607	Data and supply cable, $\varnothing 5$ mm, 4 cores, shielded, on 50 m drum (Z 178.050)

Spindle position displays

Through hollow shaft up to $\varnothing 14$ mm, automated format adjustment

Display LCD two lines, interface RS485

N 152

Terminal assignment

SPA – connector, 4-pin

M8 connector Assignment

Pin 1	Tx/Rx-, RS485
Pin 2	Tx/Rx+, RS485
Pin 3	Sensor supply +24 V
Pin 4	Sensor supply 0 V

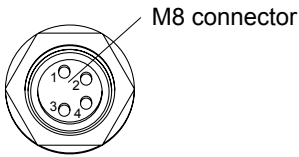

Motor connector, 12-pin

Connector Assignment

Pin A	–
Pin B	Motor left
Pin C	Motor right
Pin D	Speed
Pin E	–
Pin F	–
Pin G	–
Pin H	–
Pin J	–
Pin K	Error signal
Pin L	Speed
Pin M	GND

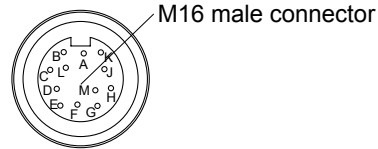

Circuit diagram

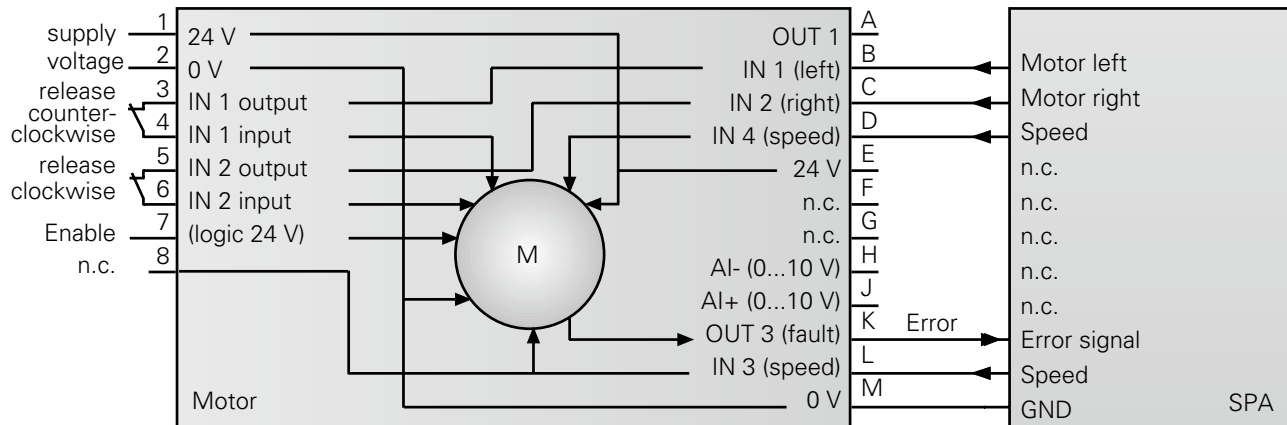

Spindle position displays

Through hollow shaft up to $\varnothing 14$ mm, automated format adjustment
Display LCD two lines, interface RS485

N 152

Dimensions

