

Inductive distance measuring sensors

IR12.D06L-11141090

dimension drawing

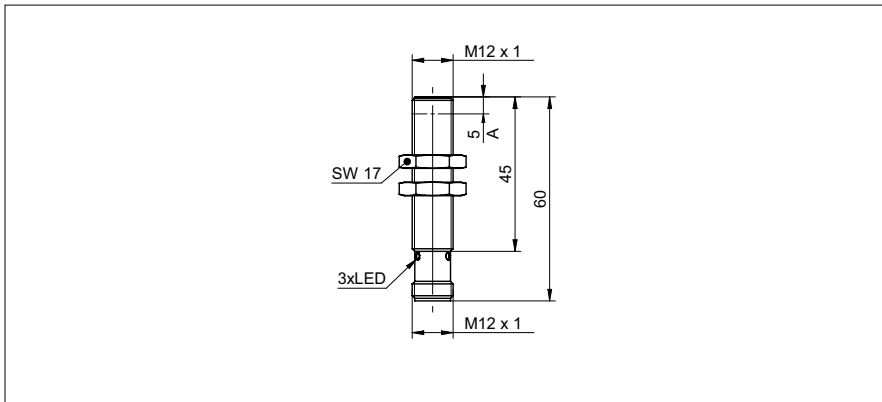

general data

| | |
|-----------------------|--|
| mounting type | quasi-flush |
| special type | linearized |
| measuring distance Sd | 0 ... 6 mm |
| sensitivity | 1,67 V/mm |
| resolution | < 0,003 mm (stat.) < 0,005 mm (dynam., S = 0 ... 4 mm) < 0,022 mm (dynam., S = 0 ... 6 mm) |
| repeat accuracy | < 0,01 mm |
| adjustment | external Teach-in |
| teach | 1-point analog, 2-point analog, factory reset |
| linearity error | ± 25 µm (S = 0 ... 4 mm) ± 60 µm (S = 0 ... 6 mm) |
| temperature drift | ± 2 % (Full Scale; S = 0 ... 4 mm) ± 5 % (Full Scale; S = 0 ... 6 mm) |

electrical data

| | |
|--|----------------|
| response time (factory characteristic) | < 1 ms |
| voltage supply range +Vs | 12 ... 36 VDC |
| current consumption max. (no load) | 15 mA |
| output circuit | voltage output |
| output signal | 0 ... 10 VDC |
| load resistance | > 4000 Ohm |
| short circuit protection | yes |
| reverse polarity protection | yes |

mechanical data

| | |
|------------------------|----------------------|
| type | cylindrical threaded |
| housing material | brass nickel plated |
| dimension | 12 mm |
| housing length | 60 mm |
| connection types | connector M12 |
| tightening torque max. | 15 Nm (A: 10 Nm) |

ambient conditions

| | |
|-----------------------|--|
| operating temperature | -25 ... +75 °C (Vs = 12 ... 30 VDC) -25 ... +60 °C (Vs = 12 ... 36 VDC) |
| protection class | IP 67 |

photo



connection diagram

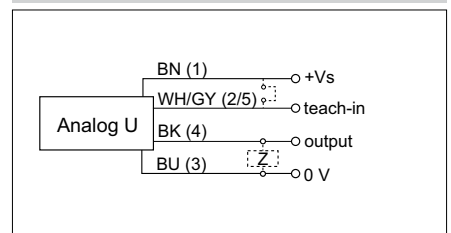

- external Teach-in
- linear analog output