

Absolute encoders - analog

Encoder kit

Magnetic single- or multturn encoders

EAM360R-K - analog - MAGRES



EAM360R Kit with M12

Technical data - electrical ratings

Voltage supply	8...30 VDC 14...30 VDC
Reverse polarity protection	Yes
Consumption typ.	20 mA (24 VDC, w/o load)
Initializing time	≤170 ms after power on
Response time	<1 ms
Interface	Analog 0...10 V / 0.5...4.5 V / 4...20 mA / Resolution: 12 bit
Function	Multiturn, Singleturn
Teach range	5°...359.9° (singleturn), 5°...32767 turns (multiturn)
Absolute accuracy	±0.15 ° (+20 ±15 °C) ±0.25 ° (-40...+85 °C) sensor (see info working distance)
Accuracy analog output	±0.5 % of whole measuring range (-40...+85 °C)
Sensing method	Magnetic
Interference immunity	DIN EN 61000-6-2 ISO 11452-2:2004* / -5:2002* ISO 7637-2:2004* ISO 10605:2008 + Amd 1:2014 (CD ±8 kV / AD ±15 kV) * Severity level according to ECE R10 (Rev. 4)
Emitted interference	DIN EN 61000-6-4 CISPR 25:2008 (30..1000 MHz) ISO 7637-2:2004* * Severity level according to ECE R10 (Rev. 4)
Programmable parameters	Measuring range teachable
Diagnostic function	DATAVALID
Factory setting	360° and 10 revolutions (other on request)

Features

- Encoder kit single- or multiturn / Analog
- ISO 13849 compliant firmware
- E1 compliant design
- High protection up to IP 67
- High resistance to shock and vibrations
- Protection against corrosion C5-M
- Wire cross section 0.5 mm²
- Teach input for adjustment of measuring range

Technical data - mechanical design

Size (flange)	ø36 mm
Shaft type	ø6 mm (magnet bore) ø8 mm (magnet bore) ø12 mm (magnet bore)
Protection DIN EN 60529	IP 67
Operating speed	≤6000 rpm
Working distance	1.1 ±0.9 mm axial / ≤0.3 mm eccentricity
Materials	Housing: steel, powder-coated Flange: aluminium
Corrosion protection	IEC 60068-2-52 Salt mist for ambient conditions C5-M (CX) according to ISO 12944-2
Operating temperature	-40...+85 °C (see general information)
Relative humidity	95 %
Resistance	DIN EN 60068-2-6 Vibration 30 g, 10-2000 Hz DIN EN 60068-2-27 Shock 500 g, 1 ms
Weight approx.	170 g
Connection	Flange connector M12, 5-pin Cable 2 m
Instruction	Use in safety functions exclusively based on Application Note and MTTFD reliability prediction (request separately).

Absolute encoders - analog

Encoder kit

Magnetic single- or multiturn encoders

EAM360R-K - analog - MAGRES

Part number

EAM360R-K W . 7 . . 1 .A

Output characteristics

1 Increasing CW

Measuring range

A360 0°...360°

A36A 0°...3600°

Voltage supply / signals

V3 8...30 VDC / Output 0.5...+4.5 VDC

V1 14...30 VDC / Output 0...+10 VDC

C4 14...30 VDC / Output 4...20 mA

Connection

N Flange connector M12, 5-pin, radial, male contacts, CCW

L Cable 2 m, radial

Protection

7 IP 67

Magnet holder / bore diameter

6 ø6 mm

8 ø8 mm

C ø12 mm

Flange

W Synchro flange, flute ø33 mm, M3

Absolute encoders - analog

Encoder kit

Magnetic single- or multturn encoders

EAM360R-K - analog - MAGRES

Accessories

Connectors and cables

10153968	Female connector M12, 5-pin, straight, without cable
11046266	Female connector M12, 5-pin, straight, shielded, 5 m cable
11144306	Cable with male/female M12, 5-pin, straight, A-coded, 5 m

General information

Self-heating correlated to installation and ambient conditions as well as to electronics and supply voltage must be considered for precise thermal dimensioning. Operating the encoder close to the maximum limits requires measuring the real prevailing temperature at the encoder flange.

For the current output (version C4), a load >470 Ohm must be selected when supplied with 24 VDC in order to minimize the self-heating of the encoder and not to exceed the maximum operating temperature.

For cable lengths >2 m, a current output (version C4) is to be preferred due to the voltage drop in order to avoid effects on the accuracy.

Terminal assignment

Flange connector M12, 5-pin

Pin	Signals	Description
1	0 V	Supply voltage
2	+Vs	Supply voltage
3	Uout/Iout	Analog output
4	DV	DATAVALID output
5	Teach	Teach input

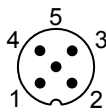

Cable

Core color	Signals	Description
white	0 V	Supply voltage
brown	+Vs	Supply voltage
green	Uout/Iout	Analog output
yellow	DV	DATAVALID output
grey	Teach	Teach input

Cable data: 5 x 0.5 mm²

Terminal significance

Iout	Current output Load: <500 Ω
Uout	Voltage output Current output: max. 10 mA Load resistor: >1 kΩ between Uout / 0 V (version 0...10 V) >2 kΩ (version 0.5...4.5 V)
Teach	Teach in Maximum 0...+Vs Level LOW: <1 V Level HIGH: >2.1 V
DV	Diagnostic output/Teach output Function normal operation: DATAVALID (Diagnostic output) Type NPN output, Pull-Up 10 kΩ integrated - No error: HIGH - Error: LOW Function teach process: Teach status

Absolute encoders - analog

Encoder kit

Magnetic single- or multiturn encoders

EAM360R-K - analog - MAGRES

Output signals

Singleturn

Default: CW, 360°, rotating direction and measuring range teachable.

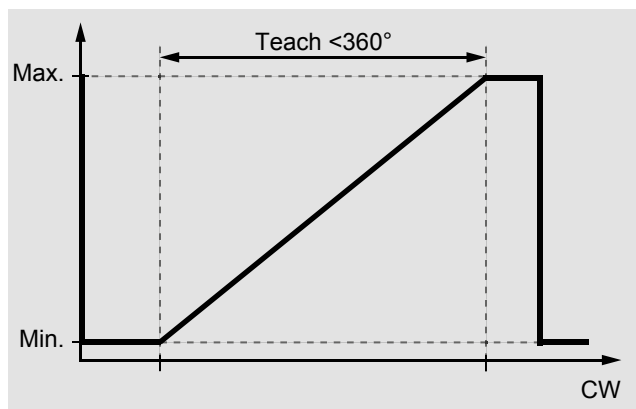
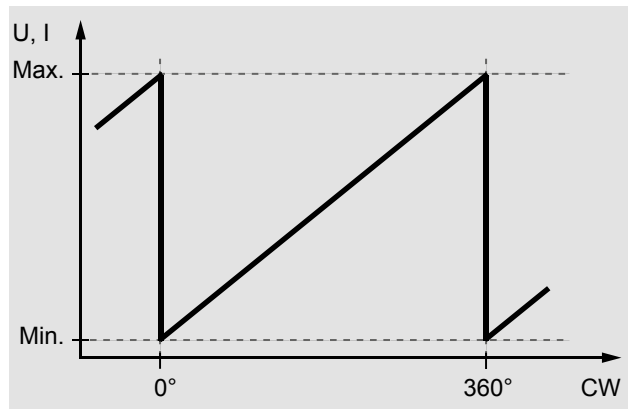

Multiturn

Default: CW, 10 turns, rotating direction and measuring range teachable (max. 32767 turns).

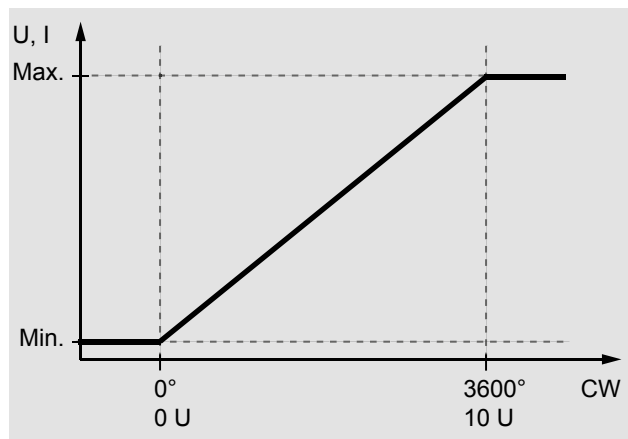

Note: The encoder can be mounted at a specific position and set to position 1 by means of factory preset.

Teach process

Activate teach process

Start teach process within 5 minutes after power on. Set teach input for >5 seconds on HIGH and afterwards on LOW level.

DV/Status output: Oscillates after 5 seconds.

Position 1

Get encoder on position intended for min. voltage output / current output. Set teach input for >0.1 seconds on HIGH. DV/Status output: Switches to HIGH level for 3 seconds and flashes shortly.

Position 2

Get encoder on position intended for max. voltage output / current output. Set teach input for >0.1 seconds on HIGH. DV/Status output: Switches to HIGH level for 3 seconds and flashes shortly. If measuring range is exceeded or the limits are too close to each other, the teaching process was not successful and has to be repeated.

Default

Set teach input for >15 seconds on HIGH.

DV/Status output: Oscillates after 5 seconds.

Working distance

The ideal working distance of the magnet related to the encoder is at an eccentricity of 0 mm and an axial distance of 1.1 mm. Deviation affects the accuracy as shown in following diagram.

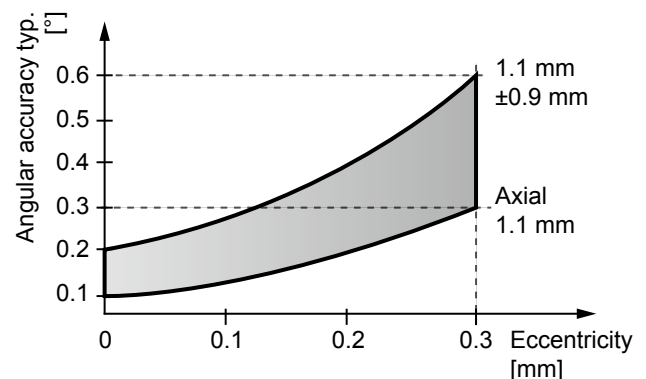

Absolute encoders - analog

Encoder kit

Magnetic single- or multturn encoders

EAM360R-K - analog - MAGRES

Dimensions

EAM360R Kit, cable

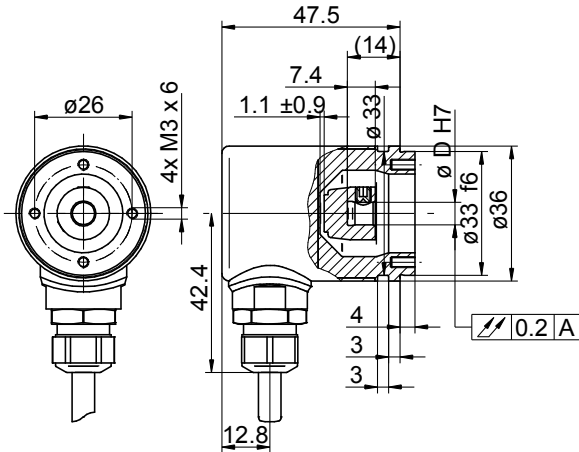

EAM360R Kit, M12

