

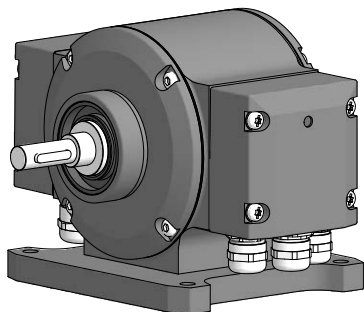

Mounting and operating instructions



PROFI[®]
BUS

microGen
Energy Harvesting

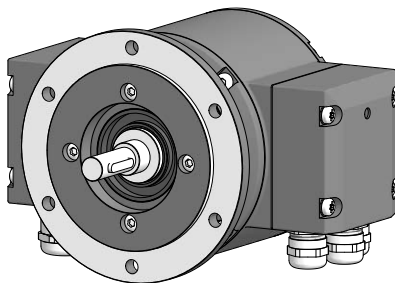
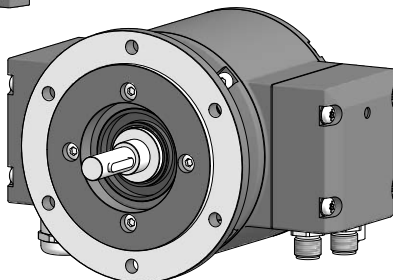

PMG10 • PMG10P
Absolute encoder Profibus DP
with magnetic sensing

TABLE OF CONTENTS

1. IMPORTANT NOTES	1
1.1 Symbol guide	1
1.2 Intended use	1
1.3 Exclusion from liability	1
1.4 Maintenance and service life	2
1.5 Approvals and warranty	2
1.6 Operating and storage temperature range	2
1.7 Disposal (environmental protection)	2
2. SAFETY AND ATTENTION INSTRUCTIONS	3
2.1 Safety instructions	3
2.2 Attention instructions for mounting and operation	4
3. PREPARATION	5
3.1 Scope of delivery	5
3.2 Required accessory for mounting (not included in scope of delivery)	6
3.3 Required tools (not included in scope of delivery)	6
4. MOUNTING	7
4.1 EURO flange B10	7
4.1.1 Mounting the spring disk coupling to the device	7
4.1.2 Mounting to the drive shaft	7
4.1.3 Mounting the spring disk coupling to the drive shaft	8
4.2 Mounting with housing foot B3	9
4.2.1 Mounting the spring disk coupling to the device	9
4.2.2 Mounting to the drive shaft	9
4.2.3 Mounting the housing foot and the spring disk coupling to the drive shaft	10
4.3 Maximum permissible mounting tolerances when the Baumer Hübner K 35 spring disk coupling is used	11
4.4 Note when using a jaw-type coupling (for example „ROTEX®“)	12
5. ELECTRICAL CONNECTION	13
5.1 Profibus DP	13
5.1.1 Features	13
5.1.2 Bus connecting box Profibus DP [A] with cable glands - cable connection	14

5.1.3	Bus connecting box Profibus DP [A] with connectors - assignment connectors	15
5.1.3.1	View A ¹ - connector M12 „Voltage supply“ (male, 4-pin, A-coded)	15
5.1.3.2	View A ² - connector M12 „Data transmission“ (male, 5-pin, B-coded)	15
5.1.3.3	View A ³ - connector M12 „Data transmission“ (female, 5-pin, B-coded)	15
5.1.4	View in bus connecting box Profibus DP [A]	16
5.1.5	Setting for the terminating resistors	16
5.1.6	Setting for the user address	16
5.2	Terminal box [B]	17
5.2.1	Terminal significance	17
5.2.2	Additional output incremental (option)	17
5.2.2.1	Output signals	17
5.2.2.2	Trigger level	18
5.2.3	Programming interface (only PMG10P)	18
5.2.4	LED function displays	18
5.2.5	Switching characteristics speed switch (option)	19
5.2.6	Cable connection	20
5.2.7	Assignment connecting terminal	21
5.3	Accessory Z-PA.SDL.1 <i>WLAN adapter</i> : Programming device for PMG10P	21
6.	DIMENSIONS	22
6.1	EURO flange B10	22
6.2	Housing foot B3	23
7.	DISMOUNTING	24
7.1	EURO flange B10	24
7.2	Housing foot B3	25
8.	TECHNICAL DATA	26
8.1	Technical data - electrical ratings	26
8.2	Technical data - electrical ratings (speed switches)	26
8.3	Technical data - mechanical design	27

1. IMPORTANT NOTES

1.1 Symbol guide



Warning

Disregarding could result in serious injury, death or damage to property



Attention

Disregarding could result in damage to property or damage/malfunction of the device



Information

Additional information and recommendations

1.2 Intended use

The encoder PMG10/PMG10P is a precision measurement device for the acquisition of speed/position information for the control of drive units and the provision of electronic output signals for downstream devices.

The device must not be used for any other purpose. The function of the device is described in this mounting instruction. The customer must check the suitability for the purpose intended.

Mounting and selection must be executed by authorized and qualified personnel. Mounting, electrical commissioning or any other work with the device or system is to be performed by appropriately qualified staff only.

Do not put the device into service if there is any visible evidence of damage.

Do not operate the device beyond the limit values stated in this mounting instruction.

Any risk of personal injury, damage of the system or company equipment due to failure or malfunction of the device must be eliminated by corresponding safety measures.



Warning

Disregarding intended use could result in serious injury or damage to property.

1.3 Exclusion from liability

The manufacturer is not liable for any damage to persons or property resulting from unintended use of the device.

1.4 Maintenance and service life

The device may be only opened as described in this instruction. Repair or maintenance work that requires opening the device completely must be carried out by the manufacturer.

Alterations of the device are not permitted.

The expected service life of the device depends on the ball bearings, which are equipped with a permanent lubrication.

In the event of queries or subsequent deliveries, the data on the device type label must be quoted, especially the type designation and the serial number.

1.5 Approvals and warranty

EU Declaration of Conformity meeting to the European Directives.

We grant a 2-year warranty in accordance with the regulations of the Central Association of the German Electrical Industry (ZVEI).



warranty seal

Damaging the warranty seal on the device invalidates warranty.

1.6 Operating and storage temperature range

The storage temperature range of the device is between -15 °C and +70 °C (caused by packing).

The operating temperature range of the device is between -40 °C and +85 °C, measured at the housing.

1.7 Disposal (environmental protection)



Do not dispose of electrical and electronic equipment in household waste. The product contains valuable raw materials for recycling. Whenever possible, waste electrical and electronic equipment should be disposed locally at the authorized collection point. If necessary, Baumer gives customers the opportunity to dispose of Baumer products professionally. For further information see www.baumer.com.

2. SAFETY AND ATTENTION INSTRUCTIONS

2.1 Safety instructions



Explosion risk

Spark formation can cause a fire or an explosion.

- » Do not use the device in areas with explosive and/or highly inflammable materials. They may explode and/or catch fire by possible spark formation.



Risk of serious injuries due to rotating shafts

Hair and clothes may become tangled in rotating shafts. Touching the rotating parts can cause extremely serious injuries.

- » Before all work switch off all voltage supplies and ensure machinery is stationary.
- » Prevent reconnection voltage supply by third parties.



Risk of serious injuries due to consequential damages

Plants can be deregulated due to malfunction or faulty signals of the device.

- » Damage caused by faulty operation or by a malfunction of the device must be eliminated by corresponding safety measures.



Risk of burns due to formation of heat

The device heats up at higher speed so there is a serious risk of burning shortly after the machine has been turned off.

- » Examine carefully whether the device overheats. Wear suitable gloves if necessary.

2.2 Attention instructions for mounting and operation



Risk of destruction due to electrostatic charge

Electronic parts contained in the device are sensitive to high voltages.

- » Do not touch plug contacts or electronic components.
- » Protect output terminals against external voltages.
- » Do not exceed maximum voltage supply.



Risk of destruction due to mechanical overload

Rigid mounting may give rise to constraining forces.

- » Never restrict the freedom of movement of the device. The mounting instructions must be followed.
- » It is essential that the specified clearances and/or angles are observed.



Risk of destruction due to mechanical shock

Violent shocks, e. g. due to hammer impacts, can lead to the destruction of the sensing system.

- » Never use force. Mounting is simple when correct procedure is followed.
- » Use suitable puller for dismounting.



Risk of destruction due to contamination

Dirt penetrating inside the device can cause short circuits and damage the sensing system.

- » Absolute cleanliness must be maintained when carrying out any work on the device.
- » Never allow lubricants to penetrate the device.



Risk of destruction due to adhesive fluids

Adhesive fluids can damage the sensing system and the ball bearings. Dismounting a device, secured to a shaft by adhesive may lead to the destruction of the device.

- » Do not use adhesive fluids for fixing.

3. PREPARATION

3.1 Scope of delivery

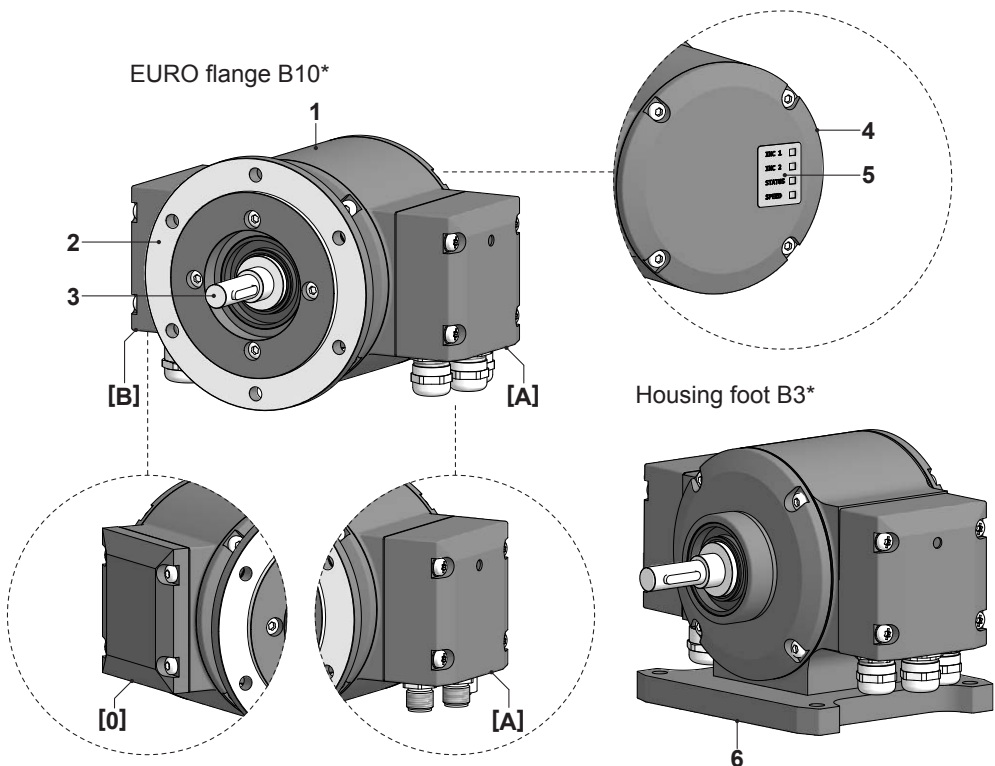

- 1 Housing
- 2 EURO flange B10*
- 3 Solid shaft with key
- 4 Bearing shield
- 5 LED function indicators
- 6 Housing foot B3*

Radial terminal boxes* (see [section 5](#)):

- [A] Bus connecting box Profibus DP
- [B] Additional output incremental (option)
Speed switch (option)
Programming interface (only PMG10P)
- [0] Blind cover - device without additional output, without speed switch and without programming interface

* Depending on version

3.2 Required accessory for mounting (not included in scope of delivery)

i Connecting cables and connectors are required for the electrical connection. Details see *section 5, page 13*.

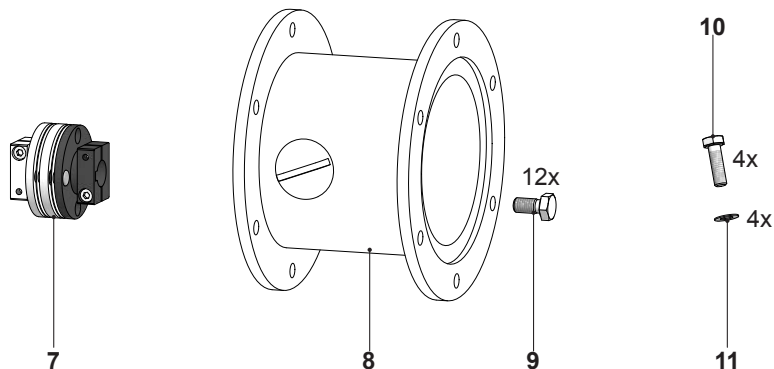

7 Spring disk coupling K 35,
available as accessory, see *section 4.3, page 11*.

For mounting with EURO flange B10

8 Installation fitting, customized

9 Fixing screw M6x16 mm for installation fitting, ISO 4017

For mounting with housing foot B3

10 Fixing screw M6x20 mm for housing foot, ISO 4017

11 Washer B6 for fixing the housing foot, DIN 137

3.3 Required tools (not included in scope of delivery)

⊙ 2.5 mm

○ 10 and 22 mm

✱ TX 10, TX 20

4. MOUNTING

4.1 EURO flange B10

4.1.1 Mounting the spring disk coupling to the device

We recommend using the Baumer Hübner spring disk coupling K 35, see *section 4.3, page 11*, available as accessory. When other couplings are used pay attention to manufacturer's notes.

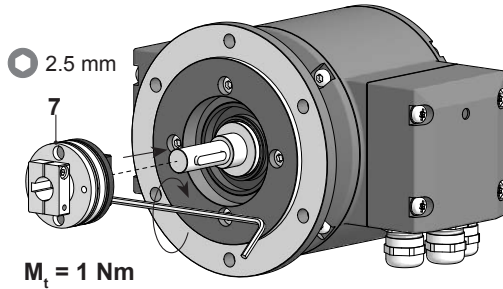

4.1.2 Mounting to the drive shaft

👉 Service life restrictions and angle error by runouts
 High runout of the drive shaft can cause device angle error.
 High runout of the drive shaft can cause vibrations, which can shorten the service life of the device.

- » Lubricate drive shaft!
- » Minimize drive shaft runout ($\leq 0.2 \text{ mm}$; $\leq 0.03 \text{ mm}$ recommended).

i The device must be mounted with cable connection facing downward and not exposed to water.

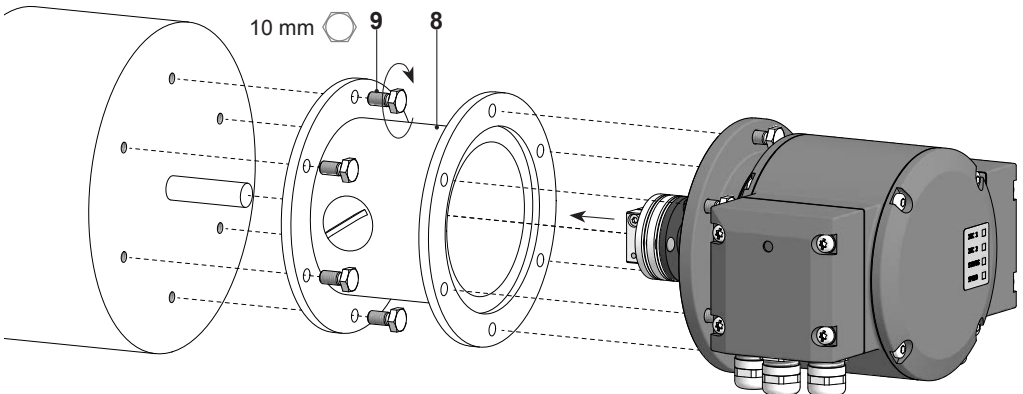

4.1.3 Mounting the spring disk coupling to the drive shaft

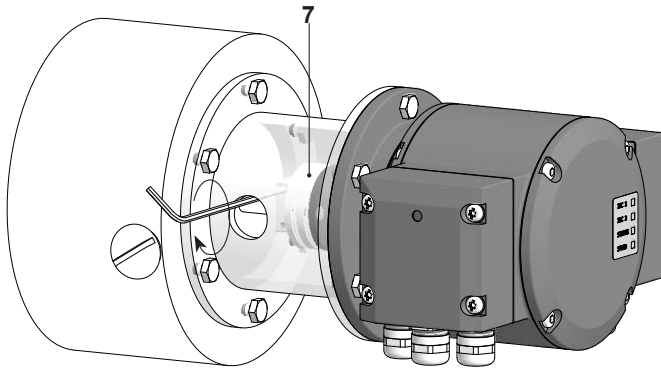

⌀ 2.5 mm

$M_t = 1.3 \pm 10 \% \text{ Nm}$

4.2 Mounting with housing foot B3

4.2.1 Mounting the spring disk coupling to the device

We recommend using the Baumer Hübner spring disk coupling K 35, see *section 4.3, page 11*, available as accessory. When other couplings are used pay attention to manufacturer's notes.

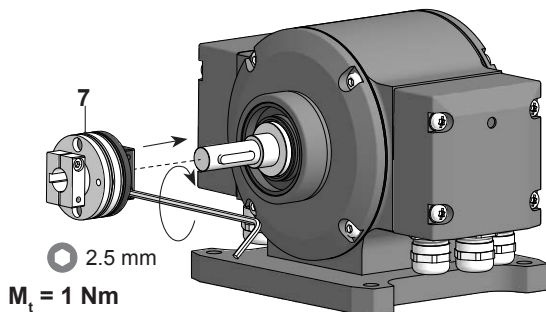

4.2.2 Mounting to the drive shaft

- ☞ Service life restrictions and angle error by runouts
High runout of the drive shaft can cause device angle error.
High runout of the drive shaft can cause vibrations, which can shorten the service life of the device.
- » Lubricate drive shaft!
- » Minimize drive shaft runout ($\leq 0.2 \text{ mm}$; $\leq 0.03 \text{ mm}$ recommended).
- i* The device must be mounted with cable connection facing downward and not exposed to water.

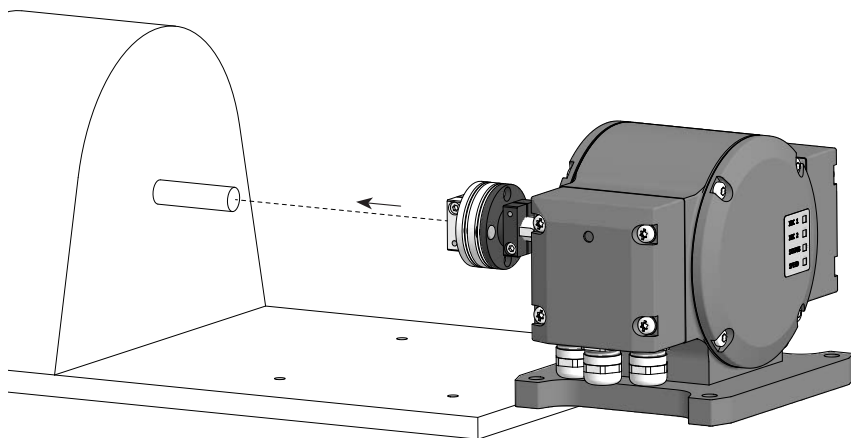

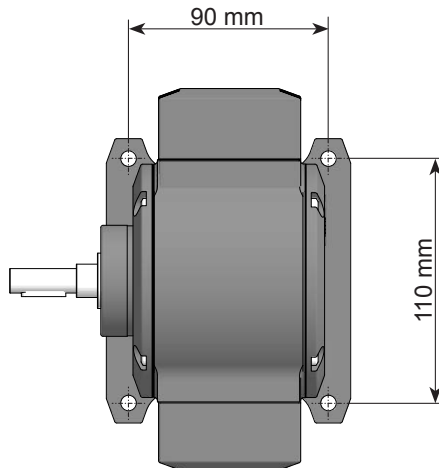
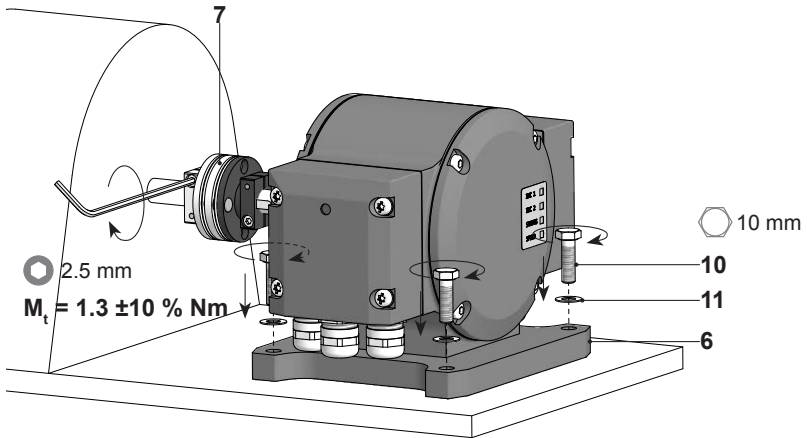

4.2.3 Mounting the housing foot and the spring disk coupling to the drive shaft



4.3 Maximum permissible mounting tolerances when the Baumer Hübner K 35 spring disk coupling is used

Devices with a solid shaft should be driven through the Baumer Hübner K 35 spring disk coupling (accessory), that can be pushed onto the shaft without axial loading.

- i* The figure below shows the device with EURO flange B10, the same maximum permissible mounting tolerances are valid for the device with housing foot B3.
-  The device must be mounted on the drive with the least possible angular error and parallel misalignment.
-  Risk of damaging the ball bearings
Coupling components must not be driven onto the shaft with improper force (e. g. hammer impacts), because of the risk of damaging the ball bearings.

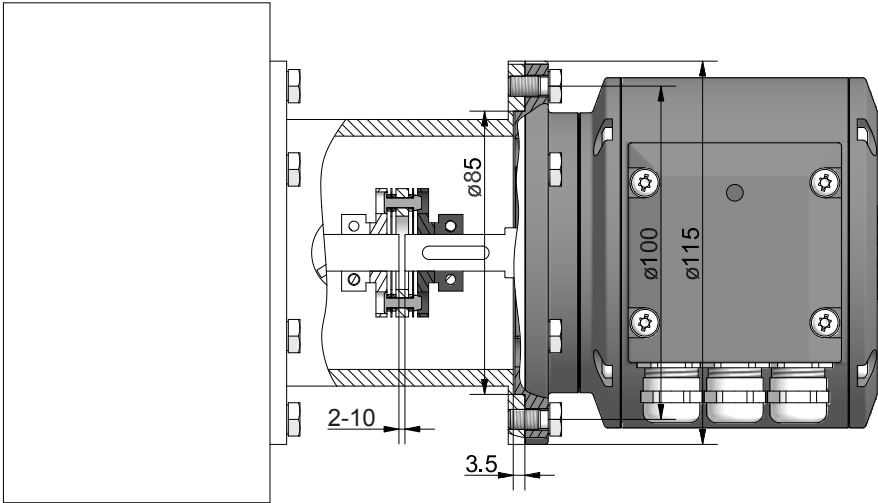

Admissible parallel misalignment

Admissible angular error

Admissible axial movement

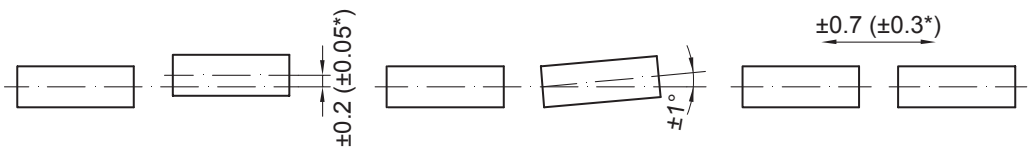

* With insulated hub

All dimensions in millimeters, unless otherwise stated.

4.4 Note when using a jaw-type coupling (for example „ROTEX®“)

✎ Incorrect mounting of the jaw-type coupling can damage the device.
 Avoid blocking of both coupling halves (claws pressed together). The device shaft must not be subjected to direct axial shock.

- » Use a depth gauge to find and observe the correct distances (**L**, **L1**) for the device with EURO flange B10, see below.
- » For the device with housing foot B3 observe the distance **L1**.

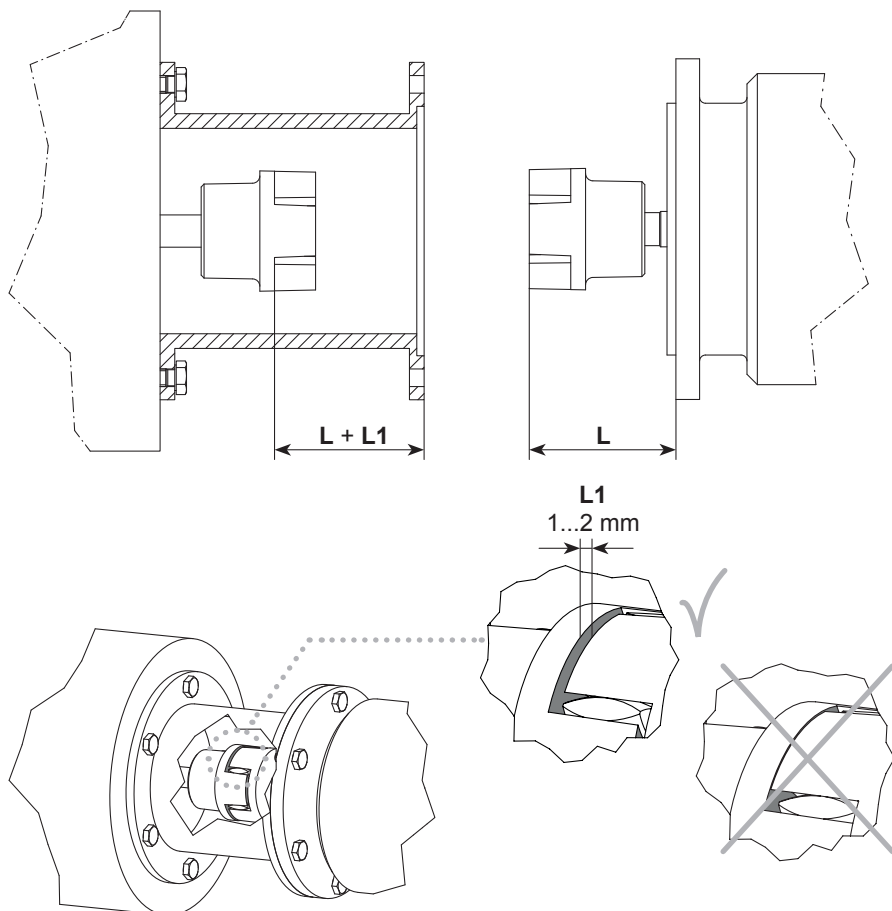

5. ELECTRICAL CONNECTION

5.1 Profibus DP

i Detailed instructions for the Profibus DP V0 interface and the Profibus DP V2 interface, the device description file GSD for Profibus DP V0 and the device description file GSD for Profibus DP V2 can be found on our website www.baumer.com.

5.1.1 Features

Bus protocol	Profibus DP V0* or Profibus DP V2*
Features	Profibus DP V0 = Device Class 1 and 2 Profibus DP V2 = Device Class 3 and 4
Data Exch. functions	Input: Position value Output: Preset value
Preset value	The „Preset“ parameter can be used to set the device to a predefined value that corresponds to a specific axis position of the system.
Parameter functions	Rotating direction: The relationship between the rotating direction and rising or falling output code values can be set in the operating parameter. Scaling: The parameter values set the number of steps per turn and the overall resolution.
Diagnostic	The device supports the following error messages: - Position error
Factory settings	User address 00

* Depending on version

5.1.2 Bus connecting box Profibus DP [A] with cable glands - cable connection

☞ To ensure the specified protection of the device the correct cable diameter must be used.

Connecting cables are not in scope of delivery.

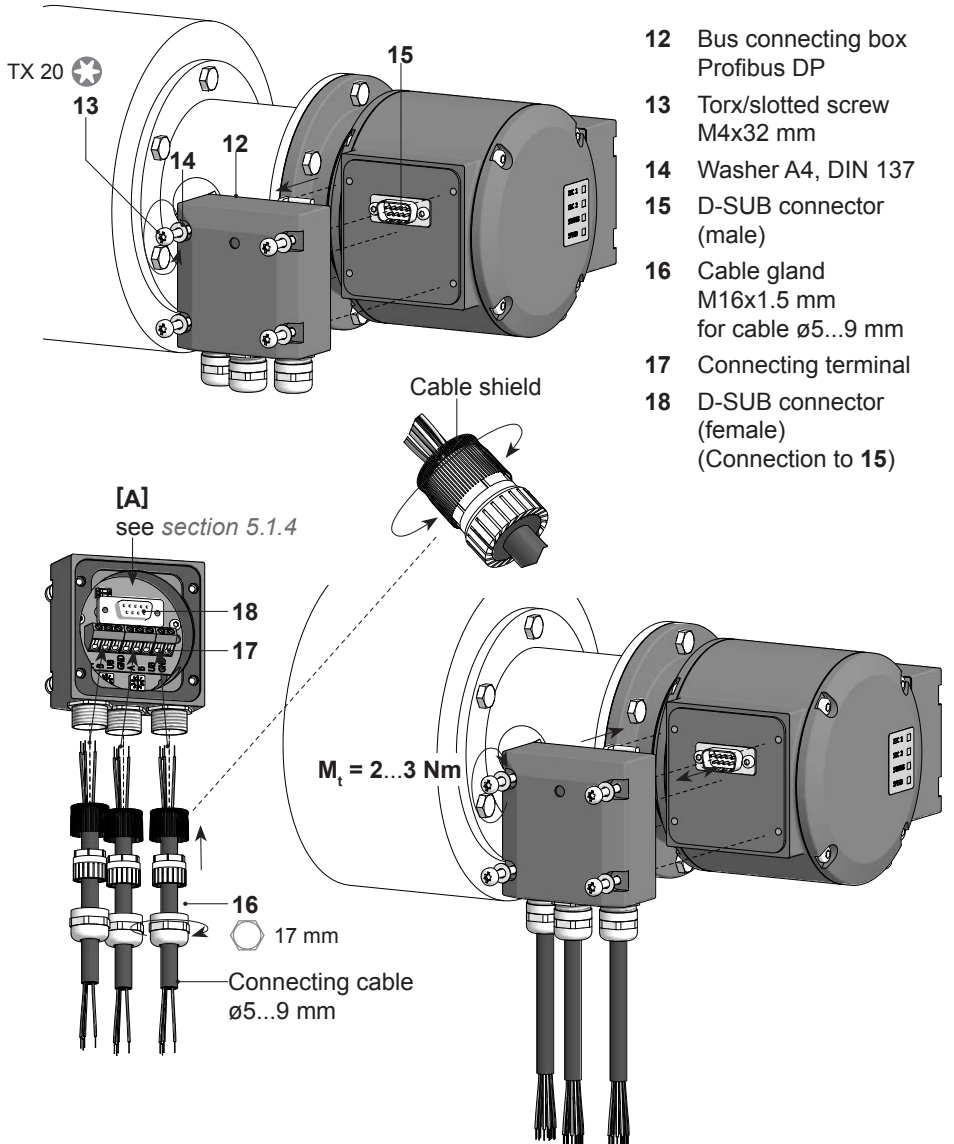

5.1.3 Bus connecting box Profibus DP [A] with connectors - assignment connectors

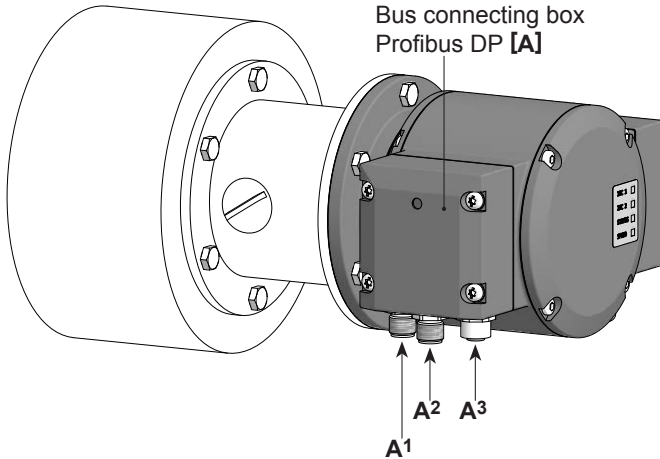

5.1.3.1 View A¹ - connector M12 „Voltage supply“ (male, 4-pin, A-coded)

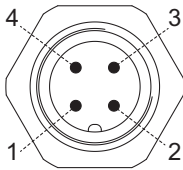

MALE	CONNECTION	DESCRIPTION
1	UB	Voltage supply 10...30 VDC
2	-	Do not use
3	GND	Ground for UB
4	-	Do not use

5.1.3.2 View A² - connector M12 „Data transmission“ (male, 5-pin, B-coded)

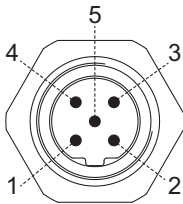

MALE	CONNECTION	DESCRIPTION
1	-	Do not use
2	A	Negative serial data transmission
3	-	Do not use
4	B	Positive serial data transmission
5	-	Do not use

5.1.3.3 View A³ - connector M12 „Data transmission“ (female, 5-pin, B-coded)

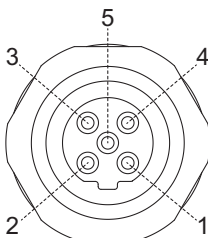

FEMALE	CONNECTION	DESCRIPTION
1	-	Do not use
2	A	Negative serial data transmission
3	-	Do not use
4	B	Positive serial data transmission
5	-	Do not use

5.1.4 View in bus connecting box Profibus DP [A]

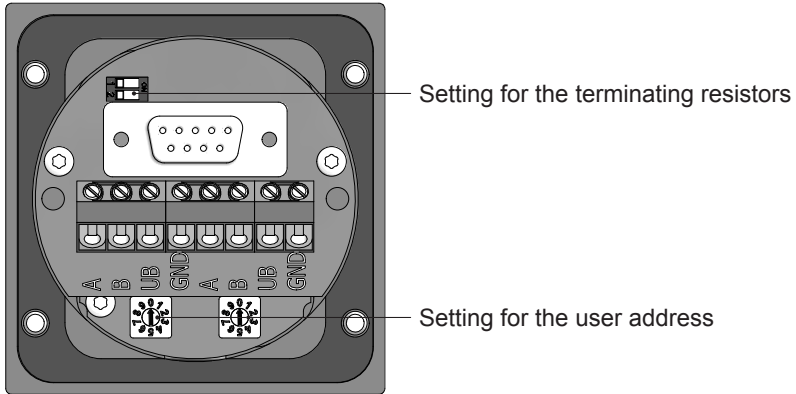

Terminal assignment

- A Negative serial data transmission, pair 1 and pair 2
- B Positive serial data transmission, pair 1 and pair 2
- UB Voltage supply 10...30 VDC
- GND Ground for UB

i Terminals of the same significance are internally connected and identical in their functions. Max. load on the internal terminal connections UB-UB and GND-GND is 1 A each.

5.1.5 Setting for the terminating resistors



ON = Last user

OFF = User xx

5.1.6 Setting for the user address

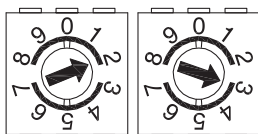

Address can be set by rotary switches. Example: User address 23

5.2 Terminal box [B]

5.2.1 Terminal significance

Ub ¹⁾	Voltage supply
0V ¹⁾	Ground
A+ ¹⁾	Output signal channel 1
A- ¹⁾	Output signal channel 1 inverted
B+ ¹⁾	Output signal channel 2 (offset by 90° to channel 1)
B- ¹⁾	Output signal channel 2 inverted
R+ ¹⁾	Zero pulse (reference signal)
R- ¹⁾	Zero pulse inverted
nE+	System OK+ / error output
nE-	System OK- / error output inverted
SP+ ²⁾	DSL_OUT1 / speed switch (open collector* or solid state relay*)
SP- ²⁾	DSL_OUT2 / speed switch (0V* or solid state relay*)
SA ³⁾	RS485+ / programming interface
SB ³⁾	RS485- / programming interface
dnu	Do not use

5.2.2 Additional output incremental (option)

5.2.2.1 Output signals

At positive rotating direction

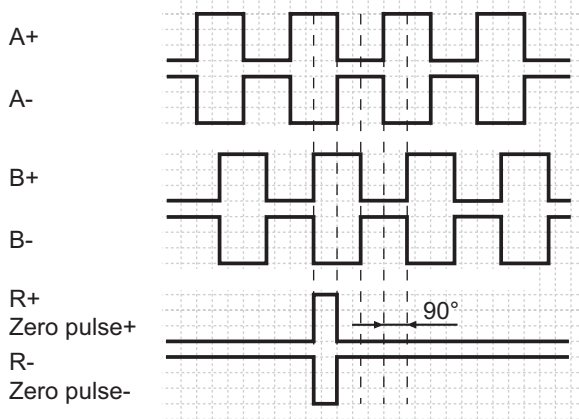

* Depending on version

¹⁾ Additional output incremental (option)

²⁾ Speed switch (option)

³⁾ Programming interface (only PMG10P)

5.2.2.2 Trigger level

Trigger level: TTL/RS422
 High / Low: $\geq 2.5 \text{ V} / \leq 0.5 \text{ V}$
 Transmission length: $\leq 550 \text{ m @ } 100 \text{ kHz}$
 Output frequency $\leq 600 \text{ kHz}$

Trigger level: TTL/HTL (Vin = Vout)
 High / Low: $\geq 2.5 \text{ V} / \leq 0.5 \text{ V (TTL)} \mid \geq U_b - 3 \text{ V} / \leq 1.5 \text{ V (HTL)}$
 Transmission length: $\leq 550 \text{ m @ } 100 \text{ kHz (TTL)} \mid \leq 350 \text{ m @ } 100 \text{ kHz (HTL)}$
 Output frequency $\leq 600 \text{ kHz (TTL)} \mid \leq 350 \text{ kHz (HTL)}$

 Electrically isolated: The TTL/HTL (Vin = Vout) output at the additional output incremental is electrically isolated and requires a separate power supply.

5.2.3 Programming interface (only PMG10P)

Via connection SA and SB, encoder parameters such as additional output, switch-off and switch-on speeds can be changed and read out. With the Z-PA.SDL.1 *WLAN adapter*, available as accessory, see *section 5.3*, the encoder can be accessed via a web browser.

5.2.4 LED function displays

LED	red	green
INC1	Without function	Without function
INC2 (additional output incremental)	Undervoltage Overload Over-temperature	OK
Status	Internal error	OK
Speed	Speed higher switching speed (overspeed)	Speed lower switching speed

5.2.5 Switching characteristics speed switch (option)

i The factory setting of the switching speed for the PMG10P is 6000 rpm. The PMG10 without programming interface is delivered with the individually ordered fixed switching speed.

Event	State of the speed switch output
During initialisation	High resistance (overspeed)
After initialisation and speed $\leq -n_s$ (off)	High resistance (overspeed)
$-n_s$ (off) < speed $\leq -n_s$ (on)	State unchanged Low resistance (no overspeed) after initialisation if the encoder is rotating between the switching range during initialisation.
$-n_s$ (on) < speed < $+n_s$ (on)	Low resistance (no overspeed)
$+n_s$ (on) \leq speed < $+n_s$ (off)	State unchanged Low resistance (no overspeed) after initialisation if the encoder is rotating between the switching range during initialisation.
$+n_s$ (off) \leq speed	High resistance (overspeed)

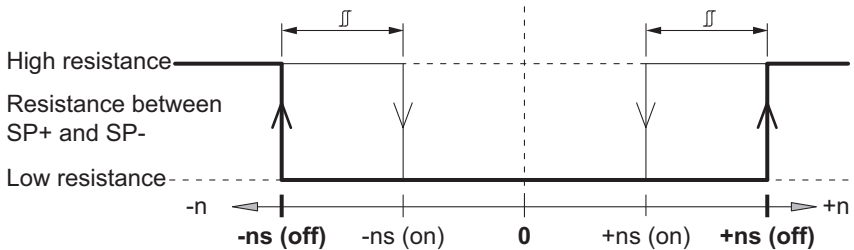

n = Speed

+ns (off) = Switch-off speed at shaft rotation in positive rotating direction*

-ns (off) = Switch-off speed at shaft rotation in negative rotating direction*

Switching hysteresis Δ : 5...100 % (factory setting = 10 % min. 1 Digit)

+ns (on) = Switch-on speed at shaft rotation in positive rotating direction*

-ns (on) = Switch-on speed at shaft rotation in negative rotating direction*

* See section 6, page 22

5.2.6 Cable connection

☞ To ensure the specified protection of the device the correct cable diameter must be used.

Connecting cables are not in scope of delivery.

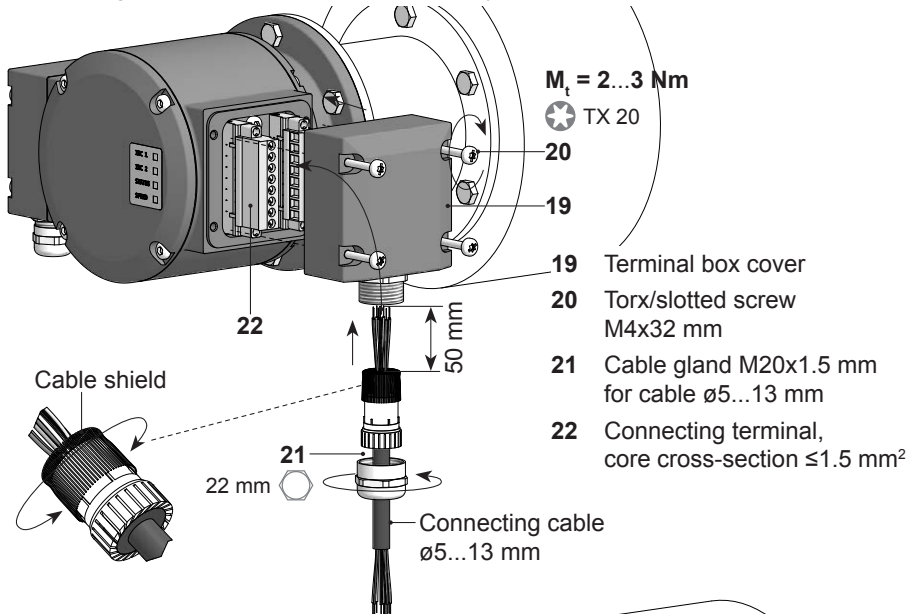

Connecting terminal [B]
 Additional output incremental (option)
 Speed switch (option)
 Programming interface (only PMG10P)
 See section 5.2.7

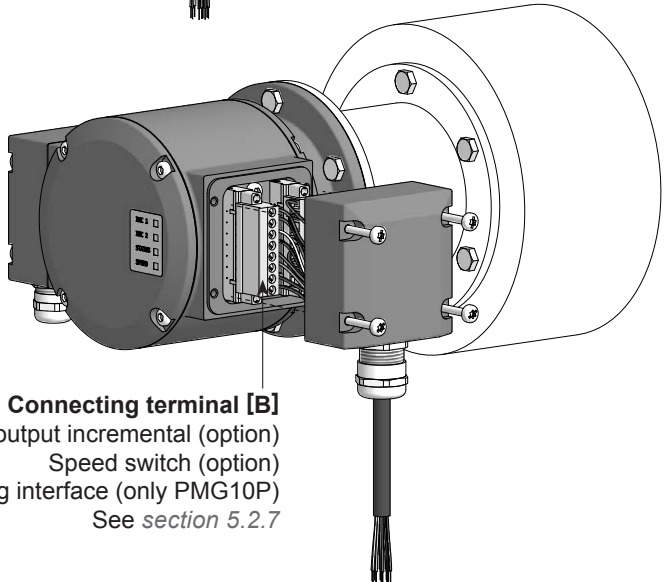

5.2.7 Assignment connecting terminal

- ☞ Do not connect voltage supply to outputs! Danger of damage!
Please, beware of possible voltage drop in long cable leads (inputs and outputs)!
- ☞ The TTL/HTL ($V_{in} = V_{out}$) output at the additional output incremental is electrically isolated and requires a separate power supply.

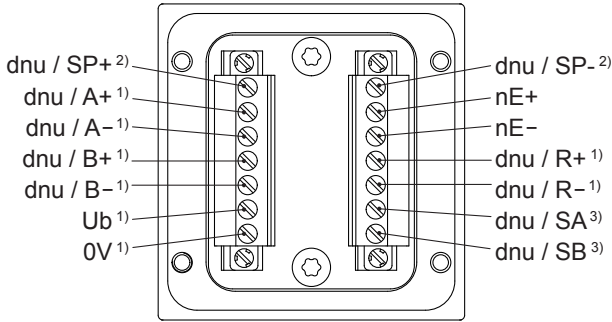

- ¹⁾ Additional output incremental (option)
- ²⁾ Speed switch (option)
- ³⁾ Programming interface (only PMG10P)

5.3 Accessory Z-PA.SDL.1 WLAN adapter: Programming device for PMG10P

The Z-PA.SDL.1 *WLAN adapter* is a programming device for programming and monitoring HMG10P/PMG10P series encoders.

The following encoder parameters can be parameterized (depending on the version of the encoder):

- Additional output 1 and 2 (number of pulses per revolution)
- Switch-off and switch-on speeds

The programming device can be configured and operated via a web browser.

i A detailed description of all available functions can be found in the mounting and operating instructions of the *WLAN adapter*.

Z-PA.SDL.1 *WLAN adapter*

Part number
11190106

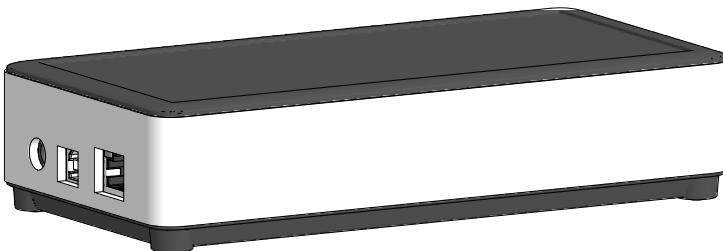

6. DIMENSIONS

6.1 EURO flange B10

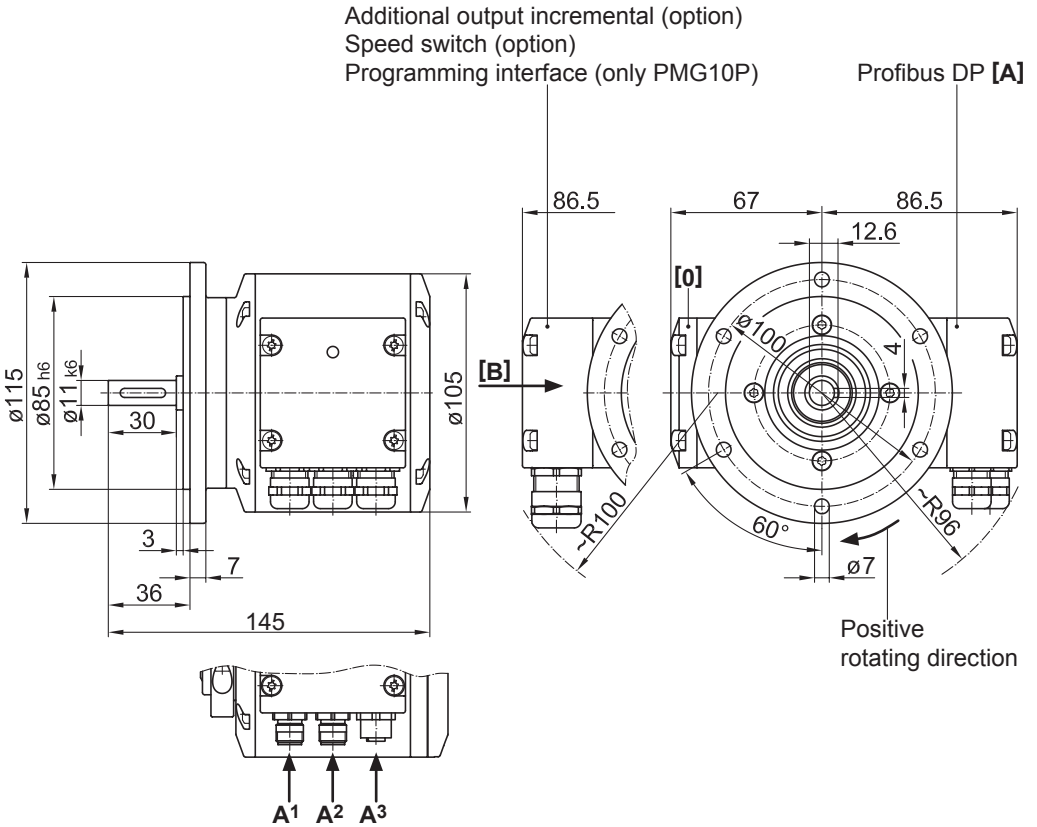

All dimensions in millimeters, unless otherwise stated.

7. DISMOUNTING



Risk of serious injuries

Disconnect all electrical connections before dismounting.

7.1 EURO flange B10

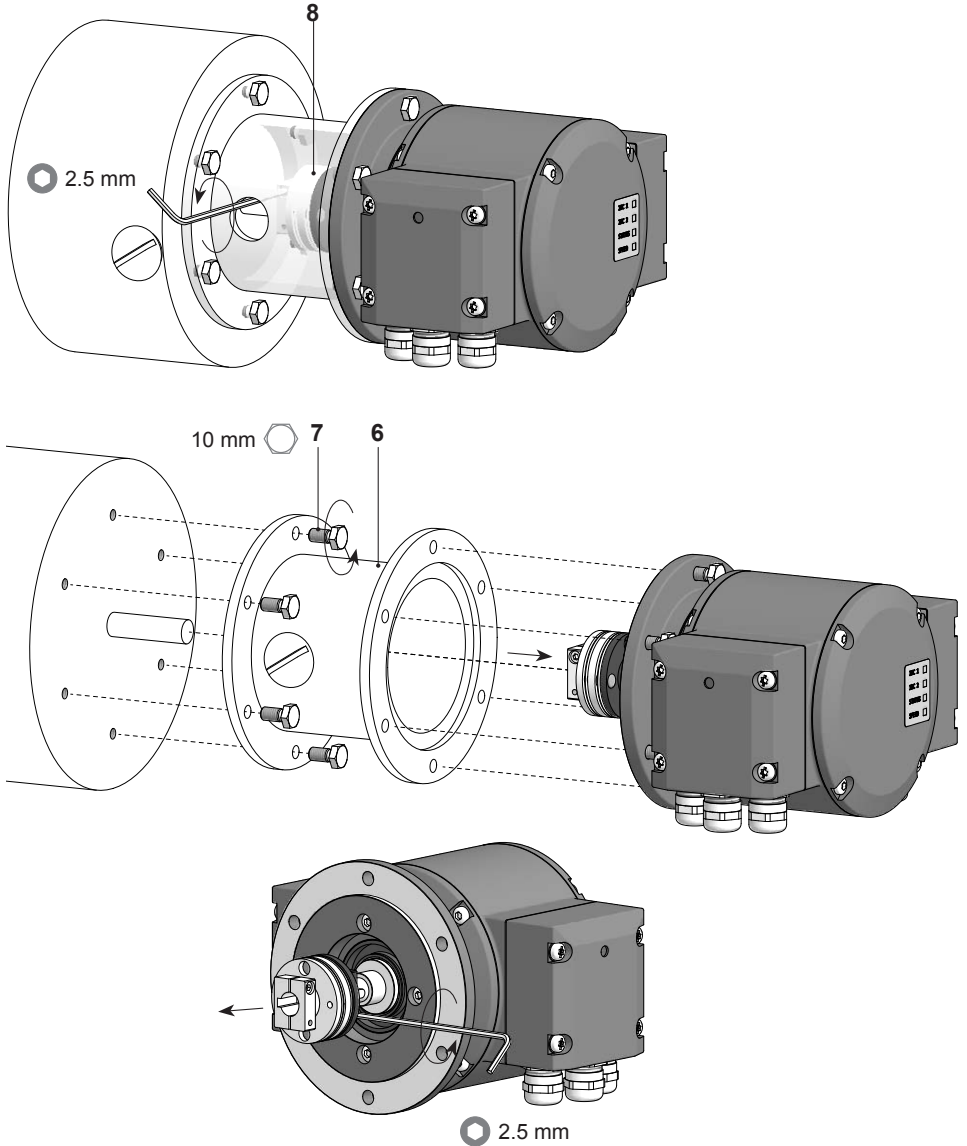

7.2 Housing foot B3

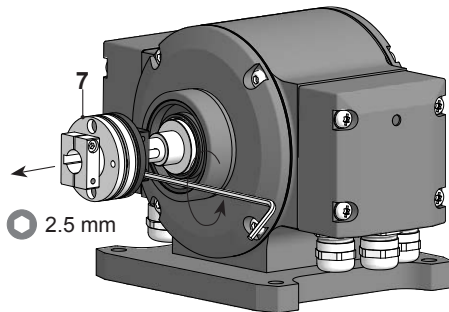
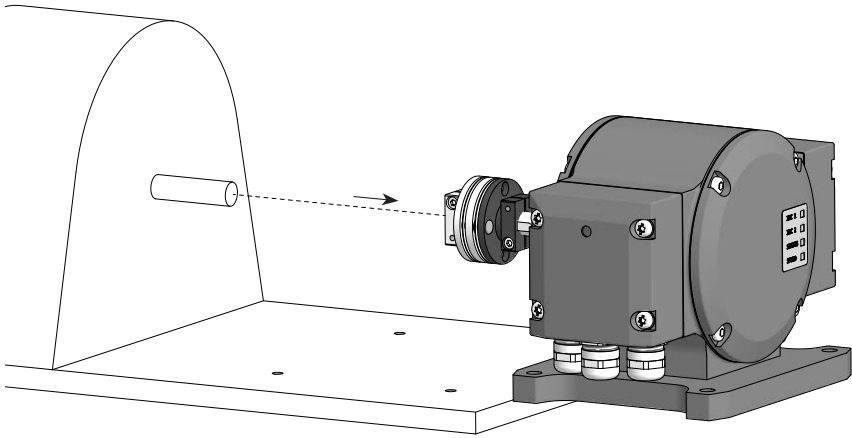
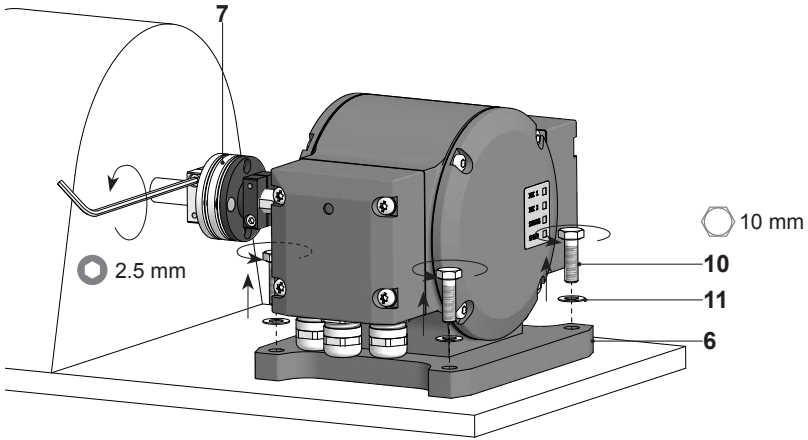

8. TECHNICAL DATA

8.1 Technical data - electrical ratings

Voltage supply	10...30 VDC
Short-circuit proof	Yes
Consumption w/o load	≤200 mA
Initializing time	≤500 ms after power on
Interface	Profibus DP
Transmission rate	9.6...12000 kBaud
Device address	Rotary switches in bus connecting box
Steps per turn	8192 / 13 bit
Number of turns	65536 / 16 bit
Additional outputs	Square-wave TTL/HTL, TTL/RS422
Sensing method	Magnetic
Interference immunity	EN 61000-6-2
Emitted interference	EN 61000-6-3
Programming interface	RS485 (≤600 m) ⁴⁾
Programmable parameters	Bus system: see bus features in <i>section 5.1.1</i> Additional output (number of pulses) ⁴⁾ , switch-off and switch-on speeds ⁴⁾
Diagnostic function	Position or parameter error
Status indicator	DUO-LED in bus connecting box 4 LEDs in device back side
Approvals	CE

8.2 Technical data - electrical ratings (speed switches)

Switching accuracy	±2 % (or 1 Digit)
Switching outputs	1 output (Open collector* or solid state relay*)
Output switching capacity	30 VDC; ≤100 mA
Switching delay time	≤20 ms

* Depending on version

⁴⁾ Only PMG10P

8.3 Technical data - mechanical design

Size (flange)	ø115 mm
Shaft type	ø11 mm solid shaft
Flange	EURO flange B10
Protection DIN EN 60529	IP66/IP67
Operating speed	≤6000 rpm
Range of switching speed	ns (off) = ±2...6000 rpm, (PMG10P: factory setting 6000 rpm)
Operating torque typ.	10 Ncm
Rotor moment of inertia	1 kgcm ²
Admitted shaft load	≤450 N axial ≤650 N radial
Materials	Housing: aluminium alloy Shaft: stainless steel
Operating temperature	-40...+85 °C
Relative humidity	95 % non-condensing
Resistance	IEC 60068-2-6 Vibration 30 g, 10-2000 Hz IEC 60068-2-27 Shock 400 g, 1 ms
Corrosion protection	IEC 60068-2-52 Salt mist complies to ambient conditions CX (C5-M) according to ISO 12944-2
Weight approx.	2.7 kg*
Connection	Bus connecting box Terminal box*

* Depending on version



Baumer

Baumer Hübner GmbH

P.O. Box 12 69 43 · 10609 Berlin, Germany

Phone: +49 (0)30/69003-0 · Fax: +49 (0)30/69003-104

info@baumerhuebner.com · www.baumer.com/motion

Original language of this instruction is German. Technical modifications reserved.