

# USDK 20D9003/S35A

Einwegschranke/  
Sender

Through beam/  
emitter

Barrière simple/  
émetteur



10154485

**Baumer**

Baumer Electric AG · CH-8501 Frauenfeld  
Phone +41 (0)52 728 1122 · Fax +41 (0)52 728 1144

## Abmessungen

Dimensions

Dimensions

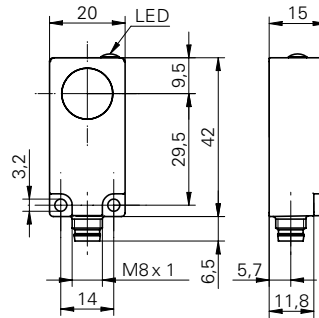

- Alle Masse in mm
- All dimensions in mm
- Toutes les dimensions en mm

## Elektrischer Anschluss

Connection diagrams

Schéma de raccordement

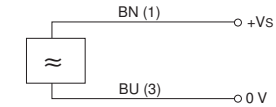

BN = Braun/brown/brun  
BK = Schwarz/black/noir  
BU = Blau/blue/bleu  
WH = Weiss/white/blanc



Anschlussbelegung  
Pin assignment  
Raccordement

- Vor dem Anschliessen des Sensors die Anlage spannungsfrei schalten
- Disconnect power before connecting the sensor
- Mettre l'installation hors tension avant le raccordement du détecteur

## Bedienungsanleitung

Operating instructions

Notice d'utilisation

### Canada

Baumer Inc.  
CA-Burlington, ON L7M 4B9  
Phone +1 (1)905 335-8444

### Italy

Baumer Italia S.r.l.  
IT-20090 Assago, MI  
Phone +39 (0)2 45 70 60 65

### China

Baumer (China) Co., Ltd.  
CN-201612 Shanghai  
Phone +86 (0)21 6768 7095

### Singapore

Baumer (Singapore) Pte. Ltd.  
SG-339412 Singapore  
Phone +65 6396 4131

### Denmark

Baumer A/S  
DK-8210 Aarhus V  
Phone: +45 (0)8931 7611

### Sweden

Baumer A/S  
SE-56133 Huskvarna  
Phone +46 (0)36 13 94 30

### France

Baumer SAS  
FR-74250 Fillinges  
Phone +33 (0)450 392 466

### Switzerland

Baumer Electric AG  
CH-8501 Frauenfeld  
Phone +41 (0)52 728 1313

### Germany

Baumer GmbH  
DE-61169 Friedberg  
Phone +49 (0)6031 60 07 0

### United Kingdom

Baumer Ltd.  
GB-Watchfield, Swindon, SN6 8TZ  
Phone +44 (0)1793 783 839

### India

Baumer India Private Limited  
IN-411058 Pune  
Phone +91 20 66292400

### USA

Baumer Ltd.  
US-Southington, CT 06489  
Phone +1 (1)860 621-2121

Technische Daten  
Technical data  
Données techniques

# USDK 20D9003/S35A

Betriebsspannungsbereich Vs	Voltage supply range Vs	Plage de tension Vs	15-30VDC (UL-Class 2)
Stromaufnahme max. (ohne Last)	current consumption max. (no load)	Consommation max. (sans charge)	<40mA
Max. Laststrom	Max. load current	Courant de charge max.	-
Kurzschlussfest	Short circuit protection	Protégé contre courts circuits	-
Verpolungsfest	Reverse polarity protection	Protégé contre inversion de polarité	ja/yes/oui
Ausgangsanzeige	Output state indication	Indication de l'état de sortie	-
Temperaturbereich	Temperature range	Température de fonctionnement	0...60°C
Schutzklasse	Protection class	Classe de protection	IP67
Erfassungsbereich Sd	Scanning range Sd	Portée de détection Sd	0mm...Sde
Erfassungsbereich-Endwert Sde (pot)	Scanning range far limit Sde (pot)	Valeur final de portée de dét. Sde (pot)	50...1000mm
Schallkeule	Sonic cone profile	Faisceau sonore	(siehe Dok./see doc./consultez doc.)

Weitere Erläuterungen  
General information  
Informations supplémentaires

*Hinweise*  
*Notes*  
*Notes*

- Bei Einsatz in rauer Industrieumgebung 20% Abstandsreserve vorsehen
- Allow 20% reduction in sensing range when used in harsh industrial environments
- Assure une réserve de fonctionnement de 20% lors d'une utilisation dans des environnements difficiles