

# Incremental encoders

## Solid shaft with EURO flange B10

### 300...5000 pulses per revolution

#### POG 11



POG 11

#### Technical data - electrical ratings

Voltage supply	9...30 VDC 5 VDC $\pm$ 5 %
Consumption w/o load	$\leq$ 100 mA
Pulses per revolution	300...5000
Phase shift	90° $\pm$ 20°
Duty cycle	40...60 %
Reference signal	Zero pulse, width 90°
Sensing method	Optical
Output frequency	$\leq$ 120 kHz $\leq$ 300 kHz (on request)
Output signals	K1, K2, K0 + inverted Error output (option EMS)
Output stages	HTL-P (power linedriver) TTL/RS422
Interference immunity	EN 61000-6-2
Emitted interference	EN 61000-6-3
Approvals	CE, UL approval / E256710

#### Features

- Offshore and salt water firm, high protection IP 67
- TTL output driver for cable length up to 500 m
- Very high resistance to shock and vibrations
- EURO flange B10 / solid shaft  $\varnothing$ 11 mm
- Large terminal box, turn by 180°

#### Optional

- Function control with EMS
- Redundant sensing with two terminal boxes
- With heating up to -50°C

#### Technical data - mechanical design

Size (flange)	$\varnothing$ 115 mm
Shaft type	$\varnothing$ 11 mm solid shaft
Admitted shaft load	$\leq$ 300 N axial $\leq$ 450 N radial
Flange	EURO flange B10
Protection DIN EN 60529	IP 67
Operating speed	$\leq$ 12000 rpm (mechanical)
Operating torque typ.	2 Ncm
Rotor moment of inertia	212 gcm <sup>2</sup>
Materials	Housing: aluminium die-cast Shaft: stainless steel
Operating temperature	-40...+100 °C -25...+100 °C (>3072 pulses per revolution) -50...+100 °C (optional)
Resistance	IEC 60068-2-6 Vibration 25 g, 10-2000 Hz IEC 60068-2-27 Shock 300 g, 6 ms
Corrosion protection	IEC 60068-2-52 Salt mist for ambient conditions CX (C5-M) according to ISO 12944-2
Explosion protection	II 3 G Ex nA IIC T4 Gc (gas) II 3 D Ex tc IIIC T135°C Dc (dust)
Connection	Terminal box 2x terminal box (with option M)
Weight approx.	1.9 kg, 2.1 kg (with option M)

# Incremental encoders

## Solid shaft with EURO flange B10

### 300...5000 pulses per revolution

POG 11

#### Part number

#### Incremental encoder

POG11    **DN**

Mounting type  
EURO flange B10  
B3 Housing foot B3

Voltage supply / signals  
I 9...30 VDC / output stage HTL with inverted signals  
TTL 5 VDC / output stage TTL with inverted signals  
R 9...30 VDC / output stage TTL with inverted signals

Pulse number - see table

Output signals  
DN K1, K2, K0

Redundant sensing  
Without redundant sensing  
M With redundant sensing (not possible at version with housing foot B3)

EMS - Enhanced Monitoring System  
Without EMS  
.2 With EMS

#### Pulse number

300	1000	2048	4096
500	1024	2500	5000
512	1200	3072	

Other pulse numbers on request.

#### Accessories

##### Connectors and cables

HEK 8 Sensor cable for encoders

##### Mounting accessories

K 35	Spring washer coupling for solid shaft $\varnothing 6...12$ mm
K 50	Spring washer coupling for solid shaft $\varnothing 11...16$ mm
K 60	Spring washer coupling for solid shaft $\varnothing 11...22$ mm

##### Diagnostic accessories

11075858 Analyzer for encoders HENQ 1100

# Incremental encoders

## Solid shaft with EURO flange B10

### 300...5000 pulses per revolution

## POG 11

### Output signals

At positive rotating direction

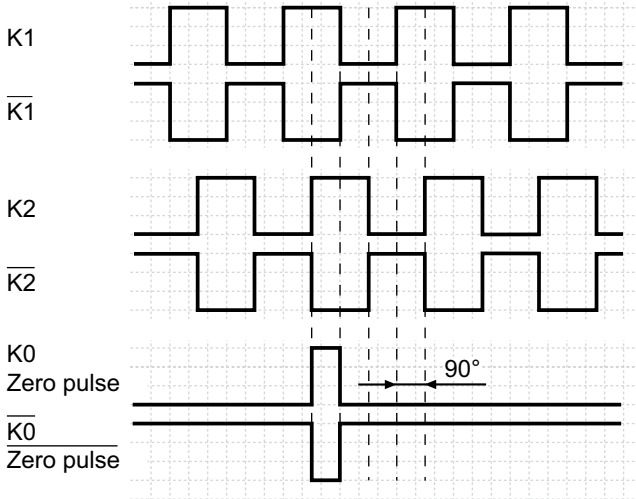

### Terminal significance

+UB	Voltage supply (for the device)
⊥; ↓; GND; 0 V	Ground (for the signals)
⊥; ↗	Earth ground (housing)
K1; A; A+	Output signal channel 1
K1-bar; A-bar; A-	Output signal channel 1 inverted
K2; B; B+	Output signal channel 2 (offset by 90° to channel 1)
K2-bar; B-bar; B-	Output signal channel 2 (offset by 90° to channel 1) inverted
K0; C; R; R+	Zero pulse (reference signal)
K0-bar; C-bar; R-bar; R-	Zero pulse (reference signal) inverted
Err-bar; Err-	Error output (option EMS)
dnu	Do not use

### Terminal assignment

#### View A

Connecting terminal terminal box

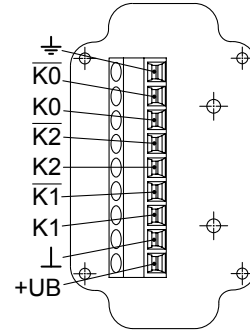

#### Option EMS: View A

Connecting terminal terminal box

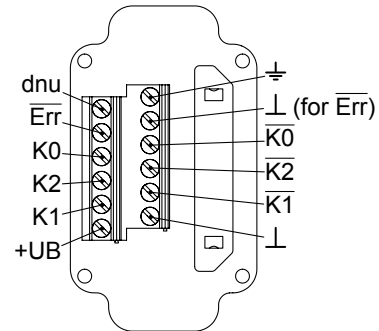

#### Option EMS: LED status / Error output

Flash light red*	Error of signal sequence, zero pulse or pulses (Error output = HIGH-LOW alternation)
Red	Overload output driver (Error output = LOW)
Flash light green	Device o.k., rotating (Error output = HIGH)
Green	Device o.k., stopped (Error output = HIGH)
No light	No voltage supply connection or wrong connection (Error output = LOW)

\* Only at rotating device

# Incremental encoders

## Solid shaft with EURO flange B10

### 300...5000 pulses per revolution

POG 11

#### Dimensions

#### POG 11 (POG 11.2, POG 11 M, POG 11.2 M) - Version with Euro flange (B10)

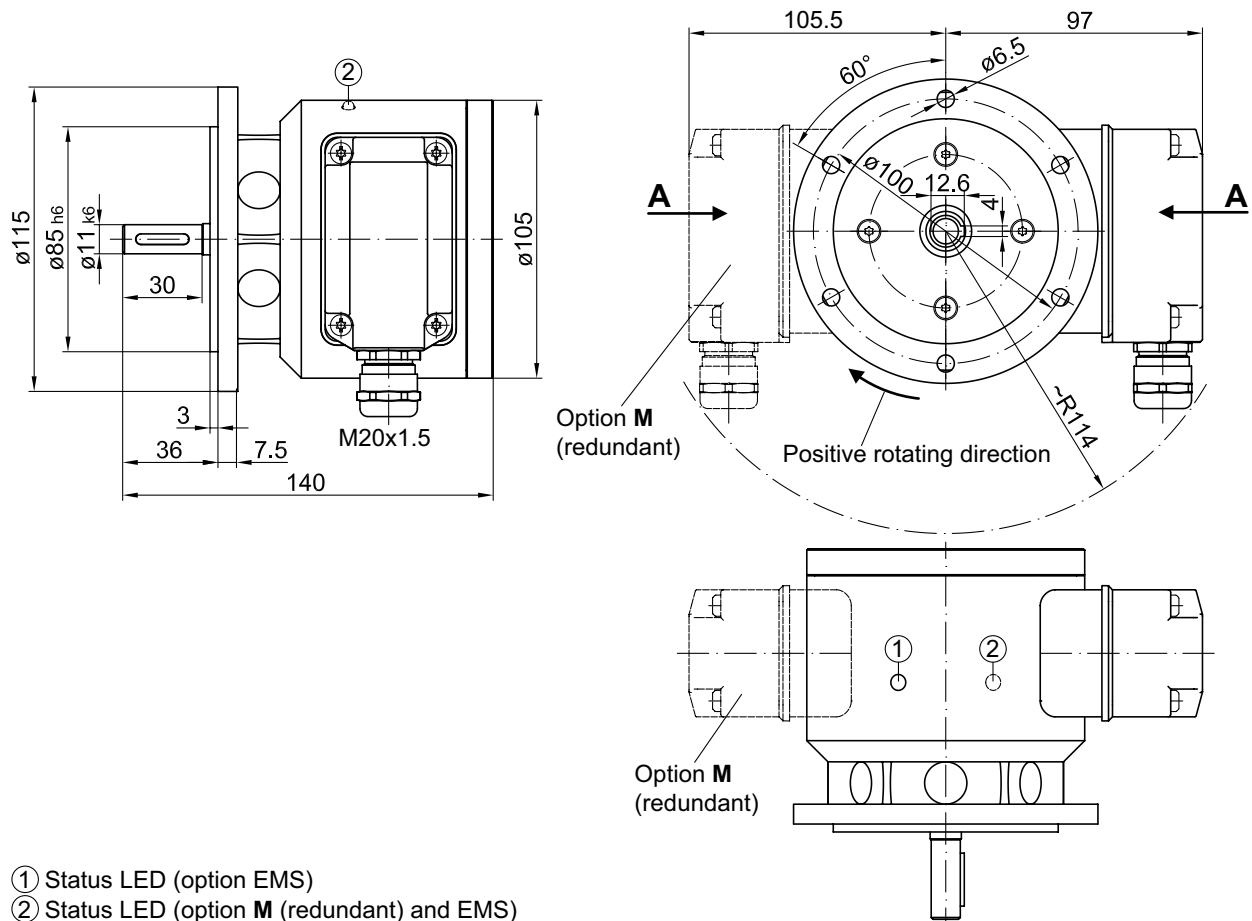

#### POG 11 - Version with housing foot (B3)

