

IO-Link Description

Manual PP20H-D1

V2.1

Last Update: 26 September 2019



Table of Content

1	History	3
2	Abbreviations and Explanations	4
2.1	Abbreviations.....	4
2.2	Explanations.....	4
3	Sensor Covered By This Manual	5
4	IO-Link Introduction	6
4.1	SIO/IO-Link Mode.....	7
4.2	Communication in IO-Link Mode	7
4.3	IO-Link Device Description (IODD).....	8
4.4	Off-Line Parametrisation.....	8
4.5	Digital Measuring Sensors (DMS)	8
5	IO-Link Mode (Sensor Specific Information).....	9
5.1	Process Data.....	9
5.2	Reaction in Case of Failure/Alarm.....	10
6	Function Description.....	12
6.1	Device Access Locks	12
6.2	DeviceProfileID: Smart Sensor Profile.....	13
6.3	DeviceProfileID: Digital Measuring Sensor.....	13
6.4	FunctionClassID: Binary Data Channel	13
6.5	Process Data Input Description	14
6.6	Product Information	14
6.7	Tags	14
6.8	Device Status	15
6.9	Pressure.....	15
6.10	Pressure Switch Point.....	15
6.11	MDC Selector (Pressure/Temperature)	16
6.12	Part Number	17
6.13	Adjustment Of Pressure Process Value.....	17
6.14	Device Temperature	17
6.15	CPU Temperature.....	18
6.16	Time Since Last Power-up.....	18
6.17	Process Temperature	18
6.18	Current Ambient Pressure	19
6.19	Display Control Values.....	19
6.20	MDC Descriptor	19
7	Appendix	21
7.1	Tables.....	21
7.2	Baumer Worldwide	22

1 History

Tab 1 Document History

Vers.	Date	Note
2.1	26 September 2019	Default setting and bit length of the Set Points
2.0	19 July 2019	Upgrade; performance enhancement
1.0	5 July 2019	First release
0.2	20 June 2019	Review feedback (jri, juea, fun, kelro)
0.1	14 June 2019	Initial draft version (sdan, jri)

2 Abbreviations and Explanations

2.1 Abbreviations

• CPU	Central Processing Unit
• DMS	Digital Measuring Sensor
• HMI	Human-Machine-Interface
• ICT	Information and Communication System
• IO	Input/Output
• IODD	IO Device Description
• MDC	Measurement Data Channel
• PLC	Programmable Logic Controller
• RO	Read only: parameter can only be read
• RW	Read/write: parameter can be read and written
• SIO	Standard Input/Output
• SSC1	Switching Signal Channel

2.2 Explanations

Symbols

D1 c/ac	The function is valid for the PP20H-D1 ("D1") and the value is available as <i>cyclic</i> and as <i>acyclic</i> type.
D1 c/-	The function is valid for the PP20H-D1 ("D1") and the function is available only as <i>cyclic</i> type.
D1 -/ac	The function is valid for the PP20H-D1 ("D1") and the function is available as <i>acyclic</i> type.

Main Referenced Documents

Within this manual there are three main documents referenced to:

- *IO-Link Common Profile Specification*, Version 1.0, July 2017, 10.072
- *IO-Link Smart Sensor Profile 2nd Edition Specification*, Version 1.0, March 2017, 10.042
- *IO-Link Interface and System Specification*, Version 1.1.2, July 2013, 10.002

Note

If the alarm bit is set to 1 (= alarm, IO-Link mode) an unreliable state has occurred, all the other SSC are set to low (0) except the process value is recognised as "out of range". This information is especially important, in case the sensor is used in SIO mode. Also here, the SSC mapped to the SIO is set to low (0) except the process value is recognised as "out of range". (See chapter 5.2 *Reaction in Case of Failure/Alarm*, page 10)

3 Sensor Covered By This Manual

This manual applies for all configurations of the PP20H containing the output signal code D1: PP20H-x.xxxxx.D1xx.xxxxxx.xxx¹.

- “D” stands for the output signal combination of the IO-Link channel and the 4 ... 20 mA analogue signal in parallel
- “1” stands for the functional range

¹ Reference is the configurator of the PP20H, see <https://www.baumer.com/ch/p/38450>

4 IO-Link Introduction

IO-Link is an input/output technology standardised worldwide according to IEC 61131-9. It permits manufacturer independent digital, bidirectional point-to-point communication. For this purpose, sensors are connected to the IO-Link master via standardised three-wire plug-in cables. IO-Link is available for various sensor technologies therefore use following link: *Knowledge page*².

With the IO-Link master, which bundles several sensors, the connection to the controller is made via the respective fieldbus system. In addition, an Ethernet-based connection from the master allows direct communication from the sensor to IT systems. IO-Link masters are available as field devices for decentralized mounting or as versions for mounting in control cabinets. Many control suppliers also offer IO-Link input terminals and thus an IO-Link master implemented directly on the control. The maximum cable length between sensor and master is 20 m. However, significantly longer connections from the sensor to the controller can be realized by connecting a field master to a field bus system. This gives them maximum flexibility in the connection solution.

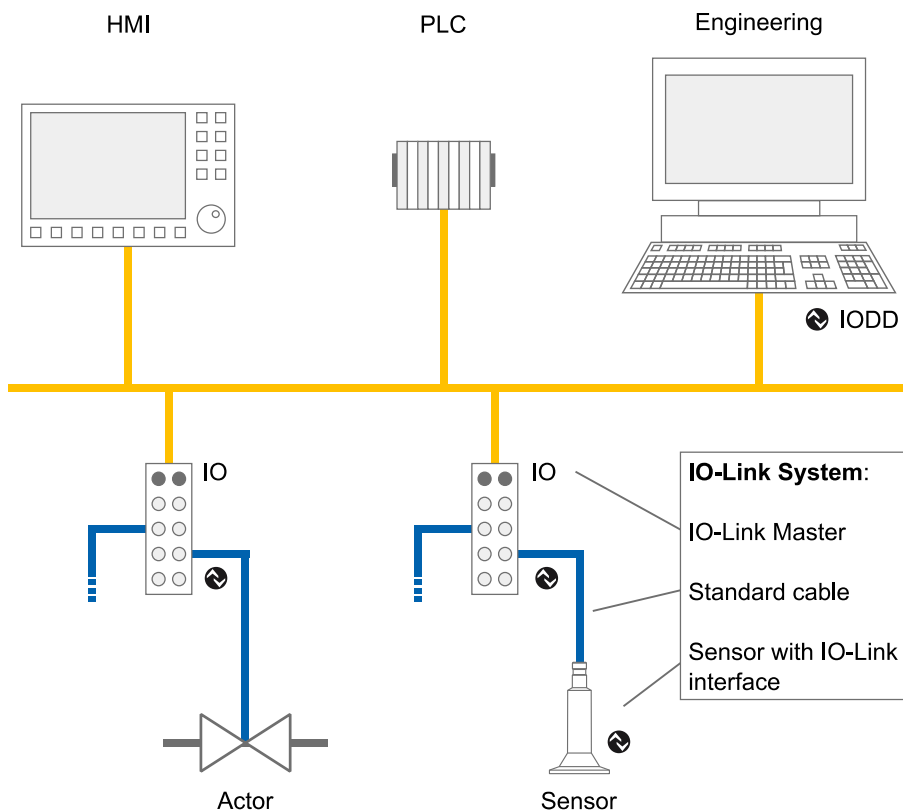

Fig 1 Example of a system architecture using IO-Link

² https://www.baumer.com/de/en/service-support/know-how/technology-highlights/io-link-digitization-begins-with-the-sensor/a/know-how_io-link

4.1 SIO/IO-Link Mode

Each port of the IO-Link master can be operated either in SIO mode or in IO-Link mode. In SIO mode, the SSC mapped to the SIO (push-pull for the PP20H-D1) is used. In IO-Link mode, the output of the sensor is used as a bidirectional, digital interface to exchange measurement and diagnostic information.

4.2 Communication in IO-Link Mode

The communication mode is initiated by the master (PLC) with a standardised command sequence (“wake-up”). After successful completion of the wake-up sequence the IO-link communication starts.

Data is the most important basis for process and product optimisation. With the help of the IO-Link, valuable additional data can be made accessible. Sensor and Master can exchange two different types of data (cyclic and acyclic data). More information can be found *here*³.

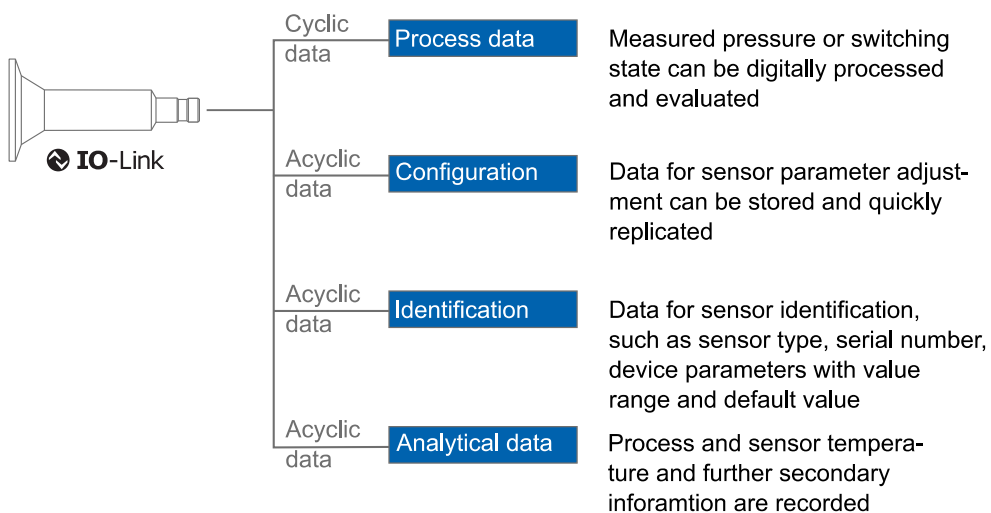

Fig 2 Different IO-Link data streams

- Cyclic data (“c”)

Transmitting in real time with minimum cycle time of 5 ms (reference: IODD from PP20H-D1). They are used for process control in the automation system. These can also be transferred to other ICT systems via IO-Link.
- Acyclic data (“ac”)

Through this data stream, sensors (IO devices) can be parametrised. Additionally this data stream also allows to transmit data for identification and analysis.

³ https://www.baumer.com/de/en/.../know-how_io-link_begriffsbestimmungen

4.3 IO-Link Device Description (IODD)

One or several IO-Link devices with the same interface have their interface described in a xml based file named IO-Link Device Description (IODD). It contains data about the manufacturer, article number, functionality, software version etc. which can be easily read out and further processed by the automation system. Each device, e.g. each sensor, carrying the unique Device ID, matches one IODD with the same Device ID. The identification data of the sensor also includes device or application descriptions that can be freely assigned by the user. The IODD consists of several files: a main file and optional external language files (both in XML format), as well as image files (in PNG format).

4.4 Off-Line Parametrisation

The sensor parameter can be adjusted offline via a user interfaces in the PC (via USB Master) or via a Wireless App (via Wireless Master). Therefore the parametrisation can be conducted rather conveniently at the desk and installed without further teach-in.

Even if IO-Link is not implemented in the machine control (PLC), sensors can be operated in SIO mode (switch) and use the advantage of related parametrisation.

4.5 Digital Measuring Sensors (DMS)

The sensors described in this manual can be operated as “digital measuring sensor” (DMS) according to the Smart Sensor Profile. When treated as DMS the sensors-Master communications happens via a fully standardised command set. Thus operation without IODD file is possible.

5 IO-Link Mode (Sensor Specific Information)

5.1 Process Data

With the sensor in the IO-Link communication mode, process data is cyclically exchanged between the IO-Link master and the device. Process data is exchanged to and from the sensor (Sensor $\leftarrow \rightarrow$ Master).

Process Data-Out (Master to Sensor)

Process Data-Out is sent from the master to the sensor (Sensor \leftarrow Master) and not implemented for the PP20H-D1.

Process Data-In (Sensor to Master)

Process Data-In is sent from the sensor to the master (Sensor \rightarrow Master).

Tab 2 IO-Link Process Data Input

IO-Link Process Data Input									
31 ... 16	15 ... 8	7	6	5	4	3	2	1	Bit 0
Process Value	Scale Exponent	Reserved				Alarm	Reserved		SSC1

The Process Data Input is a 32bit data stream and structured according to the Smart Sensor Profile definition PDI32.INT16_INT8⁴.

- Bit 0: SSC1 (Switching Signal Channel 1)

This bit is the digital representation of a switching output. In chapter 6.10 *Pressure Switch Point*, page 15 further explanations are given (illustration Fig 3, page 16) and especially in Tab 15, page 16, the states of these indexes are shown.

- Bit 3: Alarm

The alarm bit indicates that there is a detectable problem with the configuration or function of the sensor and thus an unreliable state has occurred.

Bit 3 = 0 \rightarrow Sensor operates properly.

Bit 3 = 1 \rightarrow A problem with either the sensor configuration or function was detected.

- Bit 8 ... 15: Scale Exponent

Value is the exponent to the power of ten, applicable to the value of the Measurement Data Channel (MDC). Example for the value of MDC equal to 9.81 bar (the basic unit is Pa):

Process Value is 981

Unit is Pascal (Pa)

Scale is 3 (binary 11)

$981 * 10^3 = 981000 \text{ Pa}$ (equal to 9.81 bar)

⁴ IOL-Smart-Sensor-Profile-2ndEd_V10_Mar2017.pdf

- Bit 16 ... 31: Process Value

In above example it is a value of 981 (binary 1111010101).

5.2 Reaction in Case of Failure/Alarm

Note: If the alarm bit is set to 1 (= alarm, IO-Link mode) an unreliable state has occurred, all the other SSC are set to low (0) except the process value is recognised as “out of range”. This information is especially important, in case the sensor is used in SIO mode. Also here, the SSC mapped to the SIO is set to low (0) except the process value is recognised as “out of range”.

In general

The sensor is provided an easy error handling. In IO-Link mode the alarm bit within the process data indicates an unreliable state of the sensor. Whenever this bit is set, the sensor values could be faulty. The following table roughly shows the behaviour, in case of an failure/alarm, in the IO-Link mode and also in the SIO mode.

Tab 3 Failures and alarms

Description	Reaction	
	IO-Link mode	SIO mode
Process value is out of range	Alarm bit is set to 1. All other SSC are not influenced.	Output is not influenced.
Error in the digital signal path Sensor hardware is faulty	Alarm bit is set to 1. All other SSC are set to 0.	Output is set to low.

Recommended further steps

In IO-Link mode it is possible to locate the problem, in addition to the alarm bit. In most cases, an additional action will be performed by the sensor.

Tab 4 Recommended Further Steps In Case Of Alarm Bit = 1

Cause	Effect	Troubleshooting
	Process value is out of range	
	<p>The process value is set to a standardised value. The value was defined through the IO-Link consortium.</p> <p>If the process value is below the lower limit of the measurement range, it is set to -32760 and if the process value is above the upper limit of the measurement range, it is set to 32760.</p> <p><i>Note:</i> Check all process values, regarding out of range. It may be that one process value is correct, but the other is out of range.</p>	<p>Somewhere a measured value is too low/high. Check your system and may in-crease/decrease the value to be measured. E. g. the measured pressure is too high.</p>

Cause	Effect	Troubleshooting
Error in the digital signal path		
	When an error in the digital signal path occurs, it is not indicated by another feature, only the alarm bit is set.	Disconnect the sensor from the power supply, wait about 5 minutes and restart afterwards the sensor again.
Sensor hardware is faulty		
	When something went wrong with the sensor hardware this is indicated by the IO-Link (detailed) device status (see 6.8 <i>Device Status</i> , page 15). Moreover the process value is set to a standardised value. The value was defined through the IO-Link consortium. When the process value is possibly incorrect, it is set to 32764.	Disconnect the sensor from the power supply, wait about 5 minutes and restart afterwards the sensor again.

6 Function Description

Note

This chapter contains initial information about the different parameter (index and sub-index) while any further details as e.g. the data type have to be taken from the related IODD.

Tab 5 Index 2, System Command

Index	Sub-ind.	Access	Min.	Max.	Default	Meaning
2	0	WO	0	255	-	See IOL-Interface-Spec_10002_V112_Jul13.pdf ⁵ , chapter B2.2, for further information. A noteworthy system command is "Restore factory settings", for this write 130 to the index. <i>Note:</i> A factory reset of the sensor activates the default parameters as programmed in the factory. All parameters changed by the user will be lost.

6.1 Device Access Locks

D1 -ac

This function is in accordance to the IO-Link Interface and System Specification, Version 1.1.2, July 2013, 10.002, chapter B.2.4 [6].

Tab 6 Index 12, Device Access Locks

Index	Sub-ind.	Access	Min.	Max.	Default	Meaning
12	0	RW	-	-	0	Device Access Locks (Only Data Storage Locks is in use)

Tab 7 Available Device Access Locks possibilities

Availability	Bit	Category	Definition
Not available	0	Parameter (write) access (optional)	0: unlocked (default) 1: locked
Available	1	Data Storage (mandatory if the Device supports Data Storage)	0: unlocked (default) 1: locked (see Note)
Not available	2	Local parameterisation (optional)	0: unlocked (default) 1: locked
Not available	3	Local user interface (optional)	0: unlocked (default) 1: locked
	4 ... 15	Reserved	

Note: The Master reads the parameter State_Property/State of Data Storage prior to any actions⁷.

⁵ IOL-Interface-Spec_10002_V112_Jul13.pdf

⁶ IOL-Interface-Spec_10002_V112_Jul13.pdf

⁷ See table B.10 in the IO-Link Interface and System Specification

6.2 DeviceProfileID: Smart Sensor Profile

D1 -/ac

In accordance to the IO-Link Common Profile Specification, Version 1.0, July 2017, 10.072, chapter 5.4 [⁸].

Tab 8 Index 13, DeviceProfileID: Smart Sensor Profile

Index	Sub-ind.	Access	Min.	Max.	Default	Meaning
13	1	RO	-	-	0x0001	DeviceProfileID: Smart sensor profile

6.3 DeviceProfileID: Digital Measuring Sensor

D1 -/ac

In accordance to the IO-Link Smart Sensor Profile 2nd Edition Specification, Version 1.0, March 2017, 10.042, chapter 8.1 [⁹].

Tab 9 Index 13, DeviceProfileID: Digital Measuring Sensor, SSP 3.4

Index	Sub-ind.	Access	Min.	Max.	Default	Meaning
13	2	RO	-	-	0x000A	DeviceProfileID: Digital measuring sensor (DMS, SSP 3.1)

6.4 FunctionClassID: Binary Data Channel

D1 -/ac

In accordance to the IO-Link Smart Sensor Profile 2nd Edition Specification, Version 1.0, March 2017, 10.042, chapter A.1 [¹⁰].

Tab 10 Index 13, FunctionClassID: Binary Data Channel

Index	Sub-ind.	Access	Min.	Max.	Default	Meaning
13	3	RO	-	-	0x8001	FunctionClassID: Binary data channel

⁸ *IOL_Common-Profile_V10_Jul2017.pdf*

⁹ *IOL-Smart-Sensor-Profile-2ndEd_V10_Mar2017.pdf*

¹⁰ *IOL-Smart-Sensor-Profile-2ndEd_V10_Mar2017.pdf*

6.5 Process Data Input Description

D1 -/ac

In accordance to the IO-Link Common Profile Specification, Version 1.0, July 2017, 10.072, chapter B.5 [1].

Tab 11 Index 14, Process Data Input Description

Index	Sub-ind.	Access	Min.	Max.	Default	Meaning
14	1	RO	-	-	0x03 0x10 0x10	Data Type: 0x03 = "IntegerT" TypeLength: 0x10 = 16 bits Bit Offset: 0x10 = 16 bits
14	2	RO	-	-	0x03 0x08 0x08	Data Type: 0x03 = "IntegerT" TypeLength: 0x08 = 8 bits Bit Offset: 0x08 = 8 bits
14	3	RO	-	-	0x01 0x08 0x00	Data Type: 0x01 = "Set of BoolT" TypeLength: 0x08 = 8 bits Bit Offset: 0x00 = 0 bits

6.6 Product Information

D1 -/ac

Different information about the vendor Baumer and the product PP20H are stored on the device as such.

Tab 12 Index 16 ... 23, Product Information

Index	Sub-ind.	Access	Min.	Max.	Default	Meaning
16	0	RO	-	-	Baumer Electric AG	Vendor Name
17	0	RO	-	-	<i>www.baumer.com</i>	Vendor Text
18	0	RO	-	-	PP20H-x.xxxxx.D1xx.xxxxx.xxx	Product Name
19	0	RO	-	-	PP20H-x.xxxxx.D1	Product ID
20	0	RO	-	-	Pressure Sensor	Product Text
21	0	RO	-	-	12 Zeros (0)	Serial Number
22	0	RO	-	-	01.00.00	Hardware Version
23	0	RO	-	-	01.00.00	Firmware Version

6.7 Tags

D1 -/ac

The different tags are enabling the sensor user to identify in the PP20H within its system in an easy way. The three elements application specific, function, and location tag are available. Following example shall illustrate how they can be used:

- Application specific tag: 100321 (example of a measuring location identification number)
- Function tag: Filling height of the tank

¹¹ IOL_Common-Profile_V10_Jul2017.pdf

- Location tag: Tank 3, floor 5

Tab 13 Index 24 ... 26, Tags

Index	Sub-ind.	Access	Min.	Max.	Default	Meaning
24	0	RW	-	-	32 Stars (*)	Application Specific Tag
25	0	RW	-	-	32 Stars (*)	Function Tag
26	0	RW	-	-	32 Stars (*)	Location Tag

6.8 Device Status

D1 -/ac

For diagnosis purpose the IO-Link standard provides the device and detailed device status. In case of the PP20H-D1 both status provides two states and interacts exactly synchronic. More information about the status can be found in the IO-Link Interface and System Specification, Version 1.1.2, July 2013, 10.002, chapter B.2.18 and B.2.19 [12].

Tab 14 Index 36/37, Device Status

Index	Sub-ind.	Access	Min.	Max.	Default	Meaning
36	0	RO	-	-	-	Device Status 0x00: Device is in operation properly 0x04: Failure
37	0	RO	-	-	-	Detailed Device Status 0x00 0x00 0x00: No Error/Warning 0xF4 0x500x10: Component malfunction, repair or exchange

6.9 Pressure

D1 c/-

Main pressure measurement value in Pascal (Pa) after calculating with scale exponent. Filtering is not available.

6.10 Pressure Switch Point

D1 -/ac

- IO-Link standardised name: SSC1 (Switching Signal Channel)
- In SIO mode the SSC1 is mapped to the SIO.
- Set points are settable in the specified pressure ranges (see 6.20 MDC Descriptor).
- Set points cannot be set on each other so they cannot have the same value.
- Only the two-point mode is available.
- Having two set points (SP) allows creating the hysteresis.
- The signal can be inverted.

¹² IOL-Interface-Spec_10002_V112_Jul13.pdf

- The default values of the set points are outside of the nominal pressure range so it is mandatory to set them for a working switch mode.
- The set points have to be scaled, same as the process values described in 5.1 *Process Data*, page 9, afterwards its unit is Pascal.

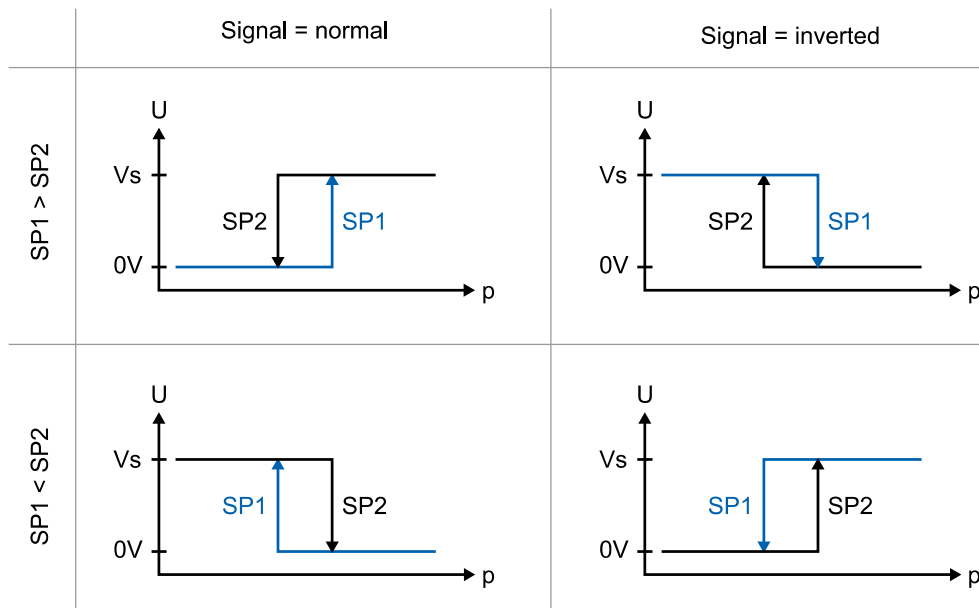

Fig 3 Effect of the parameters to the switching characteristic

Tab 15 Indexes 60/61, Pressure Switch Point

Index	Sub-ind.	Access	Min.	Max.	Default	Meaning
60	1	RW	X	X	X	Set point 1 [Pa], X: depends on the specified pressure range
60	2	RW	X	X	X	Set point 2 [Pa], X: depends on the specified pressure range
61	1	RW	0	1	0	SSC Inverter: 0 = off, 1 = on
61	2	RW	3	3	3	Switch mode: 3 = two point

6.11 MDC Selector (Pressure/Temperature)

D1 -ac

This parameter can be used to select the cyclic Process Value "Pressure" (see chapter 6.9 *Pressure*, page 15) or "Process Temperature" (see chapter 6.17 *Process Temperature*, page 18).

Tab 16 Index 83, MDC Selector

Index	Sub-ind.	Access	Min.	Max.	Default	Meaning
83	1	RW	1	2	1	MDC Selector 1: Pressure, 2: Process Temperature

6.12 Part Number

D1 -/ac

The Part Number, alternatively known as material number, is stored on the pressure sensor. With it a further sensor of the same configuration can be ordered as it is used as the related identification.

Tab 17 Index 86, part number

Index	Sub-ind.	Access	Min.	Max.	Default	Meaning
86	0	RO	-	-	8 Zeros	Part Number (alternatively known as material number)

6.13 Adjustment Of Pressure Process Value

D1 -/ac

This parameter can be used as the numerical correction of the pressure process value. The parameter has to be scaled, same as the process values described in chapter 5.1 *Process Data*, page 9, afterwards its unit is Pascal. This parameter affects only the zero point. It can be used in case of low pressure ranges to correct any mounting effects or as well to correct the sensor's mounting orientation (e.g. downwards or horizontal).

Tab 18 Index 105, Adjustment Of The Process Value

Index	Sub-ind.	Access	Min.	Max.	Default	Meaning
105	1	RW	X	X	0	Numerical correction of the pressure process value [Pa], X: depends on the pressure range

6.14 Device Temperature

D1 -/ac

The Current Device Temperature is measured at the barometric pressure measuring cell towards the electrical connection of the pressure sensor. It is a mixture between the ambient and sensor internal conditions. This Current Device Temperature might be used as indication for the general sensor temperature. In combination with the two other temperature CPU¹³ and process¹⁴ a kind of temperature gradient can be determined for further processing and analysis, e.g. for lifetime monitoring (predictive maintenance).

Tab 19 Index 208, Current Device Temperature

Index	Sub-ind.	Access	Min.	Max.	Default	Meaning
208	1	RO	-	-	-	Current Device Temperature [°C]

¹³ See chapter 6.15 *CPU Temperature*, page 14

¹⁴ See 6.17 *Process Temperature*, page 15

6.15 CPU Temperature

D1 -/ac

- This temperature is measured directly on the CPU around in half the length of the tubular housing.
- The temperature is given in degree Celsius (°C).
- This temperature is just an indication of the sensor itself and is influenced by the CPU's present operating grade.
- The temperature information might be used on long term to analyse the temperature load profile and therefor of assessing its lifetime.

Tab 20 Index 209, CPU Temperature

Index	Sub-ind.	Access	Min.	Max.	Default	Meaning
209	1	RO	-	-	-	Current CPU Temperature [°C]

6.16 Time Since Last Power-up

D1 -/ac

The sensor records the elapsed time since the last power-up. It will be automatically reset to zero in case of a restarting of the pressure sensor.

Tab 21 Index 211, Elapsed Time Since Last Power-up

Index	Sub-ind.	Access	Min.	Max.	Default	Meaning
211	1	RO	0	32 ² - 1	-	Time since power-up [s], max. 136 years

6.17 Process Temperature

D1 c/ac

- This temperature is measured directly on the PP20H-D1 process pressure cell.
- The temperature is given in degree Celsius (°C).
- This temperature is an indication and not highly accurate. Furthermore it suites for slow changing medium temperatures only.

Tab 22 Index 214, Process Temperature

Index	Sub-ind.	Access	Min.	Max.	Default	Meaning
214	1	RO	-	-	-	Current Process Temperature [°C]

6.18 Current Ambient Pressure

D1 -/ac

The sensor can deliver the information about the current ambient pressure which might be of interest e.g. for physical effects as the saturated steam curve (boiling point of water). The information about the barometric pressure is given in Pascal.

Tab 23 Index 215, Current Ambient Pressure

Index	Sub-ind.	Access	Min.	Max.	Default	Meaning
215	1	RO	-	-	-	Current Ambient Pressure [Pa]

6.19 Display Control Values

D1 -/ac

These parameters are used to control the IO-Link display (graphical user interface, GUI). Please refer to the IODD to see the different definitions (value and related explanations). The index describes how the information about physical measurement values are displayed.

Tab 24 Index 1024, Display Control Values

Index	Sub-ind.	Access	Min.	Max.	Default	Meaning
1024	1	RO	0	255	-	Information about the current selected cyclic Process Value "Pressure" or "Process Temperature" (Selected Process Value, Unit and Scale Exponent)
1024	2	RO	0	255	-	Information about the acyclic parameters related to the Process Value "Pressure" (Unit and Scale Exponent)
1024	3	RO	0	255	-	Information about the acyclic parameters related to the Process Value "Process Temperature" (Unit and Scale Exponent)

6.20 MDC Descriptor

D1 -/ac

With the MDC Descriptor the cyclic sent data are described. As two different physical process data can be selected (see chapter 6.11 *MDC Selector (Pressure/Temperature)*, page 16) for each following sub-indexes need to be considered.

Pressure

- Sub-index 1: Upper nominal pressure limit which is possible, everything above is out of range
- Sub-index 2: Lower nominal pressure limit which is possible, everything below is out of range
- Sub-index 3: Pressure comes with the unit Pascal (Pa)
- Sub-index 4: Scale exponent x (10^x)

Process Temperature

- Sub-index 1: Upper nominal temperature limit which is possible, everything above is out of range
- Sub-index 2: Lower nominal temperature limit which is possible, everything below is out of range
- Sub-index 3: Temperature comes with the unit degree Celsius (°C)
- Sub-index 4: Scale exponent x (10^x)

The limits have to be scaled same as the process values described in chapter 5.1 *Process Data*, page 9, afterwards its unit is Pascal/degree Celsius.

Tab 25 Index 16512, MDC Descriptor

Index	Sub-ind.	Access	Min.	Max.	Default	Meaning
16512	1	RO	X	X	-	Lower Limit of the selected Process Value X: depends on the Process Value range
16512	2	RO	X	X	-	Upper Limit of the selected Process Value X: depends on the Process Value range
16512	3	RO	-	-	-	Unit Code of the selected Process Value ¹⁵
16512	4	RO	-	-	-	Scale Exponent of the selected Process Value

¹⁵ Standardised by IO-Link consortium, see *IOL-Smart-Sensor-Profile-2ndEd_V10_Mar2017.pdf*, A.5.7

7 Appendix

7.1 Tables

Tab 1	Document History	3
Tab 2	IO-Link Process Data Input	9
Tab 3	Failures and alarms	10
Tab 4	Recommended Further Steps In Case Of Alarm Bit = 1	10
Tab 5	Index 2, System Command	12
Tab 6	Index 12, Device Access Locks	12
Tab 7	Available Device Access Locks possibilities	12
Tab 8	Index 13, DeviceProfileID: Smart Sensor Profile	13
Tab 9	Index 13, DeviceProfileID: Digital Measuring Sensor, SSP 3.4	13
Tab 10	Index 13, FunctionClassID: Binary Data Channel	13
Tab 11	Index 14, Process Data Input Description	14
Tab 12	Index 16 ... 23, Product Information	14
Tab 13	Index 24 ... 26, Tags	15
Tab 14	Index 36/37, Device Status	15
Tab 15	Indexes 60/61, Pressure Switch Point	16
Tab 16	Index 83, MDC Selector	16
Tab 17	Index 86, part number	17
Tab 18	Index 105, Adjustment Of The Process Value	17
Tab 19	Index 208, Current Device Temperature	17
Tab 20	Index 209, CPU Temperature	18
Tab 21	Index 211, Elapsed Time Since Last Power-up	18
Tab 22	Index 214, Process Temperature	18
Tab 23	Index 215, Current Ambient Pressure	19
Tab 24	Index 1024, Display Control Values	19
Tab 25	Index 16512, MDC Descriptor	20

7.2 Baumer Worldwide

Belgium

Baumer SA/NV
BE-2260 Westerlo
Phone +32 14 57462 0

Brasil

Baumer do Brasil Ltda
BR-04726-001 São Paulo-Capital
Phone +55 11 56410204

Canada

Baumer Inc.
CA-Burlington, ON L7M 4B9
Phone +1 (1)905 335-8444

China

Baumer (China) Co., Ltd.
CN-201612 Shanghai
Phone +86 (0)21 6768 7095

Denmark

Baumer A/S
DK-8210 Aarhus V.
Phone +45 (0)8931 7611

France

Baumer SAS
FR-74250 Fillinges
Phone +33 (0)450 392 466

Germany/Austria

Baumer GmbH
DE-61169 Friedberg
Phone +49 (0)6031 60 070

India

Baumer India Private Ltd.
IN-411038 Pune
Phone +91 (0)20 2528 6833

Italy

Baumer Italia S.r.l.
IT-20090 Assago, MI
Phone +39 (0)245 70 60 65

Poland

Baumer Sp.z.o.o.
PL-03-310 Warszawa
Phone +48 228321550

Republic of Korea

Baumer (Korea) Co., Ltd.
KR-411-766 Seoul
Phone +82-70-5055-0741 or
+82-31-995-6379

Singapore

Baumer (Singapore) Pte. Ltd.
SG-339412 Singapore
Phone +65 6396 4131

Spain

Baumer Automación Ibérica S.L
ES-08021 Barcelona
Phone +34 932547864

Sweden

Baumer A/S
SE-56122 Huskvarna
Phone +46 (0)36 13 94 30

Switzerland (Headquarter)

Baumer Electric AG
CH-8501 Frauenfeld
Phone +41 (0)52 728 1122

United Arab Emirates

Baumer Middle East FZE
AE-0 Dubai
Phone +971 48876755

United Kingdom

Baumer Ltd.
GB-Watchfield, Swindon, SN6 8TZ
Phone +44 (0)1793 783 839

USA

Baumer Ltd.
US-Southington, CT 06489
Phone +1 (1)860 621-2121

www.baumer.com/worldwide

Technical data has been fully checked, but accuracy of printed matter not guaranteed.