

# Inductive distance measuring sensors

**IR12.D06L-11135332**

**dimension drawing**

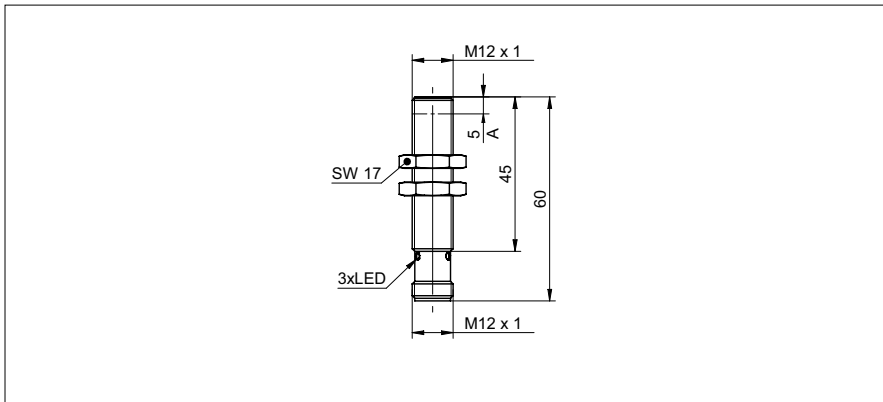

**general data**

mounting type	quasi-flush
special type	2 adjust. switching points linearized
measuring distance Sd	0 ... 6 mm
sensitivity	1,67 V/mm
resolution	< 0,003 mm (stat.) < 0,005 mm (dynam., S = 0 ... 4 mm) < 0,022 mm (dynam., S = 0 ... 6 mm)
repeat accuracy	< 0,01 mm
adjustment	external Teach-in
teach	1-point analog, window digital, factory reset
linearity error	± 25 µm (S = 0 ... 4 mm) ± 60 µm (S = 0 ... 6 mm)
temperature drift	± 2 % (Full Scale; S = 0 ... 4 mm) ± 5 % (Full Scale; S = 0 ... 6 mm)

**photo**



**electrical data**

response time (factory characteristic)	< 1 ms
voltage supply range +Vs	12 ... 36 VDC
current consumption max. (no load)	15 mA
output circuit	voltage output / PNP
output signal	0 ... 10 VDC
load resistance	> 4000 Ohm
output current	< 100 mA (PNP)
short circuit protection	yes
reverse polarity protection	yes

**connection diagram**

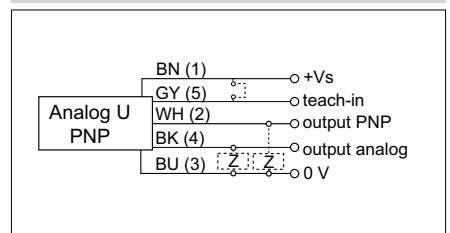

**mechanical data**

type	cylindrical threaded
housing material	brass nickel plated
dimension	12 mm
housing length	60 mm
connection types	connector M12
tightening torque max.	15 Nm (A: 10 Nm)

**ambient conditions**

operating temperature	-25 ... +75 °C (Vs = 12 ... 30 VDC) -25 ... +60 °C (Vs = 12 ... 36 VDC)
protection class	IP 67



- external Teach-in
- integrated analog- and switching output
- linear analog output