

Sine encoders

Insulated through hollow shaft $\varnothing 0.375...1$ inch

1024...2048 sinewave cycles per turn

HS35S - Sine



HS35S with insulated hollow shaft

Features

- Rugged design up to IP 67 protection
- Shock resistant up to 200 g's
- Insulating insert to prevent high shaft currents from damaging bearings
- Wide range voltage supply 4.75...30 VDC
- Precision ≤ 60 arc-seconds for perfect process control
- Patented LowHarmonics® technology
- Outstanding signal quality for superior speed control

Technical data - electrical ratings

Voltage supply	4.75...30 VDC
Reverse polarity protection	Yes
Consumption w/o load	≤ 90 mA
Sinewave cycles per turn	1024...5000
Accuracy	≤ 60 arc-seconds
Sensing method	Optical
Output frequency	≤ 180 kHz (-3 dB)
Output signals	A+, A-, B+, B-, Z+, Z-
Output stages	SinCos 1 Vpp
Interference immunity	DIN EN 61000-6-2
Emitted interference	DIN EN 61000-6-3
Approvals	UL approval / file no. E240061, ROHS compliant EU guideline 2011/65/EC, CE

Technical data - mechanical design

Size (flange)	$\varnothing 3.15''$ ($\varnothing 80$ mm)
Shaft type	$\varnothing 0.375...1''$ ($\varnothing 9.525...25.4$ mm) (through hollow shaft isolated)
Bore runout	0.0016" (0.04 mm) TIR max.
Admitted misalignment	0.004" (0.1016 mm) radial TIR (end of shaft) 0.01" (0.254 mm) axial
Protection DIN EN 60529	IP 54, IP 65, IP 67
Operating speed	≤ 5000 rpm (see temperature diagram)
Bearing	52100 SAE high carbon steel (ABEC 5)
Starting torque	≤ 3 in-oz (77 °F, IP 65) ≤ 0.02 Nm (+25 °C, IP 65)
Rotor moment of inertia	2.3 oz-in ² (420 gcm ²)
Service life	Bearing: typ. 13 billion rev. (89000 h/2500 rpm)
Materials	Housing: aluminium, powder-coated Shaft: stainless steel
Operating temperature	-40...+212 °F (-40...+100 °C), (fixed cable): see temperature diagram
Relative humidity	98 % non-condensing
Resistance	DIN EN 60068-2-6 Vibration 20 g, 60-2000 Hz DIN EN 60068-2-27 Shock 200 g, 6 ms
Connection	MIL-connector, 10-pin Cable (AWG26 wire)
Weight approx.	23 oz., 660 g

Sine encoders

Insulated through hollow shaft $\varnothing 0.375...1$ inch

1024...2048 sinewave cycles per turn

HS35S - Sine

Part number

HS35S

	W	ABZC		E			
--	---	------	--	---	--	--	--

Mounting kit

- T1 Tether arm T1, fixed, bolt 3/8"
- T3 Tether arm T3, adjustable, bolt 1/4"
- T4 Tether arm T4, adjustable, bolt 5/16"
- T5 Tether arm T5, adjustable, bolt 3/8"
- T6 Tether arm T6, adjustable, kit, bolts 1/4", 5/16", 3/8"

Protection

- 4 IP 54
- 5 IP 65
- 7 IP 67 (dust cap included)

Through hollow shaft

- 100 $\varnothing 1.000''$ ($\varnothing 25.4$ mm)
- 087 $\varnothing 0.875''$ ($\varnothing 22.23$ mm)
- 075 $\varnothing 0.750''$ ($\varnothing 19.05$ mm)
- 062 $\varnothing 0.625''$ ($\varnothing 15.88$ mm)
- 050 $\varnothing 0.500''$ ($\varnothing 12.7$ mm)
- 037 $\varnothing 0.375''$ ($\varnothing 9.525$ mm)
- M20 $\varnothing 20$ mm
- M18 $\varnothing 18$ mm
- M16 $\varnothing 16$ mm
- M15 $\varnothing 15$ mm
- M14 $\varnothing 14$ mm
- M12 $\varnothing 12$ mm
- M10 $\varnothing 10$ mm

Operating temperature

E -40...+212 °F (-40...+100 °C)

Connection

- M10 MIL-connector, 10-pin (at ABZC)
- C012 Cable gland with cable and wire end sleeves L=12" (305 mm)
- C018 Cable gland with cable and wire end sleeves L=18" (457 mm)
- C024 Cable gland with cable and wire end sleeves L=24" (610 mm) **

Output signals

ABZC A+, A-, B+, B-, Z+, Z- (sine)

Voltage supply / signals

W $V_{in} = 4.75...30$ VDC - SinCos 1 Vpp

Sinewave cycles - see table

Sinewave cycles

01024	02048	05000
-------	-------	-------

** Other cable lengths on request.

Sine encoders

Insulated through hollow shaft $\varnothing 0.375...1$ inch

1024...2048 sinewave cycles per turn

HS35S - Sine

Output signals

Clockwise rotation when looking at the mounting side.

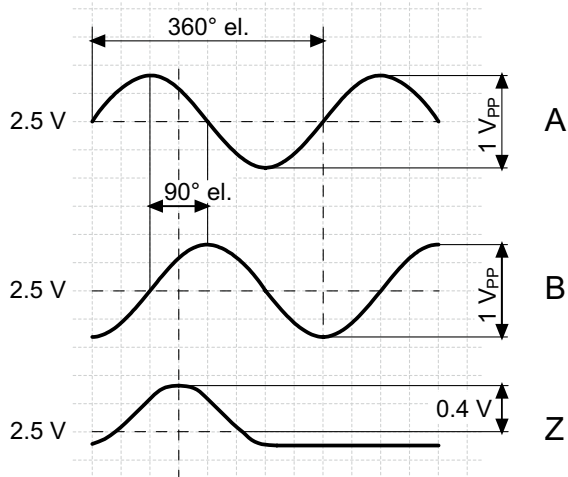

differential signals

Terminal assignment

MI10: MIL-connector, 10-pin

Connector	Assignment
Pin A	Track A +
Pin B	Track B +
Pin C	Track Z +
Pin D	+Vs
Pin E	-
Pin F	0 V
Pin G	Housing
Pin H	Track A -
Pin I	Track B -
Pin J	Track Z -

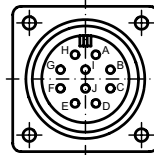

Cable gland (AWG26 wire)

Core colour	Assignment
green	Track A +
grey	Track B +
pink	Track Z +
red	+Vs
blue	0 V
transparent	Shield/Housing
brown	Track A -
black	Track B -
white	Track Z -

Sine encoders

Insulated through hollow shaft $\varnothing 0.375...1$ inch

1024...2048 sinewave cycles per turn

HS35S - Sine

Output signal level

Outputs	Sine
Output amplitude A + B	1 V _{PP} at Z ₀ = 120 Ω
Output amplitude N	approx. 0,4 V (useable part) at Z ₀ = 120 Ω

Temperature diagram

ambient temperature + self heating
 \leq max. operating temperature +212 °F (+100 °C)

self-heating per 1000 rpm:

IP 54: +9 °F (+5 °C)
 IP 65: +18 °F (+10 °C)
 IP 67: +27 °F (+15 °C)

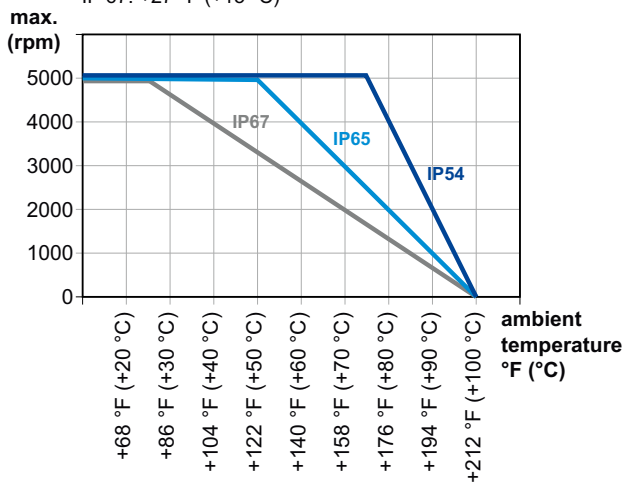

Accessories

Connectors and cables

11126235	NAC 29H 10-pin Mil Spec Mating Connector
11078307	CNAC 29H 10-pin Mil Spec Mating Connector + cable L = 10 feet (3.05 m)
11078427	CNAC 29H 10-pin Mil Spec Mating Connector + cable L = 20 feet (6.10 m)
11078428	CNAC 29H 10-pin Mil Spec Mating Connector + cable L = 30 feet (9.15 m)

Mounting accessories

11076339	Torque arm T1, fixed length, for bolt 3/8" with plastic clip and screws
11075692	Torque arm T3, adjustable length, for bolt 1/4" with plastic clip and screws
11075690	Torque arm T4, adjustable length, for bolt 5/16" with plastic clip and screws
11071506	Torque arm T5, adjustable length, for bolt 3/8" with plastic clip and screws
11167978	Torque arm T6, adjustable length, kit for bolts 1/4", 5/16" and 3/8" with plastic clip and screws
11084462	Reducer insert HS35 $\varnothing 0.375"$ ($\varnothing 9.525$ mm)
11078636	Reducer insert HS35 $\varnothing 0.50"$ ($\varnothing 12.7$ mm)
11080114	Reducer insert HS35 $\varnothing 0.625"$ ($\varnothing 15.875$ mm)
11078639	Reducer insert HS35 $\varnothing 0.75"$ ($\varnothing 19.05$ mm)
11078654	Reducer insert HS35 $\varnothing 0.87"$ ($\varnothing 22.225$ mm)
11087744	Reducer insert HS35 $\varnothing 10$ mm
11087745	Reducer insert HS35 $\varnothing 12$ mm
11087746	Reducer insert HS35 $\varnothing 14$ mm
11148651	Reducer insert HS35 $\varnothing 15$ mm
11087747	Reducer insert HS35 $\varnothing 16$ mm
11087748	Reducer insert HS35 $\varnothing 18$ mm
11087750	Reducer insert HS35 $\varnothing 20$ mm
11075459	Dust cap HS35
11080884	Protective cage HS35

Sine encoders

Insulated through hollow shaft $\varnothing 0.375...1$ inch

1024...2048 sinewave cycles per turn

HS35S - Sine

Dimensions

HS35S

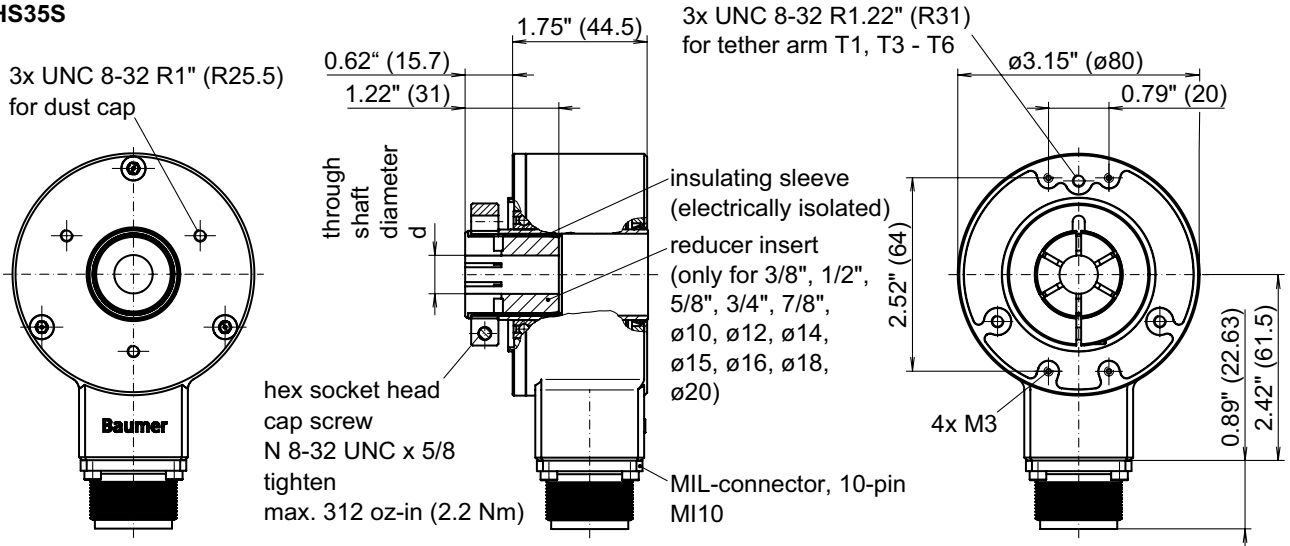

\varnothing nominal dimension		tolerance						
		hollow shaft encoder				recommended customer shaft		
inch (in")	metric (in mm)		inch (in 1/1000")	metric (in μ m)		inch (in 1/1000")	metric (in μ m)	
1.000"	25.400	G7	+1.10 +0.28	+28 +7	h6	0 -0.51	0 -13	
0.875"	22.225	G7	+1.10 +0.28	+28 +7	h6	0 -0.51	0 -13	
0.750"	19.050	G7	+1.10 +0.28	+28 +7	h6	0 -0.51	0 -13	
0.625"	15.875	G7	+0.94 +0.24	+24 +6	h6	0 -0.43	0 -11	
0.500"	12.700	G7	+0.94 +0.24	+24 +6	h6	0 -0.43	0 -11	
0.375"	9.525	G7	+0.79 +0.20	+20 +5	h6	0 -0.35	0 -9	
0.787"	20	H8	+1.30 0	+33 0	g6	-0.28 -0.79	-7 -20	
0.709"	18	H8	+1.06 0	+27 0	g6	-0.24 -0.67	-6 -17	
0.630"	16	H8	+1.06 0	+27 0	g6	-0.24 -0.67	-6 -17	
0.591"	15	H8	+1.06 0	+27 0	g6	-0.24 -0.67	-6 -17	
0.551"	14	H8	+1.06 0	+27 0	g6	-0.24 -0.67	-6 -17	
0.472"	12	H8	+1.06 0	+27 0	g6	-0.24 -0.67	-6 -17	
0.394"	10	H8	+1.06 0	+27 0	g6	-0.20 -0.55	-5 -14	

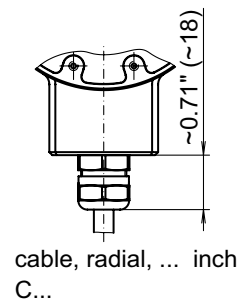
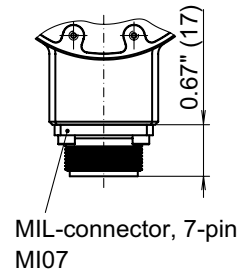

039- 6

Sine encoders

Insulated through hollow shaft $\varnothing 0.375...1$ inch
1024...2048 sinewave cycles per turn

HS35S - Sine

Dimensions

Tether arm T1

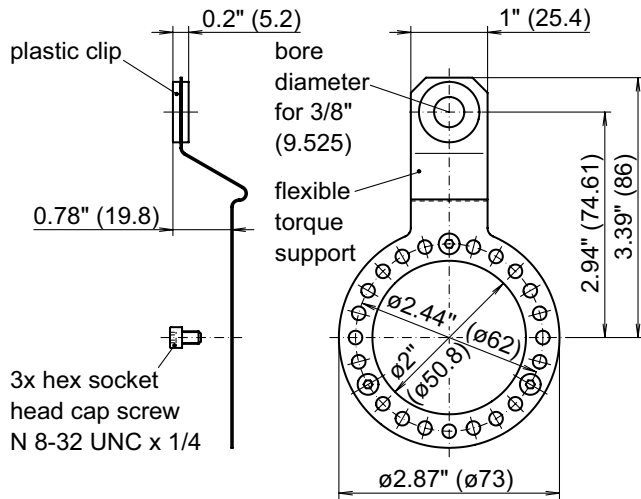

Tether arm T3

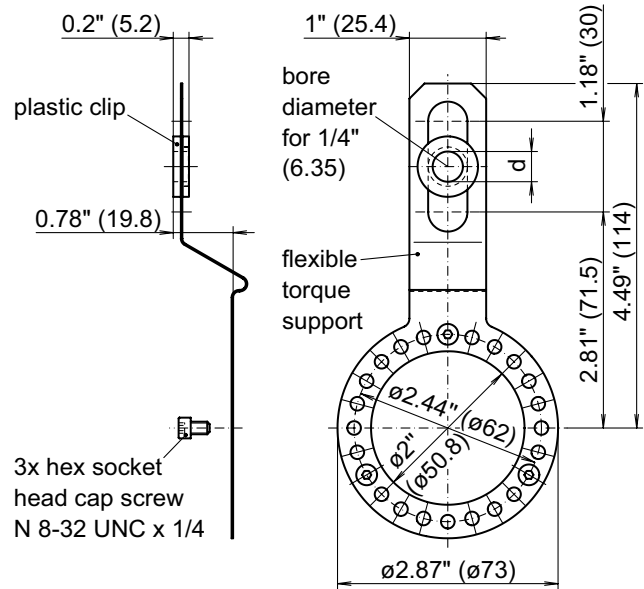

Tether arm T4

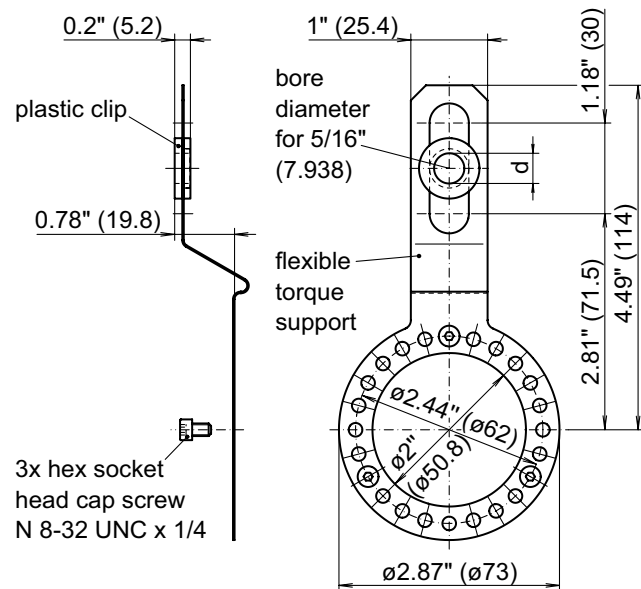

Tether arm T5

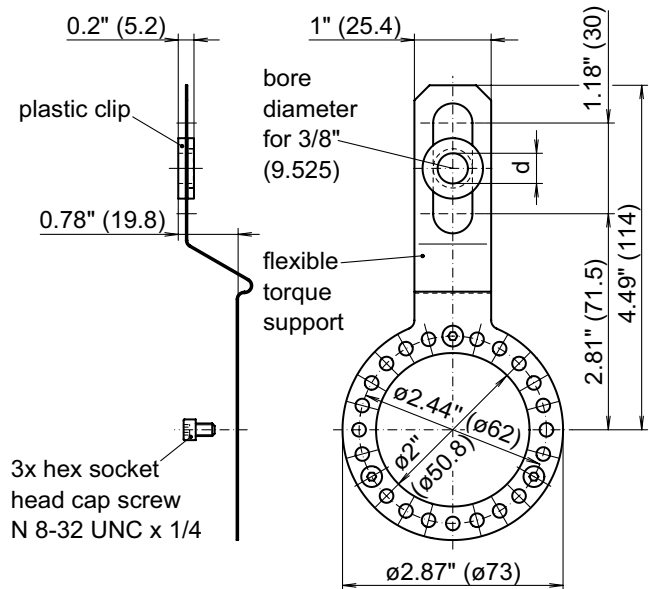

Sine encoders

Insulated through hollow shaft $\varnothing 0.375...1$ inch

1024...2048 sinewave cycles per turn

HS35S - Sine

Dimensions

Tether arm T6

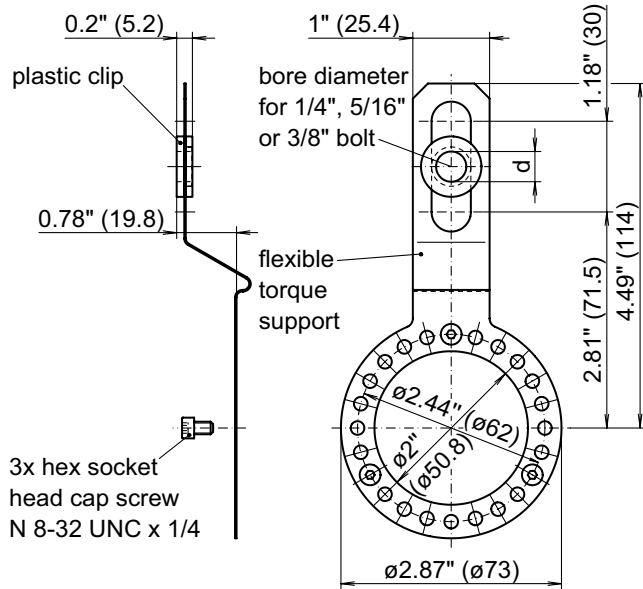

Reducer inserts

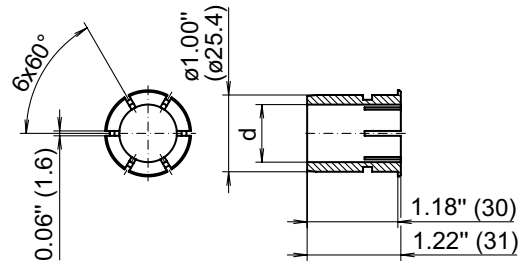

\varnothing nominal dimension		tolerance		
inch (in ")	metric (in mm)		inch (in 1/1000")	metric (in μ m)
0.875"	22.225	G7	+1.10 +0.28	+28 +7
0.750"	19.050	G7	+1.10 +0.28	+28 +7
0.625"	15.875	G7	+0.94 +0.24	+24 +6
0.500"	12.700	G7	+0.94 +0.24	+24 +6
0.375"	9.525	G7	+0.79 +0.20	+20 +5
0.787"	20	H8	+1.30 0	+33 0
0.709"	18	H8	+1.06 0	+27 0
0.630"	16	H8	+1.06 0	+27 0
0.551"	15	H8	+1.06 0	+27 0
0.551"	14	H8	+1.06 0	+27 0
0.472"	12	H8	+1.06 0	+27 0
0.394"	10	H8	+1.06 0	+27 0

Dust cap HS35

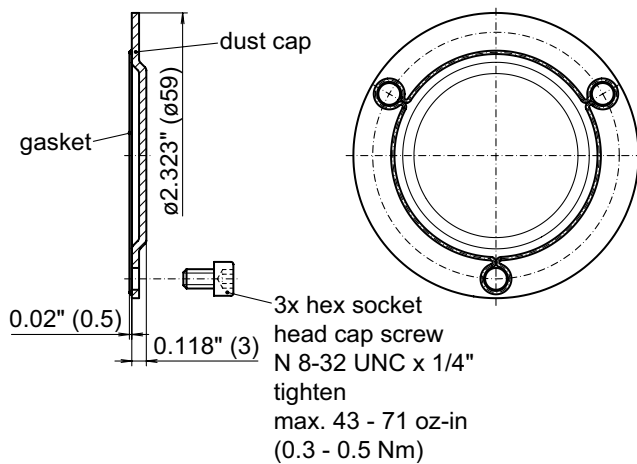

Protective cage HS35

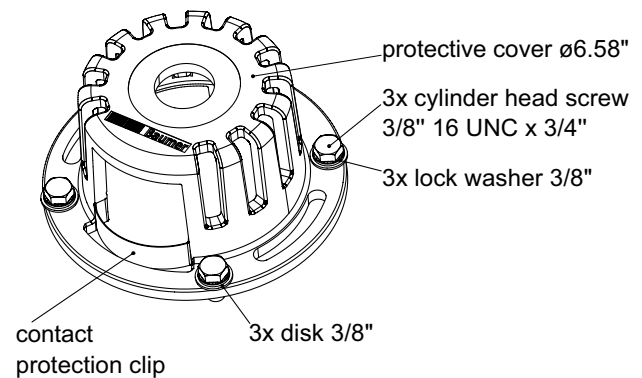

Sine encoders

Insulated through hollow shaft $\varnothing 0.375 \dots 1$ inch
1024...2048 sinewave cycles per turn

HS35S - Sine

Dimensions

Example fitting tether arm

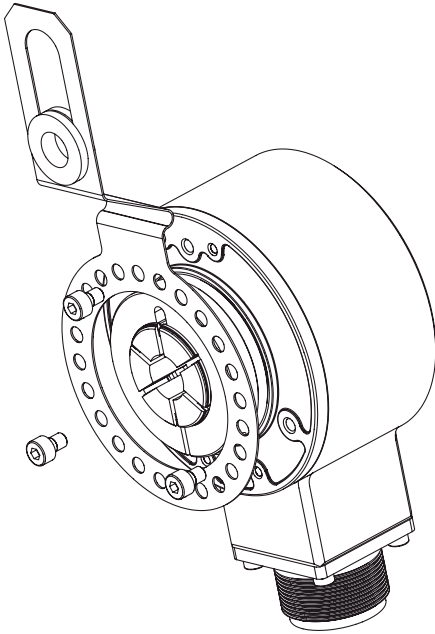

Example fitting dust cap

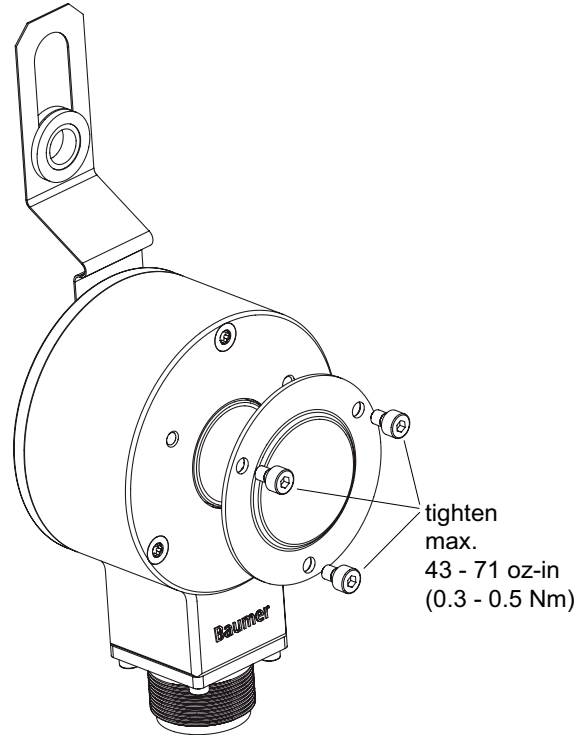

Example fitting protective cover

