

# Combination

Encoder with integrated electronic speed switch

Blind hollow shaft or cone shaft

300...5000 pulses per revolution

HOG 11 + ESL 93

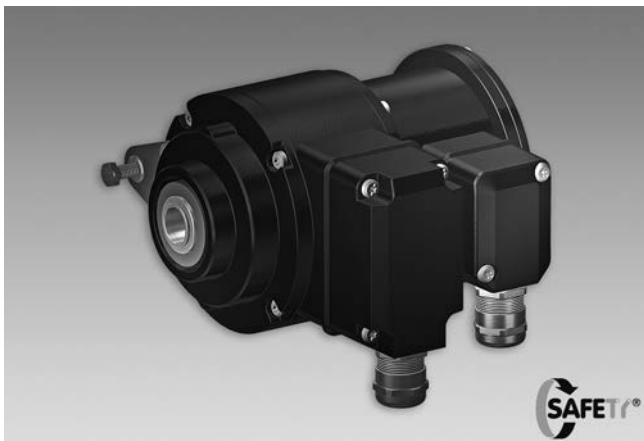

HOG 11 + ESL 93

## Features

- Offshore and salt water firm, high protection IP 67
- TTL output driver for cable length up to 550 m
- Electronic speed monitoring
- Circuit breaker with up to three selectable threshold speeds
- Hybrid bearing for extended service life
- Terminal boxes, turn by 180°

## Optional

- Function control with EMS (Enhanced Monitoring System)
- Redundant sensing with two terminal boxes

## Technical data - electrical ratings

Shaft insulation	Suitable up to 2.8 kV
Interference immunity	EN 61000-6-2
Emitted interference	EN 61000-6-3

## Technical data - electrical ratings (encoder)

Voltage supply	9...30 VDC; 5 VDC $\pm$ 5 %
Consumption w/o load	$\leq$ 100 mA
Pulses per revolution	300...5000
Phase shift	90° $\pm$ 20°
Duty cycle	40...60 %
Reference signal	Zero pulse, width 90°
Output frequency	$\leq$ 120 kHz $\leq$ 300 kHz (on request)
Output signals	K1, K2, K0 + inverted Error output (option EMS)
Output stages	HTL, TTL/RS422

## Technical data - electrical ratings (speed switches)

Voltage supply	12 VDC $\pm$ 10 %
Consumption w/o load	$\leq$ 5 mA
Switching accuracy	$\pm$ 4 % ( $\leq$ 1500 rpm) $\pm$ 2 % ( $>$ 1500 rpm)
Switching hysteresis	$\approx$ 30 % of switching speed
Switching outputs	3 outputs, speed control
Current each output	40 mA
Switching delay time	$\leq$ 40 ms

## Technical data - mechanical design

Size (flange)	$\varnothing$ 105 mm
Shaft type	$\varnothing$ 16...20 mm (blind hollow shaft) $\varnothing$ 17 mm (cone shaft 1:10)
Admitted shaft load	$\leq$ 450 N axial, $\leq$ 600 N radial
Protection DIN EN 60529	IP 67
Operating speed	$\leq$ 5000 rpm
Range of switching speed (ns)	3x 200...5000 rpm
Operating torque typ.	6 Ncm
Rotor moment of inertia	680 gcm <sup>2</sup>
Materials	Housing: aluminium die-cast Shaft: stainless steel
Operating temperature	-20...+85 °C
Resistance	IEC 60068-2-6 Vibration 5 g, 10-2000 Hz IEC 60068-2-27 Shock 50 g, 6 ms
Corrosion protection	IEC 60068-2-52 Salt mist for ambient conditions CX (C5-M) according to ISO 12944-2
Shaft insulation	2.8 kV
Transmission length	$\leq$ 350 m at 100 kHz (HTL-P) $\leq$ 550 m at 100 kHz (TTL)
Connection	2x terminal box 3x terminal box (with option M)
Weight approx.	2.3 kg, 2.5 kg (with option M)
Approval	CE

# Combination

Encoder with integrated electronic speed switch

Blind hollow shaft or cone shaft

300...5000 pulses per revolution

HOG 11 + ESL 93

## Part number

HOG11 

		DN				SR		+ ESL93		...		...		...
--	--	----	--	--	--	----	--	---------	--	-----	--	-----	--	-----

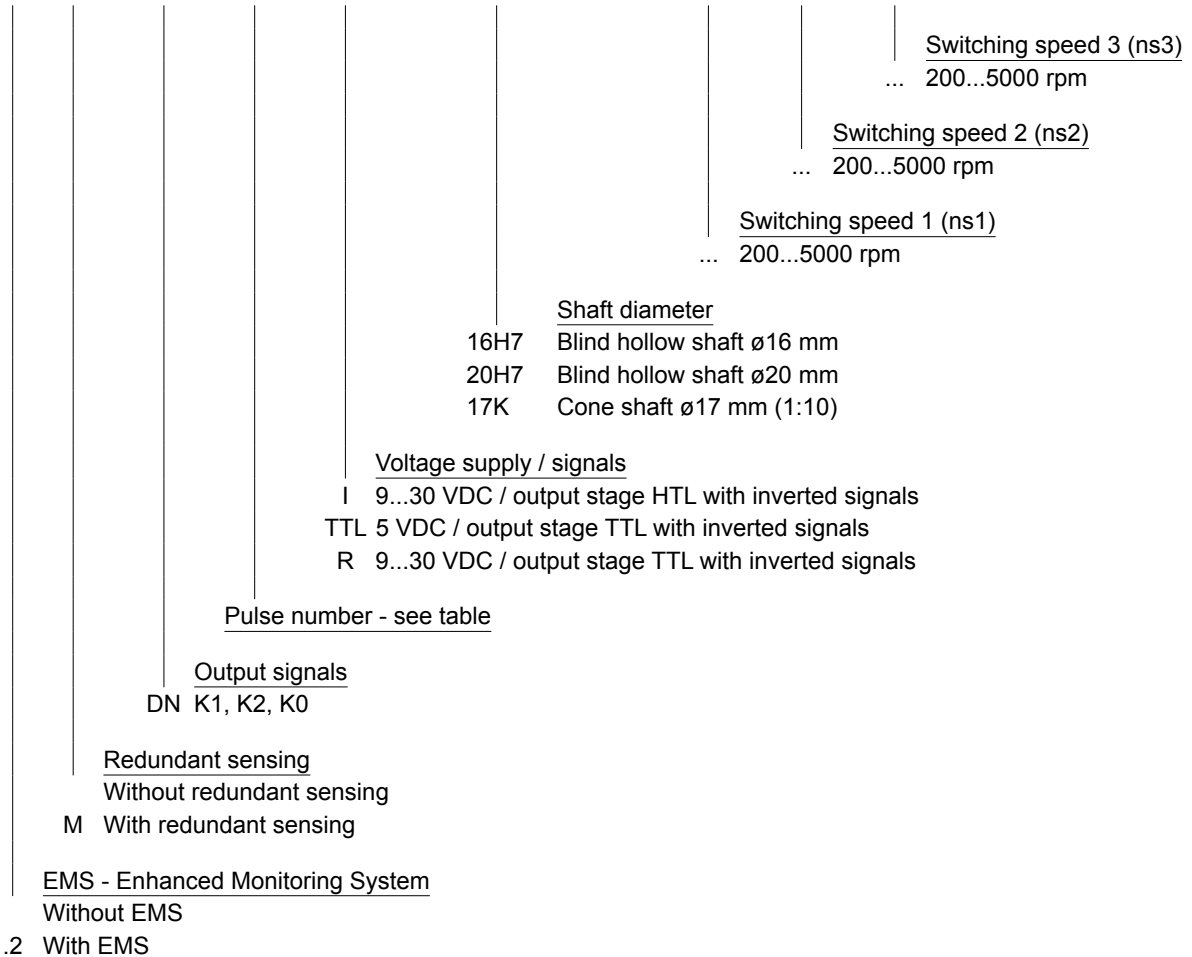

## Pulse number

300	1000	2048	4096
500	1024	2500	5000
512	1200	3072	

Other pulse numbers on request.  
 Please indicate the exact switching rotation speeds (factory setting).

---

## Accessories

### Connectors and cables

HEK 8	Sensor cable for encoders
-------	---------------------------

### Mounting accessories

11077197	Mounting kit for torque arm size M6 and earthing strap
----------	--

11077087	Mounting and dismantling set
----------	------------------------------

11043628	Torque arm M6, length 67-70 mm
----------	--------------------------------

11004078	Torque arm M6, length 120-130 mm (shortenable $\geq 71$ mm)
----------	---

11002915	Torque arm M6, length 425-460 mm (shortenable $\geq 131$ mm)
----------	--

11054917	Torque arm M6 insulated, length 67-70 mm
----------	--

11072795	Torque arm M6 insulated, length 120-130 mm (shortenable $\geq 71$ mm)
----------	---

11082677	Torque arm M6 insulated, length 425-460 mm (shortenable $\geq 131$ mm)
----------	--

### Diagnostic accessories

11075858	Analyzer for encoders HENQ 1100
----------	---------------------------------

11075880	Analyzer for encoders HENQ 1100 with a power pack
----------	---

### Relay module

11054943	Relay modul ES 93 R
----------	---------------------

## Encoder with integrated electronic speed switch

Blind hollow shaft or cone shaft

300...5000 pulses per revolution

### HOG 11 + ESL 93

#### Output signals

At positive rotating direction

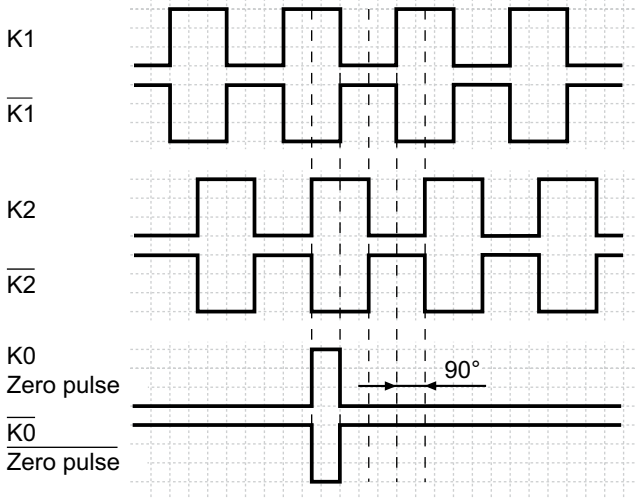

#### Option EMS: LED status / Error output

Flash light red*	Error of signal sequence, zero pulse or pulses (Error output = HIGH-LOW alternation)
Red	Overload output driver (Error output = LOW)
Flash light green	Device o.k., rotating (Error output = HIGH)
Green	Device o.k., stopped (Error output = HIGH)
No light	No voltage supply connection or wrong connection (Error output = LOW)

\* Only at rotating device

#### Terminal assignment

##### View A

Connecting terminal terminal box HOG 11

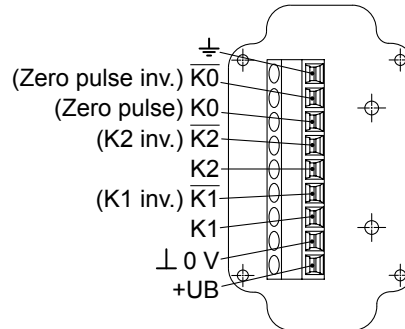

##### Option EMS: View A

Connecting terminal terminal box HOG 11.2

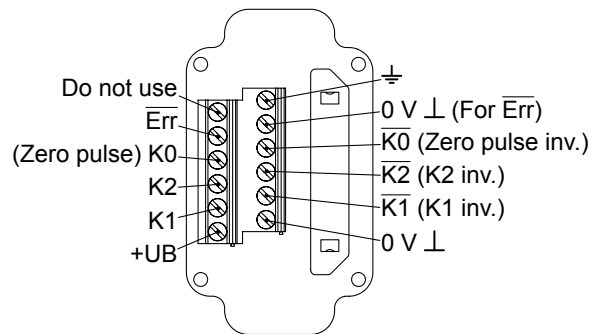

##### View B

Connecting terminal electronic speed switch ESL 93

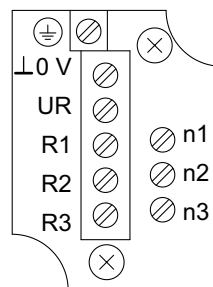

3 transistor outputs  
For connecting to a relay modul,  
for example ES 93 R (accessory)

# Combination

Encoder with integrated electronic speed switch  
Blind hollow shaft or cone shaft  
300...5000 pulses per revolution

HOG 11 + ESL 93

## Block circuit diagram

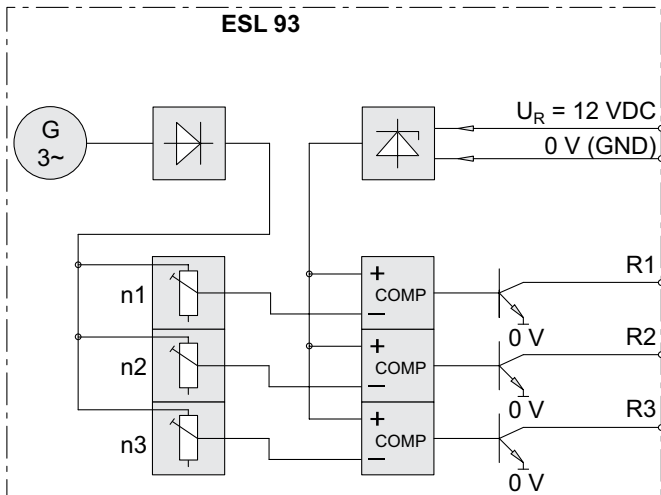

## Recommended output circuit

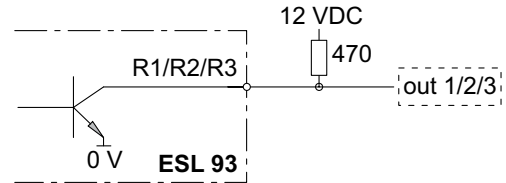

## Switching characteristics

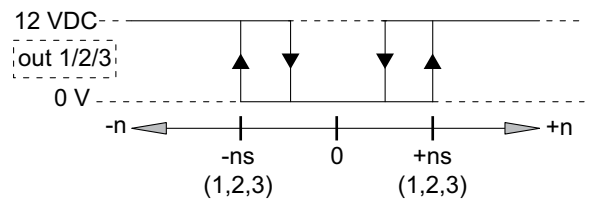

$n$  = speed  
 $n_s$  = adjusted switching speed

## Encoder with integrated electronic speed switch

### Blind hollow shaft or cone shaft

300...5000 pulses per revolution

## HOG 11 + ESL 93

### Dimensions

#### Blind hollow shaft

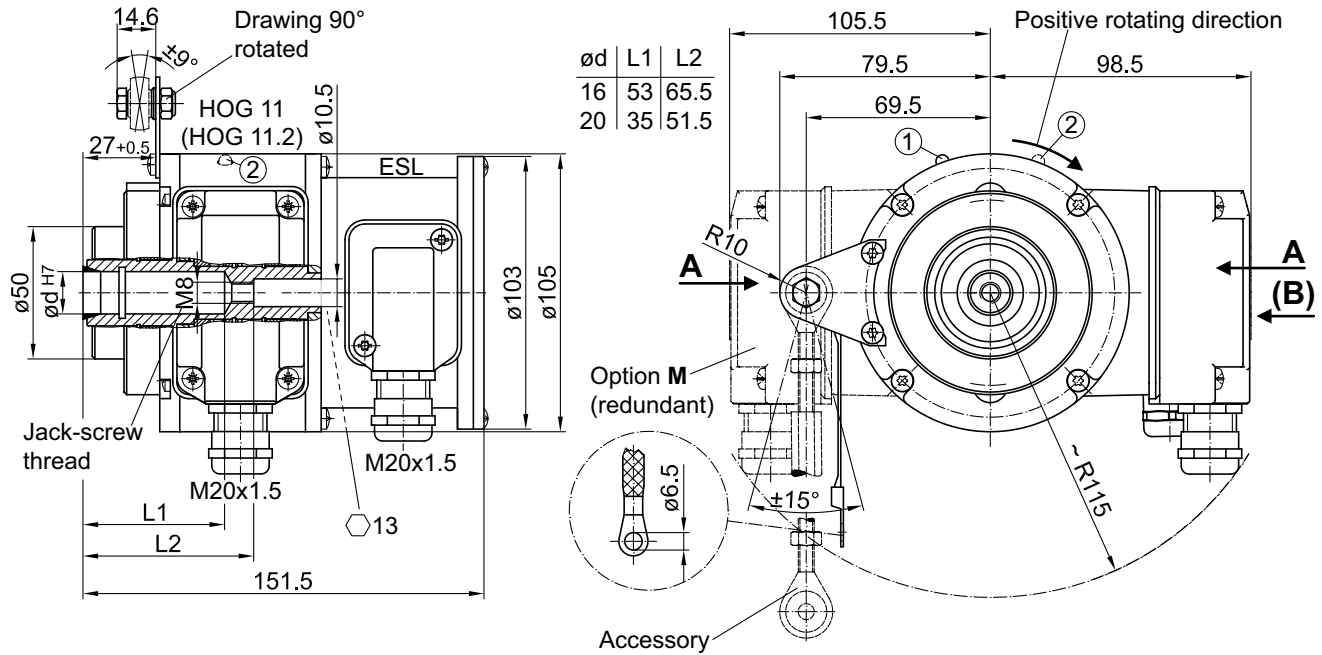

- ① Status LED (option EMS)
- ② Status LED (option **M** (redundant) and EMS)

#### Cone shaft

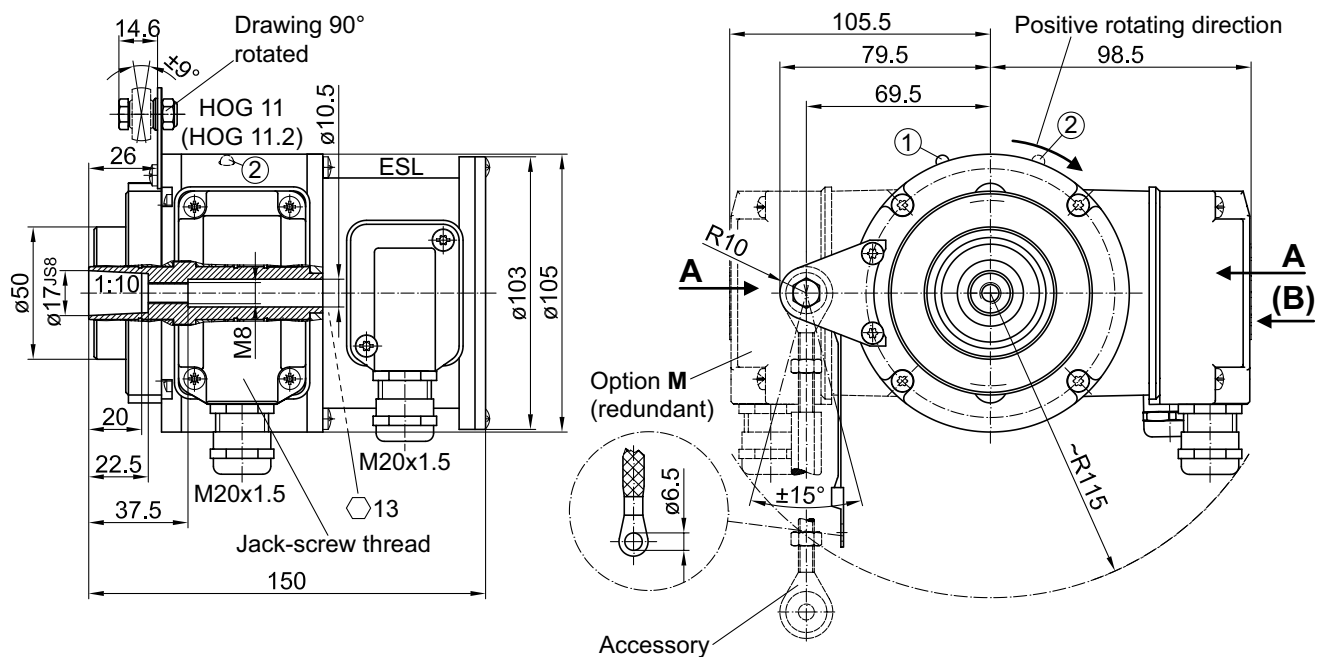

- ① Status LED (option EMS)
- ② Status LED (option **M** (redundant) and EMS)