

Incremental encoders

Blind hollow shaft $\varnothing 10$ to $\varnothing 14$ mm

50...1024 pulses per revolution

ITD 20 A 4 Y36



ITD 20 A 4 Y36 with blind hollow shaft

Features

- Encoder with blind hollow shaft $\varnothing 10...14$ mm
- Max. 1024 pulses per revolution
- Optical sensing method
- Mounting by torque support
- TTL or HTL output signals
- Cable output radial

Optional

- Cable with connector

Technical data - electrical ratings

Voltage supply	5 VDC $\pm 5\%$ 8...30 VDC
Reverse polarity protection	Yes
Consumption w/o load	≤ 100 mA
Pulses per revolution	50...1024
Reference signal	Zero pulse, width 90°
Sensing method	Optical
Output frequency	≤ 120 kHz
Output signals	A, B, N + inverted
Output stages	TTL linedriver (short-circuit proof) HTL push-pull (short-circuit proof)
Interference immunity	DIN EN 61000-6-2
Emitted interference	DIN EN 61000-6-3

Technical data - mechanical design

Size (flange)	$\varnothing 58$ mm
Shaft type	$\varnothing 10$ mm (blind hollow shaft) $\varnothing 12$ mm (blind hollow shaft) $\varnothing 14$ mm (blind hollow shaft)
Mounting kit	006
Protection DIN EN 60529	IP 65
Operating speed	≤ 8000 rpm
Starting torque	≤ 0.01 Nm ($+20^\circ\text{C}$)
Materials	Housing: aluminium, black, powder-coated Shaft: stainless steel
Operating temperature	$-20...+70^\circ\text{C}$
Relative humidity	90 % non-condensing
Resistance	DIN EN 60068-2-6 Vibration 10 g, 55-2000 Hz DIN EN 60068-2-27 Shock 100 g, 11 ms
Connection	Cable 1 m
Weight approx.	280 g

Incremental encoders

Blind hollow shaft $\varnothing 10$ to $\varnothing 14$ mm
50...1024 pulses per revolution

ITD 20 A 4 Y36

Part number

ITD 20 A 4 Y36 **KR1** **S** **IP65** **006**

Mounting kit
006 Mounting kit 006

Protection
IP65 IP 65

Blind hollow shaft
10 $\varnothing 10$ mm
12 $\varnothing 12$ mm
14 $\varnothing 14$ mm

Operating temperature
S -20...+70 °C

Connection
KR1 Cable 1 m, radial

Output signals
BI A, A inv, B, B inv
NI A, A inv, B, B inv, 0, 0 inv

Voltage supply / signals
T 5 VDC / TTL level, linedriver
H 8...30 VDC / HTL level, push-pull
R 8...30 VDC / TTL level, linedriver

Pulse number - see table

Pulse number

50	90	200	360	600
60	100	250	400	1000
64	120	254	500	1024
88	128	256	512	

Incremental encoders

Blind hollow shaft $\varnothing 10$ to $\varnothing 14$ mm
50...1024 pulses per revolution

ITD 20 A 4 Y36

Output signals

Clockwise rotation when looking at the mounting side.

BI-Output signals

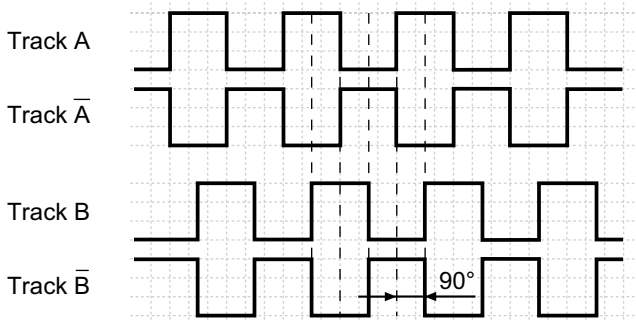

NI-Output signals

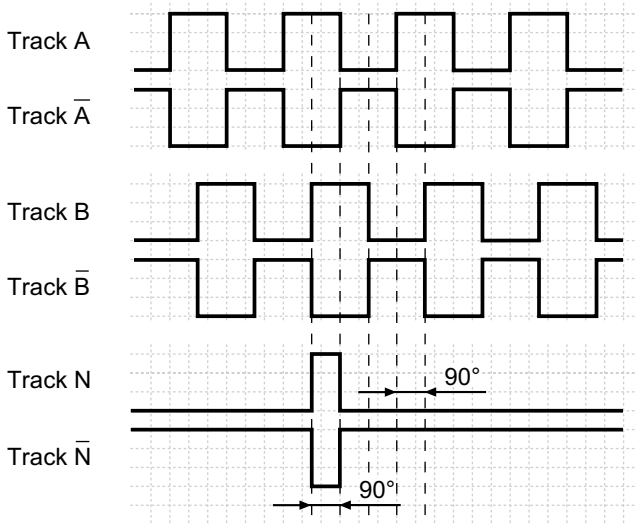

Terminal assignment

Core colour	Assignment
brown	Track A
green	Track A inv.
grey	Track B
pink	Track B inv.
red	Track N
black	Track N inv.
brown 0,5 mm ²	UB
white 0,5 mm ²	GND
blue	UB-Sense
white	GND-Sense
transparent	Shield/Housing

Trigger level

Outputs	Linedriver
Output level High	≥ 2.4 V
Output level Low	≤ 0.5 V
Load	≤ 70 mA

Outputs	Push-pull short-circuit proof
Output level High	$\geq UB - 3$ V
Output level Low	≤ 1.5 V
Load	≤ 70 mA

Incremental encoders

Blind hollow shaft $\varnothing 10$ to $\varnothing 14$ mm
50...1024 pulses per revolution

ITD 20 A 4 Y36

Dimensions

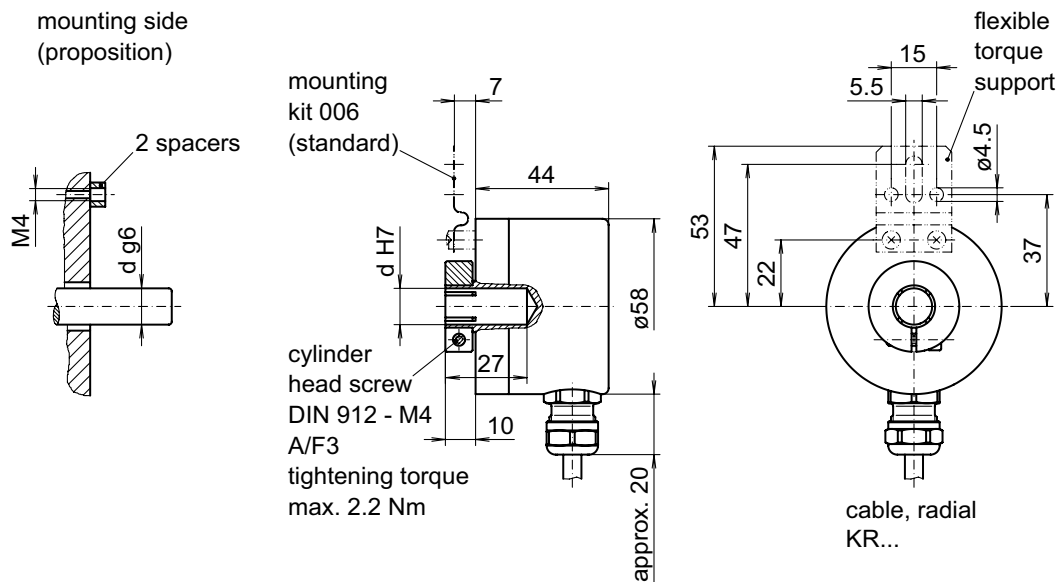

029- 1 Y36