

## ITD69H00 - Sine signal

Through hollow shaft  $\varnothing 40$  to  $\varnothing 65$  mm

128 sinewave cycles per revolution

### Overview

- Bearingless magnetic encoder
- 128 sinewave cycles per revolution
- Output circuit: Sine 1 Vpp
- Fast, easy and space saving installation
- Maintenance-free
- High accuracy - error max.  $\pm 0.2^\circ$
- Rotation speed max. 10000 rpm
- High resistance to dirt and vibrations

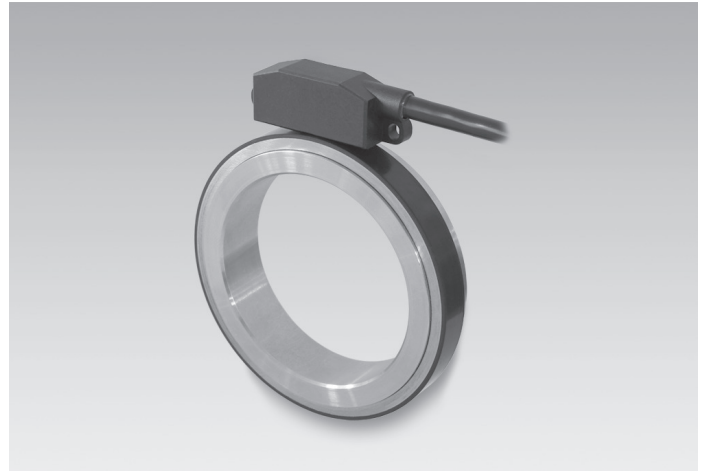

### Technical data

#### Technical data - electrical ratings

Voltage supply	5 VDC $\pm 10$ %
Reverse polarity protection	Yes
Short-circuit proof	Yes
Consumption w/o load	$\leq 50$ mA
Sinewave cycles per revolution	128
Output signals	A+, A-, B+, B- A+, A-, B+, B-, N+, N-
Output stages	SinCos 1 Vpp
Output frequency	$\leq 180$ kHz (-3 dB)
System accuracy	$\pm 0.2^\circ$
Interference immunity	DIN EN 61000-6-2
Emitted interference	DIN EN 61000-6-3

#### Technical data - mechanical design

Shaft type	$\varnothing 40 \dots 65$ mm (through hollow shaft)
Dimensions W x H x L	12 x 16 x 48 mm
Protection DIN EN 60529	IP 67 (relating to sealed electronics)
Operating speed	$\leq 10000$ rpm
Working distance	0,2 ... 0,5 mm (radial), optimal 0,3 mm
Axial offset	$\pm 0,5$ mm
Material	Housing: plastic Shaft: stainless steel
Operating temperature	$-40 \dots +100$ °C (fixed cable)
Resistance	DIN EN 60068-2-6 Vibration 10 g, 55-2000 Hz DIN EN 60068-2-27 Shock 100 g, 11 ms
Weight approx.	390 g
Connection	Cable 1 m
Admitted cable length	15 m

### Optional

- Cable with connector
- Redundant sensing

# ITD69H00 - Sine signal

Through hollow shaft  $\varnothing 40$  to  $\varnothing 65$  mm

128 sinewave cycles per revolution

## Terminal assignment

### With BI-signals, cable [4x2x0,08 mm<sup>2</sup>]

Core colour	Assignment
green	A +
yellow	A -
grey	B +
pink	B -
red	UB
blue	GND
transparent	Shield/Housing

### With NI-signals, cable [4x2x0,08 mm<sup>2</sup>]

Core colour	Assignment
green	A +
yellow	A -
grey	B +
pink	B -
brown	N +
white	N -
red	UB
blue	GND
transparent	Shield/Housing

## Output signals

Clockwise rotation when looking at the mounting side.

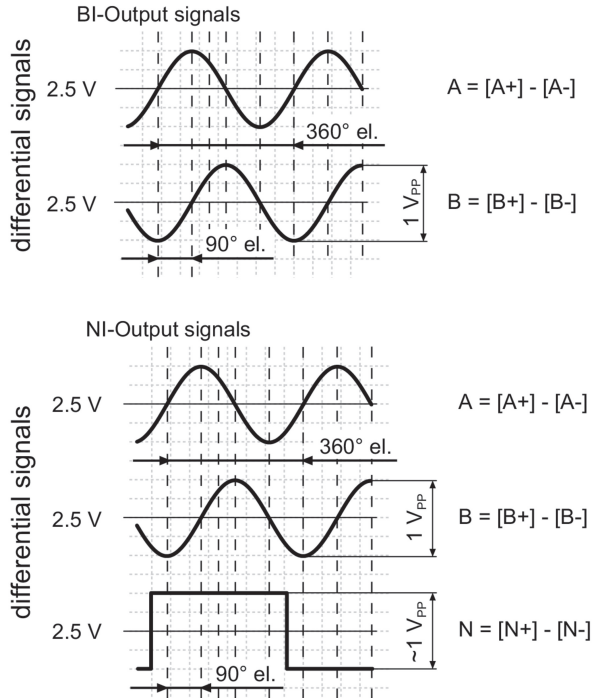

## Output signal level

Outputs	Sine
Output amplitude A + B	1 V <sub>PP</sub> at Z <sub>0</sub> = 120 Ω
Output amplitude N	approx. 2,5 V at Z <sub>0</sub> = 120 Ω

# ITD69H00 - Sine signal

Through hollow shaft  $\varnothing 40$  to  $\varnothing 65$  mm

128 sinewave cycles per revolution

## Dimensions

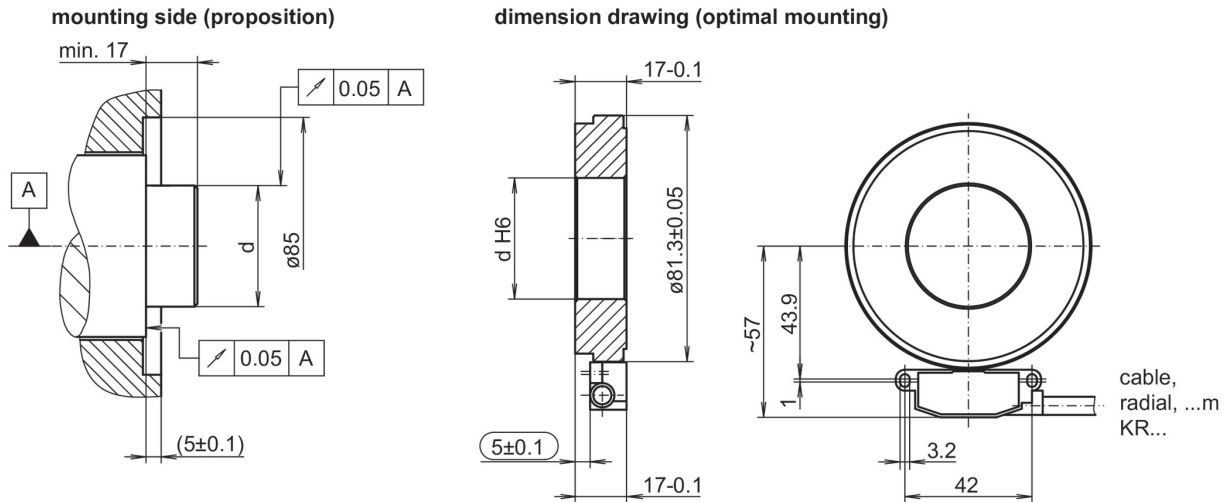

Mounting type	Shaft tolerance	Requirement
Shrink fitting	d p5	Maximum heating of the pole wheel $T_{(max)}=100$ °C
Adhesive mounting	d g6	Please observe the manufacturer's instructions for the adhesive mounting with respect to adhesives and adhesive air gap. Recommendation: Adhesive Loctite 3504

### Installation note:

The system, consisting of sensor and rotor, form a matched pair. They may not be exchanged individually. The sensor should be mounted on an electrically conductive surface on potting side.

## Mounting tolerances, operating tolerances

Permitted change of position sensor to rotor during mounting and operation:

### Axial offset:

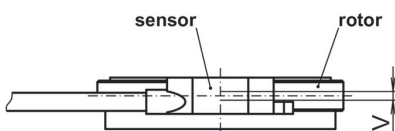

$V = \pm 0.5$  mm, optimal 0.1 mm

### Working distance:

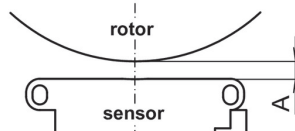

$A = 0.2 \dots 0.5$  mm,  
optimal 0.3 mm

Use the distance band as a mounting tool for optimal gap (0.3 mm) between sensor and rotor.

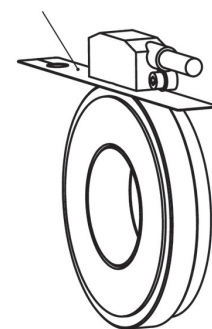

## Mounting position

Mounting position (1-1) sensor to rotor should not be altered!

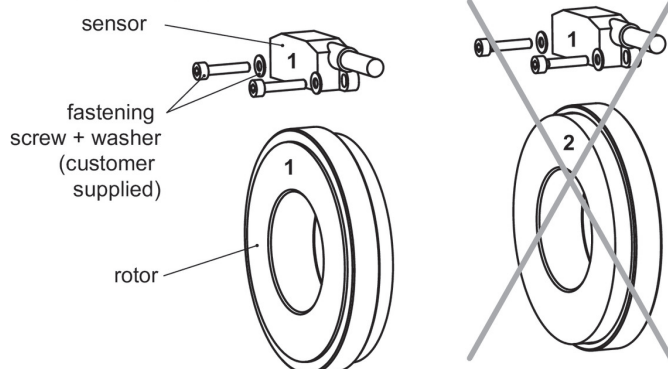

# ITD69H00 - Sine signal

 Through hollow shaft  $\varnothing 40$  to  $\varnothing 65$  mm

128 sinewave cycles per revolution

**Ordering reference**

	<b>ITD69H00</b>	<b>128</b>	<b>M</b>	<b>####</b>	<b>KR1</b>	<b>E</b>	<b>#####</b>	<b>67</b>
<b>Product</b>	ITD69H00							
<b>Sinewave cycles</b>		128						
<b>Voltage supply</b>								
UB= 5 VDC $\pm 10\%$ / sine 1 Vpp			M					
<b>Output signal sine</b>								
A+, A-, B+, B- (sine)					BI			
A+, A-, B+, B-, N+, N- (sine)					NI			
<b>Connection</b>								
Cable radial, 1.00 m					KR1			
<b>Operating temperature</b>								
-40...+100 °C (fixiertes Kabel)						E		
<b>Magnetic wheel H00</b>								
$\varnothing 40$ mm, for adhesive or heat-shrink mounting								40
$\varnothing 45$ mm, for adhesive or heat-shrink mounting								45
$\varnothing 50$ mm, for adhesive or heat-shrink mounting								50
$\varnothing 55$ mm, for adhesive or heat-shrink mounting								55
$\varnothing 60$ mm, for adhesive or heat-shrink mounting								60
$\varnothing 65$ mm, for adhesive or heat-shrink mounting								65
<b>Protection class</b>								
IP67 (relating to sealed electronics)								67

(1) Featured pulse numbers available as BI output signals.