

Incremental encoders

Solid shaft $\varnothing 6$ mm with synchro flange
100...512 pulses per revolution

OG 6



OG 6

Features

- Robust aluminium housing
- Encoder with solid shaft $\varnothing 6$ mm
- Optical sensing method
- Synchro flange
- Output stage HTL or TTL
- Output stage TTL with regulator UB 9...24 VDC

Technical data - electrical ratings

Voltage supply	9...26 VDC 5 VDC ± 5 % 9...24 VDC
Consumption w/o load	≤ 100 mA
Pulses per revolution	100...512
Phase shift	$90^\circ \pm 20^\circ$
Duty cycle	40...60 %
Reference signal	Zero pulse, width 90°
Sensing method	Optical
Output frequency	≤ 120 kHz
Output signals	K1, K2, K0 + inverted
Output stages	HTL TTL/RS422
Interference immunity	EN 61000-6-2
Emitted interference	EN 61000-6-3
Approvals	CE, UL approval / E256710

Technical data - mechanical design

Size (flange)	$\varnothing 58$ mm
Shaft type	$\varnothing 6$ mm solid shaft
Admitted shaft load	≤ 50 N axial ≤ 60 N radial
Flange	Synchro flange
Protection DIN EN 60529	IP 54
Operating speed	≤ 12000 rpm (mechanical)
Operating torque typ.	1 Ncm
Rotor moment of inertia	18 gcm ²
Materials	Housing: aluminium Shaft: stainless steel
Operating temperature	$-20 \dots +70$ °C
Resistance	IEC 60068-2-6 Vibration 10 g, 10-2000 Hz IEC 60068-2-27 Shock 100 g, 6 ms
Connection	Connecting terminal
Weight approx.	300 g

Subject to modification in technic and design. Errors and omissions excepted.

Incremental encoders

Solid shaft $\varnothing 6$ mm with synchro flange
100...512 pulses per revolution

OG 6

Part number

OG6 DN

--	--	--	--

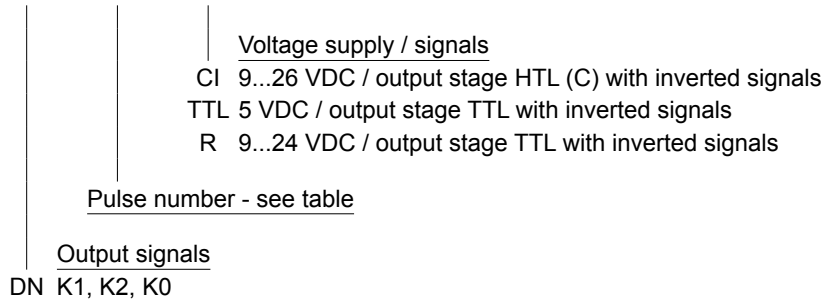

Pulse number

100	200	360	500	512
-----	-----	-----	-----	-----

Other pulse numbers on request.

Accessories

Eccentric disks
(clamping claws)

Connectors and cables

HEK 8 Sensor cable for encoders

Mounting accessories

K 35 Spring washer coupling
for solid shaft $\varnothing 6...12$ mm

Diagnostic accessories

11075858 Analyzer for encoders HENQ 1100

Incremental encoders

Solid shaft $\varnothing 6$ mm with synchro flange
100...512 pulses per revolution

OG 6

Output signals

At positive rotating direction

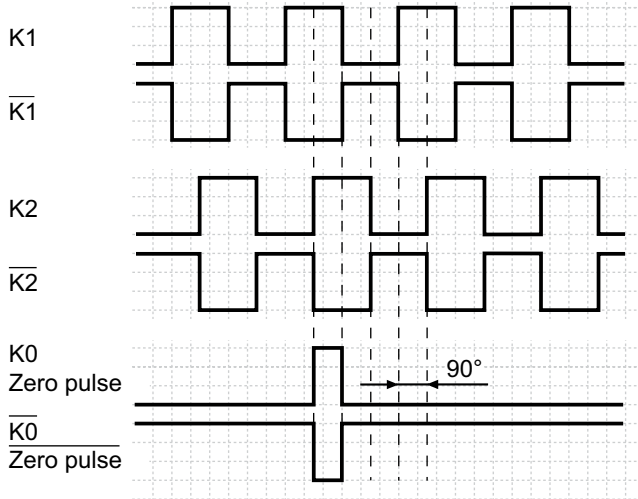

Terminal assignment

View A - Connecting terminal

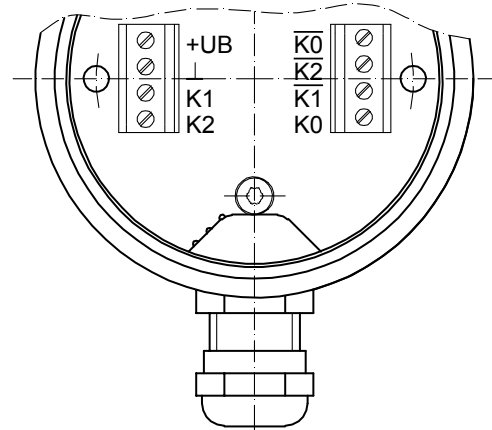

Terminal significance

+UB	Voltage supply (for the device)
\perp ; \downarrow ; GND; 0 V	Ground (for the signals)
\perp ; \nearrow	Earth ground (housing)
K1; A; A+	Output signal channel 1
$\overline{K1}$; \overline{A} ; A-	Output signal channel 1 inverted
K2; B; B+	Output signal channel 2 (offset by 90° to channel 1)
$\overline{K2}$; \overline{B} ; B-	Output signal channel 2 (offset by 90° to channel 1) inverted
K0; C; R; R+	Zero pulse (reference signal)
$\overline{K0}$; \overline{C} ; \overline{R} ; R-	Zero pulse (reference signal) inverted
dnu	Do not use

Incremental encoders

Solid shaft $\varnothing 6$ mm with synchro flange
100...512 pulses per revolution

OG 6

Dimensions

