

Combination

Twin encoder with two electrically separated systems

Solid shaft with EURO flange B10

300...5000 pulses per revolution

POG 9 G



POG 9 G

Technical data - electrical ratings

Voltage supply	9...30 VDC 5 VDC \pm 5 %
Consumption w/o load	\leq 100 mA
Pulses per revolution	300...5000
Phase shift	90° \pm 20°
Duty cycle	40...60 %
Reference signal	Zero pulse, width 90°
Output frequency	\leq 120 kHz \leq 300 kHz (on request)
Output signals	K1, K2, K0 + inverted Error output (option EMS)
Output stages	HTL-P (power linedriver) TTL/RS422
Sensing method	Optical
Interference immunity	EN 61000-6-2
Emitted interference	EN 61000-6-3
Approvals	CE, UL approval / E256710

Features

- Twin encoder featuring two separate systems
- TTL output driver for cable length up to 500 m
- Very high resistance to shock
- EURO flange B10 / solid shaft \varnothing 11 mm

Optional

- Function control with EMS
(Enhanced Monitoring System)

Technical data - mechanical design

Size (flange)	\varnothing 115 mm
Shaft type	\varnothing 11 mm solid shaft
Admitted shaft load	\leq 250 N axial \leq 350 N radial
Flange	EURO flange B10
Protection DIN EN 60529	IP 56
Operating speed	\leq 12000 rpm (mechanical)
Operating torque typ.	2 Ncm
Rotor moment of inertia	200 gcm ²
Materials	Housing: aluminium die-cast Shaft: stainless steel
Operating temperature	-30...+100 °C -25...+100 °C (>3072 pulses per revolution)
Resistance	IEC 60068-2-6 Vibration 10 g, 10-2000 Hz IEC 60068-2-27 Shock 300 g, 1 ms
Corrosion protection	IEC 60068-2-52 Salt mist for ambient conditions C4 according to ISO 12944-2
Explosion protection	II 3 G Ex nA IIC T4 Gc (gas) II 3 D Ex tc IIIB T135°C Dc (dust)
Connection	2x terminal box
Weight approx.	2 kg

Combination

Twin encoder with two electrically separated systems

Solid shaft with EURO flange B10

300...5000 pulses per revolution

POG 9 G

Part number

POG9

	G	DN					/	DN				
--	---	----	--	--	--	--	---	----	--	--	--	--

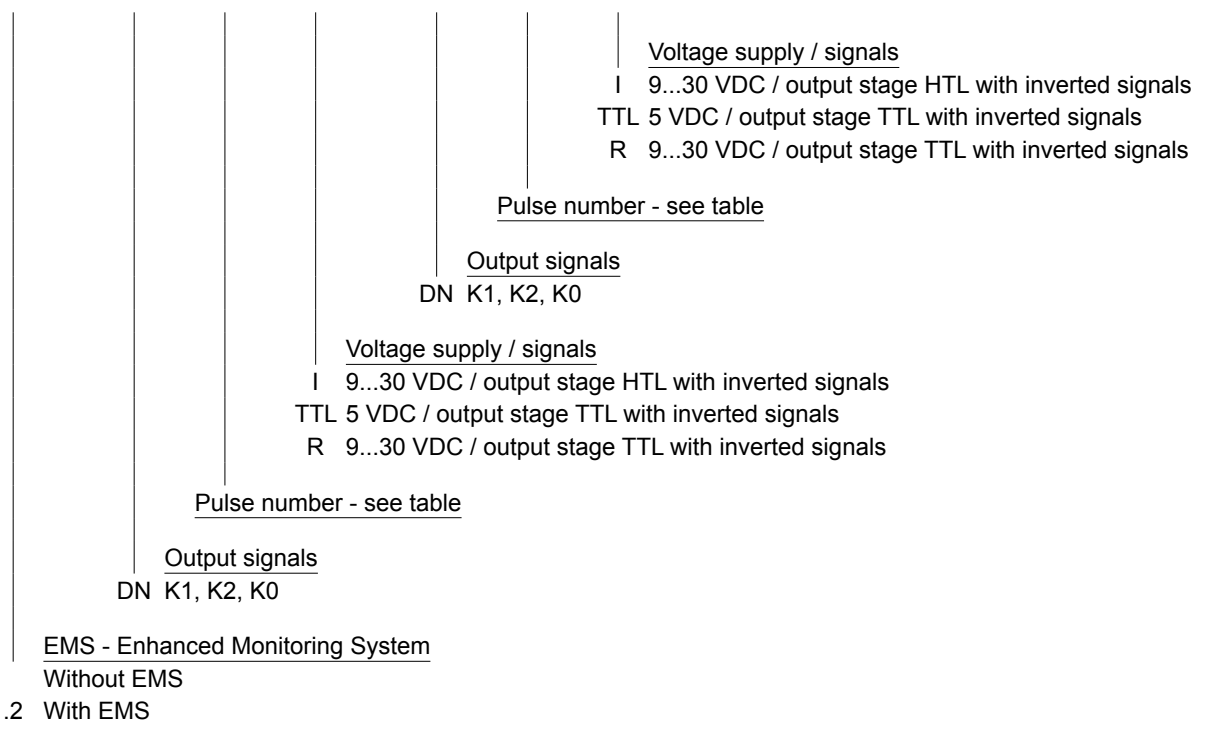

Pulse number

300	1000	2048	4096
500	1024	2500	5000
512	1200	3072	

Other pulse numbers on request.

Combination

Twin encoder with two electrically separated systems

Solid shaft with EURO flange B10

300...5000 pulses per revolution

POG 9 G

Output signals

At positive rotating direction

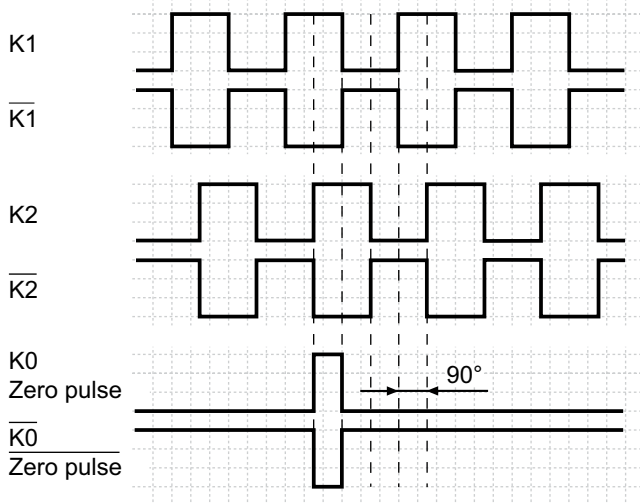

Terminal significance

+UB	Voltage supply (for the device)
⊥; ↓; GND; 0 V	Ground (for the signals)
⊥; ↘	Earth ground (housing)
K1; A; A+	Output signal channel 1
K1̄; Ā; A-	Output signal channel 1 inverted
K2; B; B+	Output signal channel 2 (offset by 90° to channel 1)
K2̄; B̄; B-	Output signal channel 2 (offset by 90° to channel 1) inverted
K0; C; R; R+	Zero pulse (reference signal)
K0̄; C̄; R̄; R-	Zero pulse (reference signal) inverted
Err; Err-	Error output (option EMS)
dnu	Do not use

Accessories

Connectors and cables

HEK 8	Sensor cable for encoders
-------	---------------------------

Mounting accessories

K 35	Spring washer coupling for solid shaft $\varnothing 6...12$ mm
K 50	Spring washer coupling for solid shaft $\varnothing 11...16$ mm
K 60	Spring washer coupling for solid shaft $\varnothing 11...22$ mm

Diagnostic accessories

11075858	Analyzer for encoders HENQ 1100
----------	---------------------------------

Terminal assignment

View A

Connecting terminal terminal box

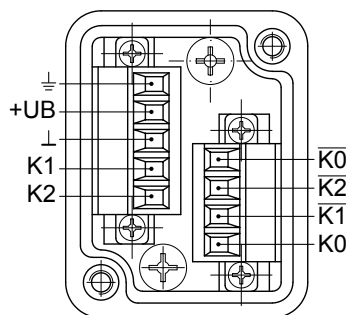

Option EMS: View A

Connecting terminal terminal box

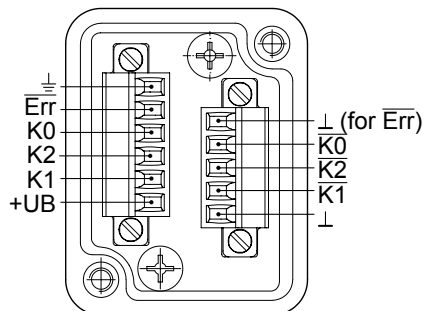

Option EMS: LED status / Error output

Flash light red*	Error of signal sequence, zero pulse or pulses (Error output = HIGH-LOW alternation)
Red	Overload output driver (Error output = LOW)
Flash light green	Device o.k., rotating (Error output = HIGH)
Green	Device o.k., stopped (Error output = HIGH)
No light	No voltage supply connection or wrong connection (Error output = LOW)

* Only at rotating device

Combination

Twin encoder with two electrically separated systems

Solid shaft with EURO flange B10

300...5000 pulses per revolution

POG 9 G

Dimensions

