

IWRM 30I9704/S14

Distanz messend

Distance measuring

Mesure de distances



10160781



Baumer

Baumer Electric AG · CH-8501 Frauenfeld
Phone +41 (0)52 728 1122 · Fax +41 (0)52 728 1144



Abmessungen Dimensions Dimensions

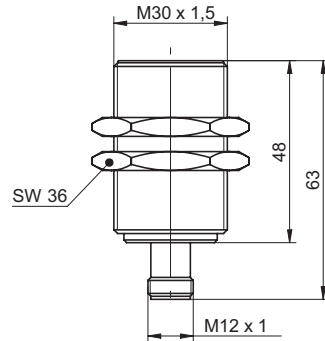

- Alle Masse in mm
- All dimensions in mm
- Toutes les dimensions en mm

Elektrischer Anschluss Connection diagram Schéma de raccordement

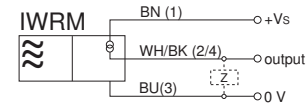

BN = Braun/brown/brun
WH = Weiss/white/blanc
BK = Schwarz/black/noir
BU = Blau/blue/bleu

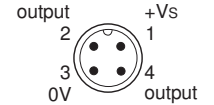

- Vor dem Anschliessen des Sensors die Anlage spannungsfrei schalten.
- Disconnect power before connecting the sensor.
- Mettre l'installation hors tension avant le raccordement du détecteur.

Empfohlene Montage für optimale Messergebnisse Recommended setup for optimal results Configuration recommandée pour des résultats optimaux

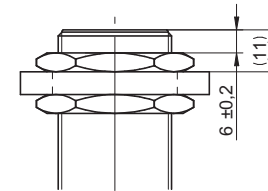

- Ein von der Vorschrift abweichender Einbau kann zu markanter Beeinflussung der Ausgangskennlinie führen.
- Failure to observe enclosed recommended mounting instructions will result in an undesired deviation from published output characteristic curve.
- Le non-respect des instructions de montage recommandées peut entraîner une déviation non conforme aux caractéristiques des courbes de sortie publiées.

Canada
Baumer Inc.
CA-Burlington, ON L7M 4B9
Phone +1 (1)905 335-8444

Italy
Baumer Italia S.r.l.
IT-20090 Assago, MI
Phone +39 (0)2 45 70 60 65

China
Baumer (China) Co., Ltd.
CN-201612 Shanghai
Phone +86 (0)21 6768 7095

Singapore
Baumer (Singapore) Pte. Ltd.
SG-339412 Singapore
Phone +65 6396 4131

Denmark
Baumer A/S
DK-8210 Aarhus V
Phone: +45 (0)8931 7611

Sweden
Baumer A/S
SE-56133 Huskvarna
Phone +46 (0)36 13 94 30

France
Baumer SAS
FR-74250 Fillinges
Phone +33 (0)450 392 466

Switzerland
Baumer Electric AG
CH-8501 Frauenfeld
Phone +41 (0)52 728 1313

Germany
Baumer GmbH
DE-61169 Friedberg
Phone +49 (0)6031 60 07 0

United Kingdom
Baumer Ltd.
GB-Watchfield, Swindon, SN6 8TZ
Phone +44 (0)1793 783 839

India
Baumer India Private Limited
IN-411058 Pune
Phone +91 20 66292400

USA
Baumer Ltd.
US-Southington, CT 06489
Phone +1 (1)860 621-2121

www.baumer.com/worldwide

Technische Daten

Technical data

Données techniques

Messdistanz Sd	Measuring distance Sd	Distance de mesure Sd	0...16 mm
Einbauart	Mounting type	Type de montage	Quasi- bündig/flush/noyé
Ausgangssignal	Output signal	Signal de sortie	4...20 mA
Betriebsspannungsbereich (UL-Class 2)	Voltage supply range (UL-Class 2)	Plage de tension (UL-Class 2)	15...30 VDC
Stromaufnahme max. (ohne Last)	Current consumption max. (no load)	Consommation max. (sans charge)	20 mA
Lastwiderstand @ +Vs min./+Vs max.	Load resistance @ +Vs min./+Vs max.	Résistance de charge @ +Vs min./+Vs max.	< 330 Ohm / <1000 Ohm
Kurzschlussfest	Short circuit protection	Protégé contre courts-circuits	ja/yes/oui
Verpolungsfest	Reverse polarity protection	Protégé contre inversion polarité	ja/yes/oui
Material (aktive Fläche)	Material (sensing face)	Matériau (face active)	PBT
Gehäusematerial	Housing material	Matériau du boîtier	Brass nickel plated
Arbeitstemperatur	Operating temperature	Température de fonctionnement	-10...+70°C
Schutzklasse	Protection class	Classe de protection	IP67

