

# Incremental encoders

## Solid shaft with synchro flange

### 64...2048 pulses per revolution

#### BRIV 58S - EcoMag



BRIV 58S with synchro flange

#### Features

- Encoder with solid shaft  $\varnothing 6$  mm
- Magnetic sensing method
- Max. 2048 pulses per revolution
- High resistance to shock and vibrations
- High limit frequency
- Synchro flange

#### Technical data - electrical ratings

Voltage supply	5 VDC $\pm 10$ % 10...30 VDC
Consumption typ.	30 mA (5 VDC, w/o load) 15 mA (24 VDC, w/o load)
Pulses per revolution	64...2048
Reference signal	Zero pulse, width 90°
Sensing method	Magnetic
Output frequency	$\leq 320$ kHz
Output signals	A 90° B, N + inverted
Output stages	Antivalent Push-pull short-circuit proof
Interference immunity	DIN EN 61000-6-2
Emitted interference	DIN EN 61000-6-3
Approval	UL approval / E217823

#### Technical data - mechanical design

Size (flange)	$\varnothing 58$ mm
Shaft type	$\varnothing 6$ mm solid shaft (synchro flange)
Admitted shaft load	$\leq 40$ N axial $\leq 50$ N radial
Flange	Synchro flange
Protection DIN EN 60529	IP 42, IP 65
Operating speed	$\leq 12000$ rpm (IP 42) $\leq 6000$ rpm (IP 65)
Operating torque typ.	0.0175 Nm (IP 42) 0.047 Nm (IP 65)
Materials	Housing: aluminium Flange: aluminium
Operating temperature	-20...+85 °C
Relative humidity	95 % non-condensing
Resistance	DIN EN 60068-2-6 Vibration 30 g, 10-2000 Hz DIN EN 60068-2-27 Shock 500 g, 6 ms
Connection	Connector M12, 5-pin Connector M12, 8-pin Connector M23, 12-pin Cable 2 m
Weight approx.	150 g

# Incremental encoders

## Solid shaft with synchro flange

### 64...2048 pulses per revolution

## BRIV 58S - EcoMag

### Part number

BRIV 58S16

--	--	--	--

					<u>Connection</u>
				5	Cable 2 m, radial
				A	Connector M23, radial
				N	Connector M12, radial
					<u>Solid shaft</u>
				06	ø6 mm, IP 42
				C6	ø6 mm, IP 65
					<u>Pulse number - see table</u>
					<u>Voltage supply / signals</u>
					05A 5 VDC / antivalent (TTL compatible)
					24K 10...30 VDC / push-pull short-circuit proof

### Pulse number

64	512	1024	2000
360	1000	1800	2048

Other pulse numbers on request.

### Trigger level

Outputs 05A	Complementary Linedriver RS422
Output level High	>2,4 V (I = -20 mA)
Output level Low	<0,4 V (I = 20 mA)
Load High	<20 mA
Load Low	<20 mA
Outputs 24K	Push-pull short-circuit protection
Output level High	>+Vs - 3,7 V (I = -30 mA)
Output level Low	<2,5 V (I = 30 mA)
Load High	<30 mA
Load Low	<30 mA

### Accessories

#### Connectors and cables

10107687	Female connector M23, 12-pin, straight, without cable
10130367	Female connector M23, 12-pin, straight, 2 m cable
10118532	Female connector M23, 12-pin, straight, 5 m cable
10146775	Female connector M12, 8-pin, straight, without cable
10127844	Female connector M12, 8-pin, straight, shielded, 2 m cable
10153968	Female connector M12, 5-pin, straight, without cable
11046264	Female connector M12, 5-pin, straight, shielded, 2 m cable
11046266	Female connector M12, 5-pin, straight, shielded, 5 m cable

#### Mounting accessories

10252773	Clamp set ø15 mm
----------	------------------

# Incremental encoders

## Solid shaft with synchro flange

### 64...2048 pulses per revolution

#### BRIV 58S - EcoMag

#### Terminal assignment

##### Cable

for connection reference -5

05A		24K	
Core colour	Signals	Core colour	Signals
brown	+Vs	brown	+Vs
green	CHA	green	CHA
red	CHA inv.	–	–
yellow	CHB	yellow	CHB
blue	CHB inv.	–	–
pink	CHN	pink	CHN
grey	CHN inv.	–	–
white	0 V	white	0 V
Cable data: 8 x 0.14 mm <sup>2</sup>		5 x 0.14 mm <sup>2</sup>	
Screen: connected to housing			

##### Connector M23, 12-pin

for connection reference -A

05A		24K	
Pin	Signals	Pin	Signals
1	CHA inv.	1	n.c.
2	+Vs	2	+Vs
3	CHN	3	CHN
4	CHN inv.	4	n.c.
5	CHB	5	CHB
6	CHB inv.	6	n.c.
7	n.c.	7	n.c.
8	CHA	8	CHA
9	Housing	9	Housing
10	0 V	10	0 V
11 - 12	n.c.	11 - 12	n.c.

#### Output signals

Counter clockwise rotating direction when looking at the flange.

##### 05A

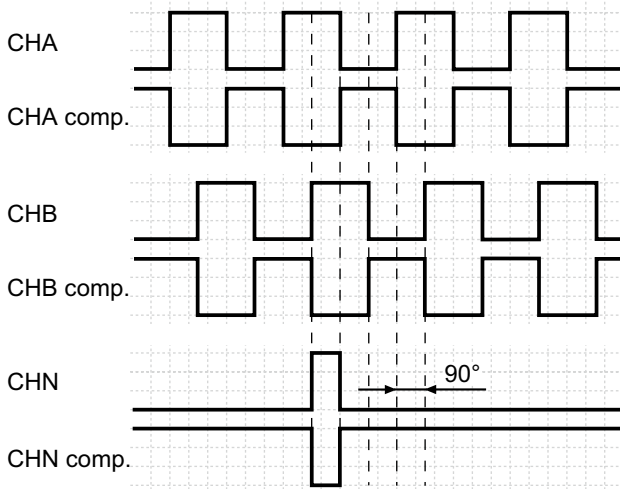

Counter clockwise rotating direction when looking at the flange.

##### 24K

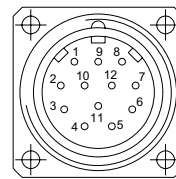
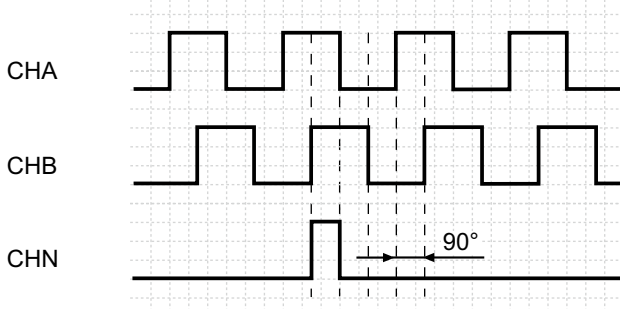

##### Connector M12, 8-pin / 5-pin

for connection reference -N

##### 05A

Pin	Core colour*	Signals
1	white	0 V
2	brown	+Vs
3	green	CHA
4	yellow	CHB
5	grey	CHN inv.
6	pink	CHN
7	blue	CHB inv.
8	red	CHA inv.

##### 24K

Pin	Core colour*	Signals
1	brown	+Vs
2	white	0 V
3	blue	CHA
4	black	CHB
5	grey	CHN

\*valid for the assembled mating connectors (see access.)

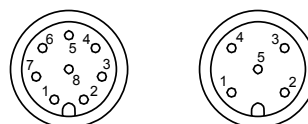

# Incremental encoders

## Solid shaft with synchro flange

### 64...2048 pulses per revolution

BRIV 58S - EcoMag

#### Dimensions

BRIV 58S, cable radial

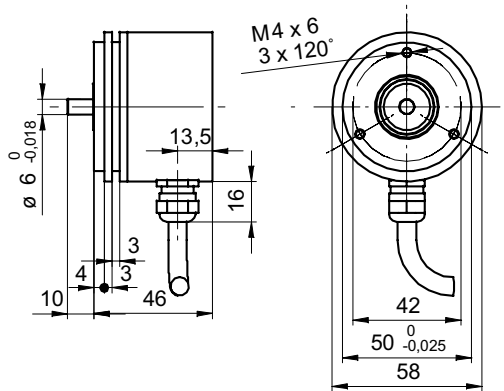

BRIV 58S, connector output M23 radial

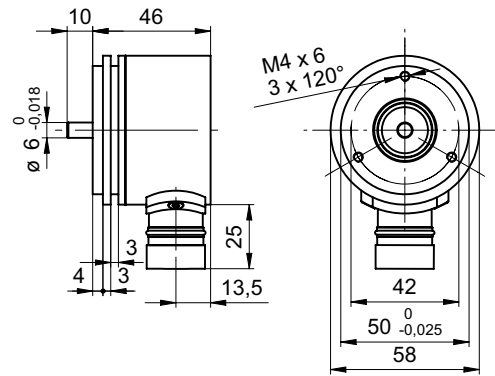

BRIV 58S, connector output M12 radial

