

Incremental encoders

Solid shaft with EURO flange B10

500...5000 pulses per revolution

POG 86E



POG 86E

Technical data - electrical ratings

Voltage supply	9...30 VDC 5 VDC \pm 5 %
Consumption w/o load	\leq 100 mA
Pulses per revolution	500...5000
Phase shift	90° \pm 20°
Duty cycle	45...55 % (40...60 % >3072 pulses per revolution)
Reference signal	Zero pulse, width 90°
Sensing method	Optical
Output frequency	\leq 170 kHz \leq 300 kHz (on request)
Output signals	K1, K2, K0 + inverted Error output (option EMS)
Output stages	HTL-P (power linedriver) TTL/RS422
Interference immunity	EN 61000-6-2
Emitted interference	EN 61000-6-3
Approvals	CE, UL/ CSA approval / E256710

Features

- Robust, compact housing
- Two bearings with large distance, one at each end
- High shaft load up to 350 N
- Shock resistant up to 300 g
- Highest operating speed 12000 rpm
- TTL output driver for cable length up to 550 m
- Terminal box, turn by 180°

Optional

- Function control with EMS
(Enhanced Monitoring System)

Technical data - mechanical design

Size (flange)	\varnothing 115 mm
Shaft type	\varnothing 11 mm solid shaft
Admitted shaft load	\leq 250 N axial \leq 350 N radial
Flange	EURO flange B10
Protection DIN EN 60529	IP 56
Operating speed	\leq 12000 rpm (mechanical)
Operating torque typ.	2 Ncm
Rotor moment of inertia	200 gcm ²
Materials	Housing: aluminium Shaft: stainless steel
Operating temperature	-40...+100 °C -25...+100 °C (>3072 pulses per revolution)
Resistance	IEC 60068-2-6 Vibration 10 g, 10-2000 Hz IEC 60068-2-27 Shock 300 g, 1 ms
Corrosion protection	Option: IEC 60068-2-52 Salt mist for ambient conditions C4 according to ISO 12944-2
Explosion protection	II 3 G Ex nA IIC T4 Gc (gas) II 3 D Ex tc IIIB T135°C Dc (dust)
Connection	Terminal box
Weight approx.	1.4 kg

Incremental encoders

Solid shaft with EURO flange B10

500...5000 pulses per revolution

POG 86E

Output signals

At positive rotating direction

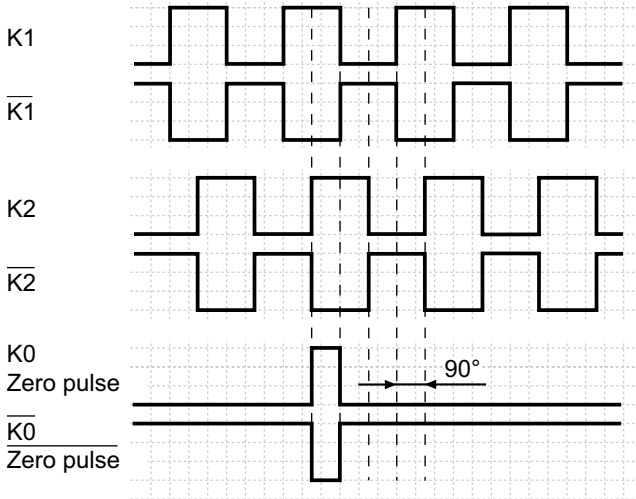

Terminal significance

+UB	Voltage supply (for the device)
⊥; ↓; GND; 0 V	Ground (for the signals)
⊥; ↘	Earth ground (housing)
K1; A; A+	Output signal channel 1
K1̄; Ā; A-	Output signal channel 1 inverted
K2; B; B+	Output signal channel 2 (offset by 90° to channel 1)
K2̄; B̄; B-	Output signal channel 2 (offset by 90° to channel 1) inverted
K0; C; R; R+	Zero pulse (reference signal)
K0̄; C̄; R̄; R-	Zero pulse (reference signal) inverted
Err; Err-	Error output (option EMS)
dnu	Do not use

Terminal assignment

View A

Connecting terminal terminal box

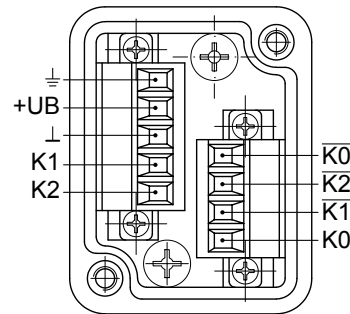

Option EMS: View A

Connecting terminal terminal box

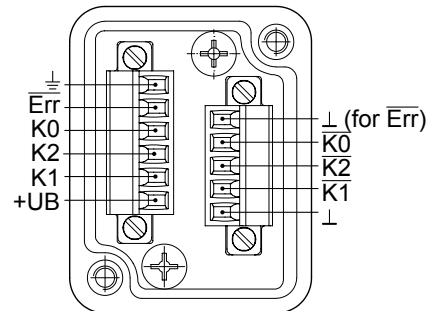

Option EMS: LED status / Error output

Flash light red*	Error of signal sequence, zero pulse or pulses (Error output = HIGH-LOW alternation)
Red	Overload output driver (Error output = LOW)
Flash light green	Device o.k., rotating (Error output = HIGH)
Green	Device o.k., stopped (Error output = HIGH)
No light	No voltage supply connection or wrong connection (Error output = LOW)

* Only at rotating device

Incremental encoders

Solid shaft with EURO flange B10
500...5000 pulses per revolution

POG 86E

Dimensions

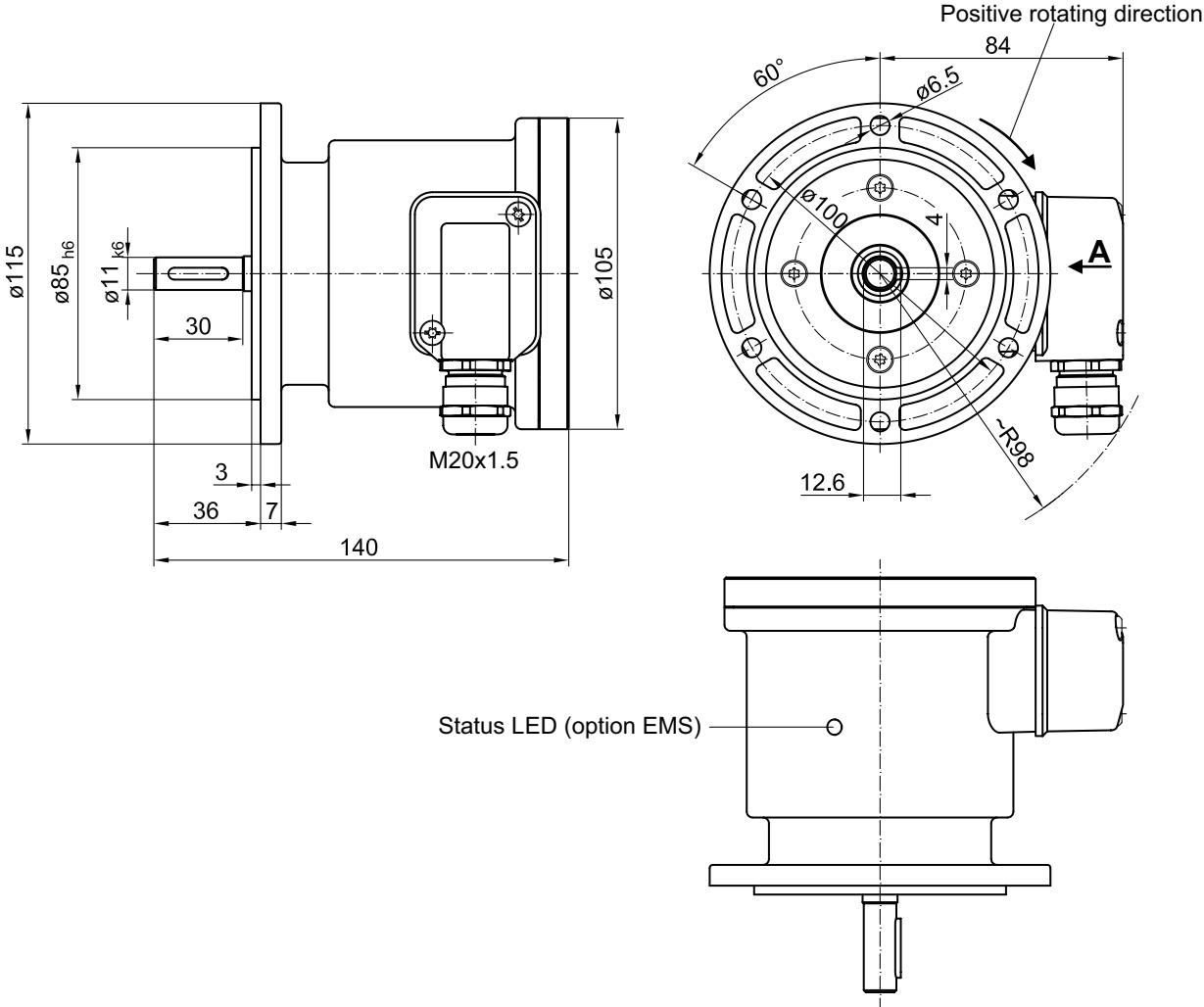

Subject to modification in technic and design. Errors and omissions excepted.