

## USK-M | metric thread

## Connectors

Plastic connector, straight, metric outer thread, incl. ferrule and sealing

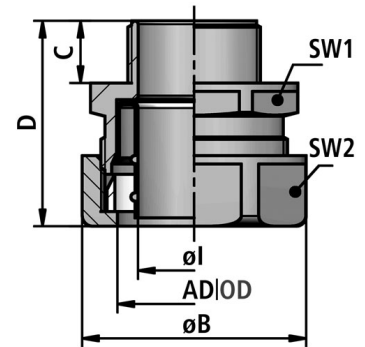

Temperature: -10°C ... +110°C

Material: PP plastics

Protection class [acc. to EN 60529]: IP4



FLEXA No.	OD [mm]	Colour	Thread type	ø I [mm]	ø B [mm]	C [mm]	D [mm]	WS1 [mm]	WS2 [mm]	Weight [kg/100]	PU [pcs.]
15020330010	10,0	Grey	M 10 x 1,0	6,0	20,0	10,0	40,0	16	18	0,340	50
15020330012	14,0	Grey	M12 x 1,5	8,0	25,0	12,0	43,0	21	23	0,660	50
15020330016	17,0	Grey	M16 x 1,5	11,0	30,0	12,0	43,0	24	27	0,880	50
15020330020	21,0	Grey	M20 x 1,5	15,0	35,0	13,0	44,0	29	32	1,220	50
15020330025	27,0	Grey	M25 x 1,5	20,0	44,0	13,0	50,0	36	40	2,400	25
15020330032	36,0	Grey	M32 x 1,5	27,0	54,0	15,0	51,0	45	49	3,120	25
15020330040	45,0	Grey	M40 x 1,5	35,0	63,0	15,0	51,0	54	58	3,920	25
15020330050	56,0	Grey	M50 x 1,5	44,5	77,0	16,0	58,0	66	70	6,200	10
15020330063	56,0	Grey	M63 x 1,5	44,5	77,0	16,0	58,0	66	70	8,800	10
15020730010	10,0	Grey	M 10 x 1,0	6,0	20,0	10,0	40,0	16	18	0,340	10
15020730012	14,0	Grey	M12 x 1,5	8,0	25,0	12,0	43,0	21	23	0,660	10
15020730016	17,0	Grey	M16 x 1,5	11,0	30,0	12,0	43,0	24	27	0,880	10
15020730020	21,0	Grey	M20 x 1,5	15,0	35,0	13,0	44,0	29	32	1,220	10
15020730025	27,0	Grey	M25 x 1,5	20,0	44,0	13,0	50,0	36	40	2,400	10
15020730032	36,0	Grey	M32 x 1,5	27,0	54,0	15,0	51,0	45	49	3,120	2
15020730040	45,0	Grey	M40 x 1,5	35,0	63,0	15,0	51,0	54	58	3,920	2
15020730050	56,0	Grey	M50 x 1,5	44,5	77,0	16,0	58,0	66	70	6,200	2
15020730063	56,0	Grey	M63 x 1,5	44,5	77,0	16,0	58,0	66	70	8,800	2

Recommendations for any areas of applications, products, or product combinations are issued to the best of FLEXA's knowledge and experience. The user is requested to check applicability of FLEXA products to specific applications and purposes prior to the use of the particular products. All documentation, illustrations, and charts published are subject to copyright and must not be copied, changed, used, or modified. Technical drawings, certificates, authorizations, and results by the FLEXA lab will be provided upon request. FLEXA will not be held liable for typographical or other errors and incorrect drawings. Technical modifications are subject to change without prior notice.