

DN6/DN9

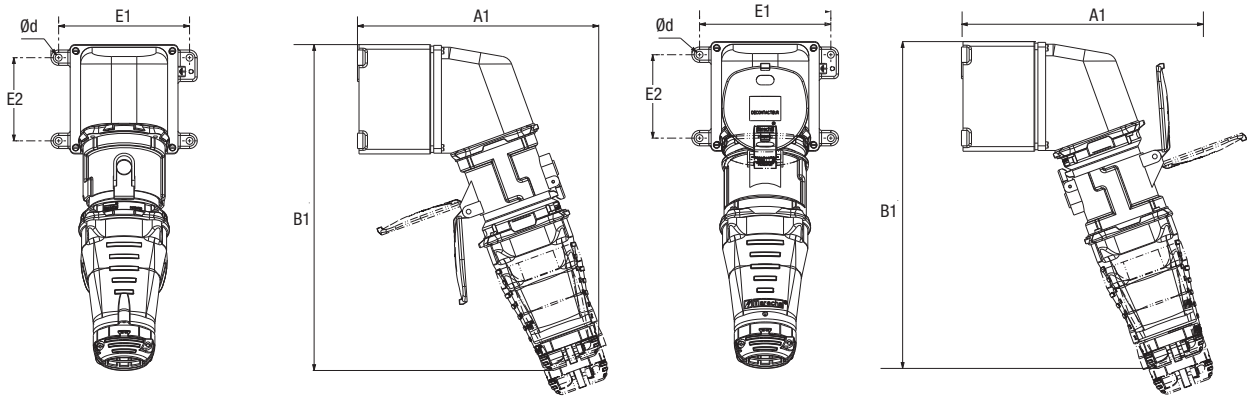

|     | A2  | B2  | E1  | E2  | $\varnothing d^*$ |
|-----|-----|-----|-----|-----|-------------------|
| DN1 | 203 | 267 | 110 | 70  | 6,5               |
| DN3 | 239 | 320 | 145 | 97  | 8,5               |
| DN6 | 313 | 423 | 190 | 108 | 9                 |

DN8/DN1/DN3/DN6

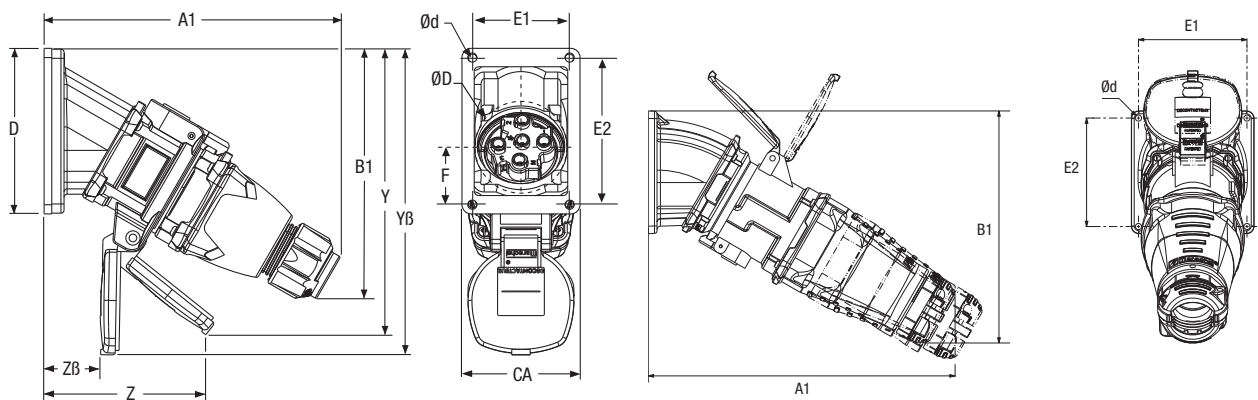

|     | A1  | b1  | D   | E1  | E2  | $\varnothing d^*$ |
|-----|-----|-----|-----|-----|-----|-------------------|
| DN8 | 189 | 168 | 108 | 63  | 95  | 5,5               |
| DN1 | 104 | 178 | 107 | 63  | 95  | 5,5               |
| DN3 | 242 | 220 | 136 | 87  | 122 | 6,5               |
| DN6 | 350 | 265 | 140 | 124 | 124 | 7                 |

\* $\varnothing d$  : maximum drilling diameter.